

Normal safety valve with spring loading. (AN)

Thread connection
Flange connection

Model 295
Model 296



EN

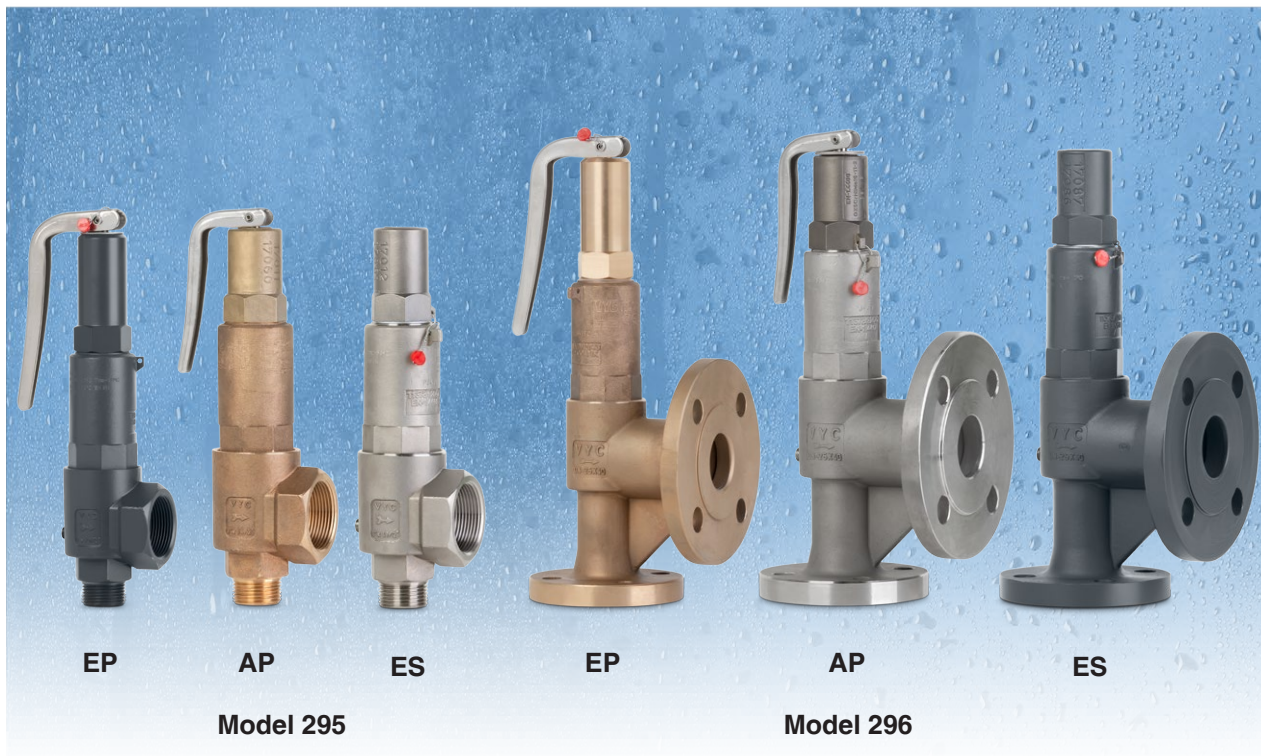

EP

AP

ES

EP

AP

ES

Model 295

Model 296

The valve works as an automatic pressure releasing regulator activated by the static pressure existing at the entrance to the valve and is characterized by its ability to open, at the first proportional to the pressure increase, and after instantly and totally.

Design in accordance with "International Standard ISO 4126-1 Safety Valves".

In accordance with the requirements of the pressure equipment directive 2014/68/EU.

EC valve verification certified by: TÜV Internacional Grupo TÜV Rheinland, S.L. EC 0035.

Type (Module D) EC examination report nº 33530455 certified by: TÜV Internacional Grupo TÜV Rheinland, S.L.

In compliance with the ATEX 2014/34/EU directive "Protective equipment and systems for use in potentially explosive atmospheres".

Other authorisations: ISCIR, ITI, NASTHOL, EAC, ...etc.

Specifications

- Model AP open cap with lever.
- Model ES closed cap without lever.
- Model EP closed cap with lever.
- 90° angular flow.
- Activated by direct action helicoid spring.
- Simplicity of construction ensuring minimum maintenance.
- Materials carefully selected for their resistance to corrosion.
- Internal body designed to offer favourable flow profile.
- Seat and sealing disk balanced, making them extremely tightness, even exceeding EN 12266-1.
- Great discharge capacity.
- Deflector nut designed to make easier the steam expansion, a sudden opening and to measure the blowdown of any fluid.
- Guarantees absolute opening and closing precision.
- Equipped with draining screws for removing condensation.
- Orientation of the lever by rotation.
- All the valves are supplied sealed at the set pressure requested, simulating operational conditions, and are vigorously tested.
- All components are numbered, registered and checked. If requested in advance, material, casting, test and efficiency certificates will be enclosed with the valve, and the instruction manual, in accordance with P.E.D. 2014/68/EU.

IMPORTANT

1.- Silicone's rubber, Fluorelastomer (Vitón) seals, PTFE (Teflón)... etc., achieving leakage levels less than:

$$0,3 \times 10^{-3} \frac{\text{Pa cm}^3}{\text{sec.}}$$

The ranges of application allow certain flexibility although we recommend limiting them to:

RANGE OF APPLICATIONS OF THE SEALS					
FLUID	PRESION DE DISPARO EN bar				
	0,2	1,5	3,5	4,0	8,0
Saturated steam	S	V			T
Liquids and gases	S		V		T
SEALS	TEMPERATURE IN °C				
	ACCORDING TO MANUFACTURERS		RECOMMENDEEN BY VYC		
	MINIMUM	MAXIMUM	MINIMUM	MAXIMUM	
Silicone's rubber	S	-60	+200	-50	+115
Fluorelastomer (Vitón)	V	-40	+250	-30	+150
PTFE (Teflon)	T	-265	+260	-80	+230 (1)

(1) For temperatures exceeding 230°C apply metallic seal only.

Depending on demand:

- Buna-nitrils seals, Butyl, Natural rubber, E.P.D.M., Chlorosulphonate polyethylene (Hypalon), Neoprene, etc.
- Seal metal by metal.
- Electrical contact indicating open/closed.
- Other connections.
- Possibility of manufacture in other types of material, for special operating conditions (high temperatures, fluids, etc.).
- Totally free of oil and grease, to work with oxygen, avoiding possible fire risks (UV-Oxygen-VBG62).

Nº. PIECE	PIECE	MATERIAL		
		BRONZE	CARBON STEEL	STAINLESS STEEL
1, 25	Body	Bronze (EN-CC491K)	Carbon steel (EN-1.0619)	Stainless steel (EN-1.4408)
2	Bell	Bronze (EN-CC491K)	Carbon steel (EN-1.0619)	Stainless steel (EN-1.4408)
3	Lever	Stainless steel (EN-1.4301)	Stainless steel (EN-1.4301)	Stainless steel (EN-1.4301)
4	Cap	Brass (EN-CW617N) (1)	Carbon steel (EN-1.1191) (2)	Stainless steel (EN-1.4305) (3)
5	Hollow screw	Brass (EN-CW617N)	Stainless steel (EN-1.4305)	Stainless steel (EN-1.4305)
6	Hollow screw nut	Brass (EN-CW617N)	Stainless steel (EN-1.4305)	Stainless steel (EN-1.4305)
7, 24, 31	Rod	Stainless steel (EN-1.4401)	Stainless steel (EN-1.4401)	Stainless steel (EN-1.4401)
8	Ring (5)	Stainless steel (EN-1.4301)	Stainless steel (EN-1.4301)	Stainless steel (EN-1.4301)
9	Lead	Brass (EN-CW617N)	Stainless steel (EN-1.4401)	Stainless steel (EN-1.4401)
10	Plug	Brass (EN-CW617N)	Stainless steel (EN-1.4401)	Stainless steel (EN-1.4401)
11	Deflector	Brass (EN-CW617N)	Stainless steel (EN-1.4401)	Stainless steel (EN-1.4401)
12	Stud	Stainless steel (EN-1.4401)	Stainless steel (EN-1.4401)	Stainless steel (EN-1.4401)
13	Sealing nut	Brass (EN-CW617N)	Stainless steel (EN-1.4401)	Stainless steel (EN-1.4401)
14	Cap	Brass (EN-CW617N)	Stainless steel (EN-1.4401)	Stainless steel (EN-1.4401)
15	Sealing wire	Sealing wire	Sealing wire	Sealing wire
16	Safety ring (4)	Stainless steel (EN-1.4310)	Stainless steel (EN-1.4310)	Stainless steel (EN-1.4310)
17	Seal	Plastic	Plastic	Plastic
18	Sealing disk	PTFE (Teflón)	PTFE (Teflón)	PTFE (Teflón)
		Silicone's rubber	Silicone's rubber	Silicone's rubber
		Fluorelastomer (Vitón)	Fluorelastomer (Vitón)	Fluorelastomer (Vitón)
19	Spring press	Brass (EN-CW617N)	Stainless steel (EN-1.4301)	Stainless steel (EN-1.4301)
20	Spring	Stainless steel (EN-1.4310)	Stainless steel (EN-1.4310)	Stainless steel (EN-1.4310)
21	Clip	Stainless steel (EN-1.4310)	Stainless steel (EN-1.4310)	Stainless steel (EN-1.4310)
22	Joint	PTFE (Teflón)	PTFE (Teflón)	PTFE (Teflón)
23	Washer	PTFE (Teflón)	PTFE (Teflón)	PTFE (Teflón)
26	Piston spring	Stainless steel (EN-1.4310)	Stainless steel (EN-1.4310)	Stainless steel (EN-1.4310)
27	Piston	Brass (EN-CW617)	Stainless steel (EN-1.4305)	Stainless steel (EN-1.4305)
28	Piston base	Brass (EN-CW617)	Stainless steel (EN-1.4305)	Stainless steel (EN-1.4305)
29	Separator	Stainless steel (EN-1.4301)	Stainless steel (EN-1.4301)	Stainless steel (EN-1.4301)
30	O-ring	Fluorelastomer (Vitón)	Fluorelastomer (Vitón)	Fluorelastomer (Vitón)
	R1 x R2	1/2" x 1" to 1 1/4" x 2"		
	DN1 x DN2	15 x 25 to 32 x 50		
	PN	PN-40		
OPERATING CONDITIONS	PRESSION IN bar	25	25	25
	MAX. TEMP. IN °C	225	250	250
	MIN. TEMP. IN °C	-60	-10	-60

(1) From R. 1" x 1 1/2" / DN-25 x 40 in Bronze (EN-CC754S-GM). EP version always in EN - CW617N

(2) From R. 1" x 1 1/2" / DN-25 x 40 in Carbon steel (EN-1.0619). EP version always in EN - 1.1191

(3) From R. 1" x 1 1/2" / DN-25 x 40 in Stainless steel (EN-1.4408). EP version always in EN - 1.4305

(4) From R. 1" x 1 1/2" / DN-25 x 40.

(5) Stainless steel (EN-1.4568) for R. 1/2" x 1" / DN-15 x 25.

Stainless steel (EN-1.4310) for R. 3/4" x 1 1/4" / DN-20 x 32.

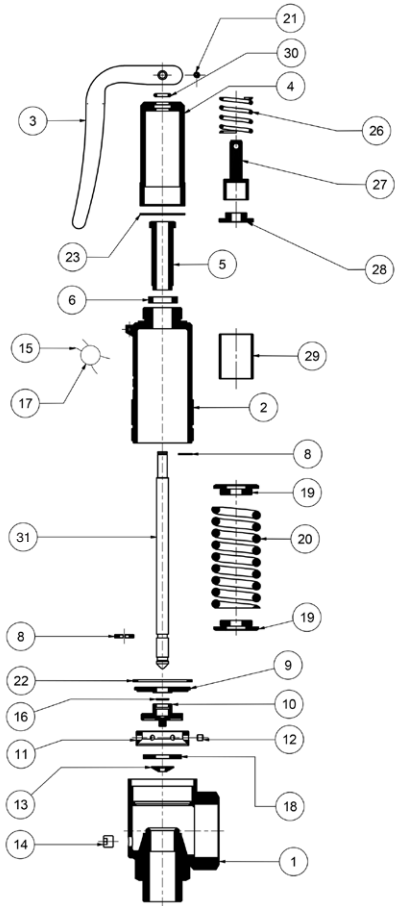

EP

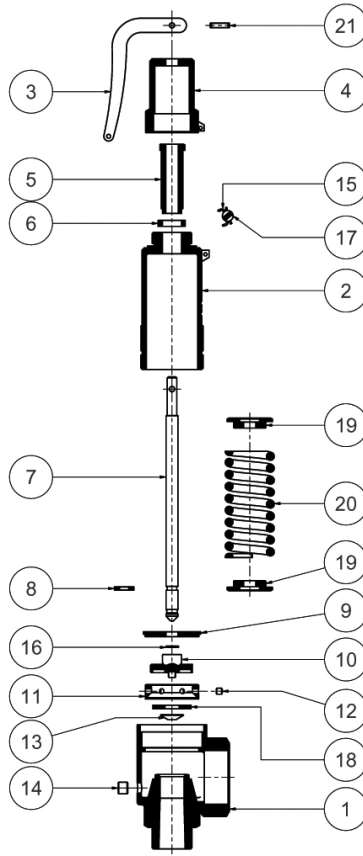

AP

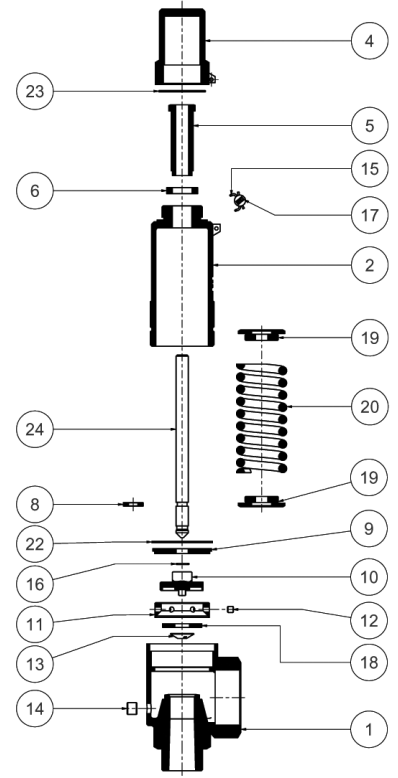

ES

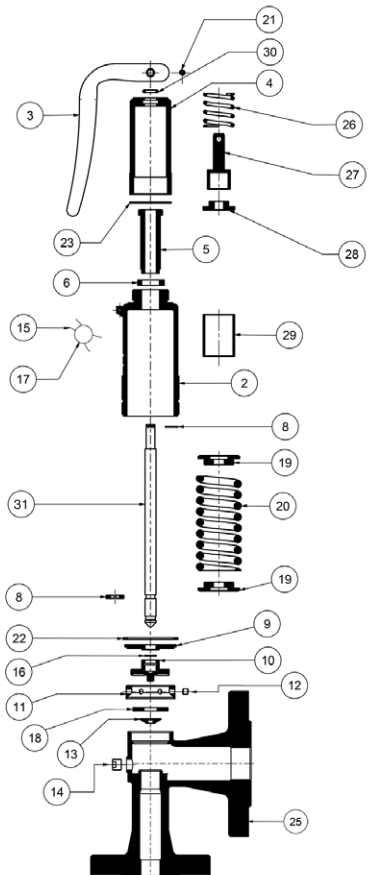

EP

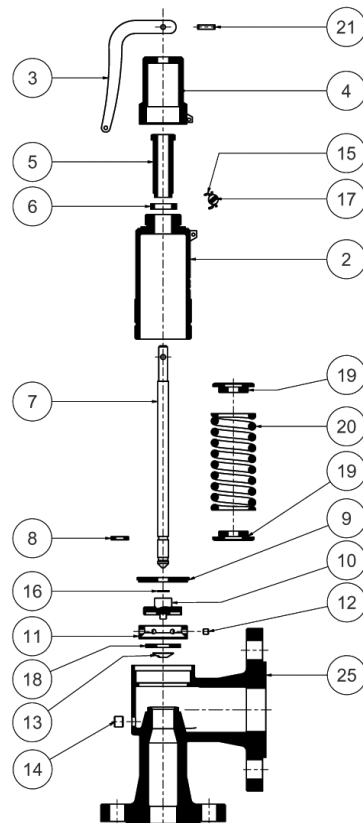

AP

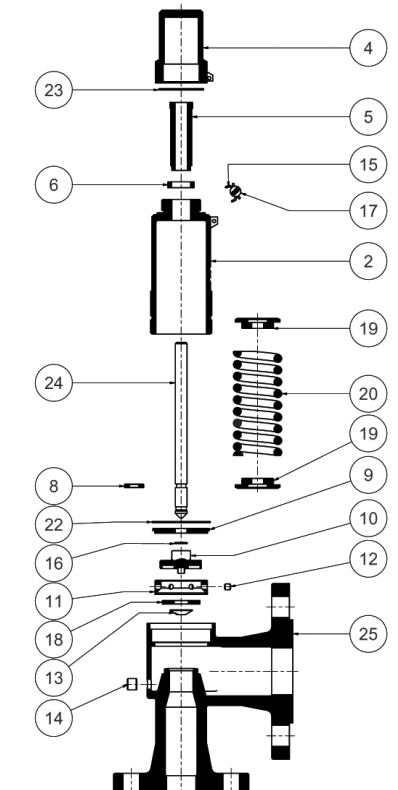

ES

Model 295

Model 296

DISASSEMBLY AND ASSEMBLY

1 – Disassembly

To replace the spring (20), or clean any of the internal components of the valve, proceed in the following manner:

- A – Withdraw the clip (21), using a punching tool, and lift the lever (3).
- B – Unscrew the cap (4) and remove.
- C – Holding the rod (7) (24) steady, loosen the hollow screw nut (6), until the constructive limit, and the hollow screw (5) until you note a releasing of the spring (20).
- D – Unscrew the bell (2) holding the rod (7) (24) and the body (1) (25) steady.
- E – Lift the bell (2) and you will have access to all the components.

2 – Assembly

- A – Enter the bell (2) and the joint (22) through the upper part of the rod (7) (24).
- B – Turn the bell (2) holding the rod (7) (24) and the body (1) (25) steady.
- C – Replace the hollow screw (5) with the hollow screw nut (6).
- D – Adjust the set pressure with the hollow screw (5) and fix the adjustment position with the hollow screw nut (6).
- E – Change the washer (23) and lightly tighten the cap (4).
- F – Place the lever (3) and fix it with the clip (21).

ADJUSTING THE SET PRESSURE

- A – Proceed according to DISASSEMBLY A, B, C.
- B – Proceed according to ASSEMBLY D, E, F.

ADJUSTEMENT OF THE BLOWDOWN

- A – Slack the stud (12).
- B – Twist or untwist the deflector (11) according the difference in the wished locking pressure (blowdown).
- C – Fix the deflector position screwing the stud (12).

WARNING

In case to do the change of the sealing disc (18) make sure that the surface of this as well as the one of the seat into the body (1) (25) the correctly rectified and free of impurities.

SET PRESSURES AND REGULATING RANGES						
		R ₁ x R ₂ DN ₁ x DN ₂	1/2" x 1" 15 x 25	3/4" x 1 1/4" 20 x 32	1" x 1 1/2" 25 x 40	1 1/4" x 2" 32 x 50
SET PRESSURES IN bar	MAXIMUM (LIQUIDS AND GASES)		25	25	25	25
	MAXIMUM (SATURATED STEAM)		25	25	25	25
	MINIMUM	STEAM AND GASES	0,5	0,5	0,5	0,5
LIQUIDS (1)		0,2	0,2	0,2	0,2	
SPRING REGULATION RANGE IN bar	0,20 to 0,70	CODE	56341	56348	56356	56364
	0,50 to 1,60	CODE	56342	56349	56357	56365
	1,40 to 3,50	CODE	56343	56350	56358	56366
	3,00 to 5,50	CODE	56344	56351	56359	56367
	5,00 to 10,00	CODE	56345	56352	56360	56368
	9,00 to 15,00	CODE	56346	56353	56361	56369
	14,00 to 20,00	CODE		56354	56362	56370
	19,00 to 25,00	CODE	56347	56355	56363	56371

(1) For set pressures less than 0,5 bar previous consult with our technical department.

RECOMMENDED RANGES OF APPLICATION				
MODEL		AP	ES	EP
FLUID	SATURATED STEAM	*		*
	GASES	* (1)	*	*
	LIQUIDS	* (1)	*	*

(1) With noxious or expensive fluids apply only ES or EP model.

If external backpressure exists, the AP model cannot be used.

With external constant backpressure, the spring is adjusted deducting the backpressure from the set pressure.

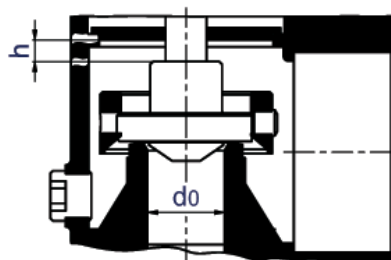

R1 x R2 DN1 x DN2		1/2" x 1" 15 x 25						3/4" x 1 1/4" 20 x 32						1" x 1 1/2" 25 x 40						1 1/4" x 2" 32 x 50							
MODEL		295 AP	295 ES	295 EP	296 AP	296 ES	296 EP	295 AP	295 ES	295 EP	296 AP	296 ES	296 EP	295 AP	295 ES	295 EP	296 AP	296 ES	296 EP	295 AP	295 ES	295 EP	296 AP	296 ES	296 EP		
d ₀		15						15						20						28							
$A_0 = \frac{\pi \cdot d_0^2}{4}$		176,7						176,7						314,2						615,8							
H		161	150	198	-	-	-	216	204	249	-	-	-	271	255	296	-	-	-	353	335	382	-	-	-		
H ₁		-	-	-	213	202	250	-	-	-	262	250	295	-	-	-	316	300	341	-	-	-	393	376	422		
h ₁		48	34	89	48	34	89	56	41	96	56	41	96	74	55	107	74	55	107	93	73	132	93	73	132		
L ₁		34						41						48						61							
L ₂		39						49						60						70							
L ₃		80						85						95						100							
L ₄		90						95						105						110							
R		1/8"						1/8"						1/8"						1/8"							
CONNECTIONS		Whitworth cylindrical Male x Female thread ISO 228/1 1978 (DIN-259)																									
INTAKE FLANGE	EN 1092-1 EN 1092-3 PN-25/40	D ₁		95						105						115						140					
		K ₁		65						75						85						100					
		l ₁		14						14						14						18					
		b ₁		16						18 (16)*						18						18					
		DRILLS No.		4						4						4						4					
ESCAPE FLANGE	EN 1092-1 EN 1092-3 PN-10/16	D ₂		115						140						150						165					
		K ₂		85						100						110 (3)						125					
		l ₂		14						18						18						18					
		b ₂		18 (12)*						18 (14)*						18 (14)*						18 (16)*					
		DRILLS No.		4						4						4						4					
WEIGHT IN Kgs.	BRONZE		0,62	0,59	0,79	2,89	2,86	3,45	1,35	1,32	1,47	4,90	4,87	4,97	2,68	2,57	2,87	6,52	6,41	6,97	5,15	4,86	5,44	10,72	10,43	10,99	
	CARBON STEEL		0,64	0,61	0,74	2,73	2,70	3,42	1,27	1,24	1,36	4,46	4,43	4,92	2,50	2,39	2,66	6,34	6,23	6,88	4,81	4,52	5,05	9,83	9,54	10,81	
	STAINLESS STEEL		0,65	0,62	0,75	2,67	2,64	3,43	1,30	1,27	1,39	4,57	4,54	4,94	2,55	2,44	2,70	6,39	6,28	6,91	4,89	4,60	5,12	10,06	9,77	10,85	
CODE	BRONZE		2002-295.60211	2002-295.60211	2002-295.60213	2002-295.60211	2002-295.60212	2002-295.60213	2002-295.63411	2002-295.63412	2002-295.63413	2002-295.63411	2002-295.63412	2002-295.63413	2002-295.61011	2002-295.61012	2002-295.61013	2002-295.61011	2002-295.61012	2002-295.61013	2002-295.61411	2002-295.61412	2002-295.61413	2002-295.61411	2002-295.61412	2002-295.61413	
	CARBON STEEL		2002-295.60241	2002-295.60242	2002-295.60243	2002-295.60241	2002-295.60242	2002-295.60243	2002-295.63441	2002-295.63442	2002-295.63443	2002-295.63441	2002-295.63442	2002-295.63443	2002-295.61041	2002-295.61042	2002-295.61043	2002-295.61041	2002-295.61042	2002-295.61043	2002-295.61441	2002-295.61442	2002-295.61443	2002-295.61441	2002-295.61442	2002-295.61443	
	STAINLESS STEEL		2002-295.60221	2002-295.60222	2002-295.60223	2002-295.60221	2002-295.60222	2002-295.60223	2002-295.63421	2002-295.63422	2002-295.63423	2002-295.63421	2002-295.63422	2002-295.63423	2002-295.61021	2002-295.61022	2002-295.61023	2002-295.61021	2002-295.61022	2002-295.61023	2002-295.61421	2002-295.61422	2002-295.61423	2002-295.61421	2002-295.61422	2002-295.61423	

(*) Bronze. EN-1092-3.

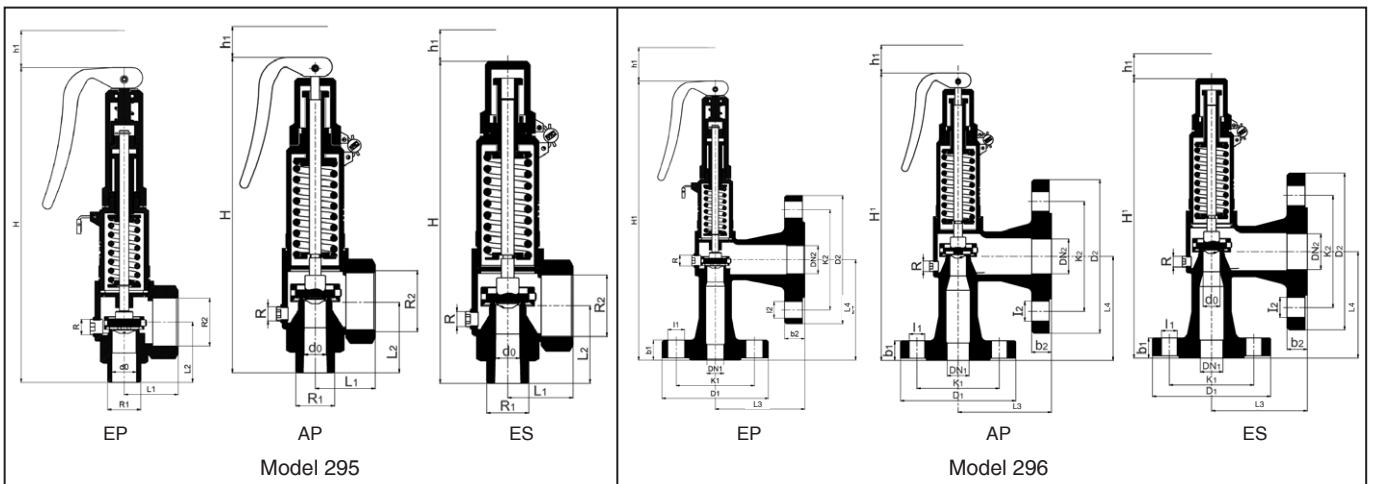

Pa = Overpressure permitted [bar] absolute.
 P = Set pressure [bar] absolute.

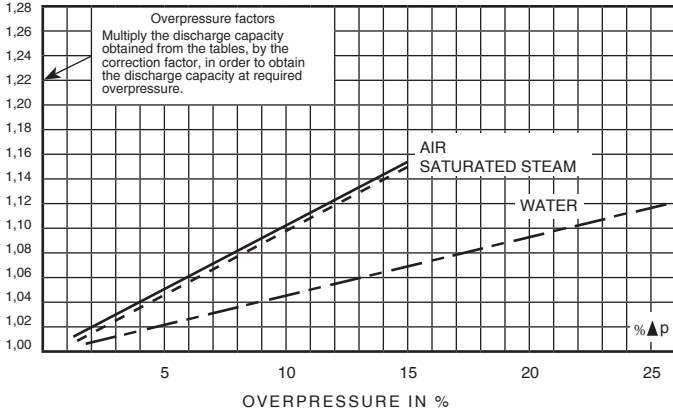

COEFFICIENT OF DISCHARGE FOR SATURATED STEAM AND GASES						
R1 x R2 DN1 x DN2		1/2" x 1" 15 x 25	3/4" x 1 1/4" 20 x 32	1" x 1 1/2" 25 x 40	1 1/4" x 2" 32 x 50	
d0		15	15	20	28	
h		2,20	3,75	5,00	7,00	
h/d0		0,14	0,25	0,25	0,25	
COEFFICIENT OF DISCHARGE kd	SATURATED STEAM GASES	SET PRESSURE IN bar				
		0,50 to 1,00	0,29	0,55	0,55	0,55
	1,00 to 25,00	0,35	0,62	0,62	0,62	
LIQUIDS		0,50 to 25,00	0,27	0,54	0,54	0,54

DISCHARGE CAPACITY												
R1 x R2 DN1 x DN2	1/2" x 1" 15 x 25		3/4" x 1 1/4" 20 x 32			1" x 1 1/2" 25 x 40			1 1/4" x 2" 32 x 50			
d0	15		15			20			28			
$A_0 = \frac{\pi \cdot d_0^2}{4}$	176,7		176,7			314,2			615,8			
P [bar]	<p>For other, not so dense liquids, other than water at 20°C apply:</p> $V_L = \sqrt{\frac{Q_A}{Q_L}} \cdot V_A \quad \text{ó} \quad V_A = V_L \cdot \sqrt{\frac{Q_L}{Q_A}}$ <p>I - Saturated steam in kg/h. II - Air at 0°C and 1,013 bar in [Nm³/h]. III - Water at 20°C in l/h.</p> <p>V_A = Water flow according to table. V_L = Liquid flow. Q_A = Water density at a 20°C. (Q_A = 998 kg/m³) Q_L = Liquid density.</p>											
SET PRESSURE IN bar	I	II	III	I	II	III	I	II	III	I	II	III
0,5	40	50	1780	76	92	3435	135	169	6114	264	331	11983
1,0	54	68	2517	102	128	4858	188	235	8647	369	461	16947
1,5	74	101	3082	137	160	5959	259	331	10590	507	649	20756
2,0	98	122	3560	175	220	6877	314	398	12229	616	779	23967
2,5	113	143	3980	202	255	7588	362	464	13672	709	909	26796
3,0	128	162	4360	229	290	8299	416	530	14977	814	1039	29353
3,5	144	183	4709	257	328	9010	463	596	16177	908	1169	31705
4,0	160	204	5034	285	360	9720	516	663	17294	1012	1299	33894
4,5	176	231	5339	323	395	10306	564	729	18343	1106	1429	35950
5,0	192	258	5628	361	430	10870	616	795	19335	1208	1559	37895
6,0	225	286	6165	400	510	11908	716	928	21180	1403	1818	41512
7,0	255	327	6659	452	580	12859	815	1060	22878	1597	2078	44838
8,0	285	368	7119	505	650	13745	914	1193	24457	1791	2338	47933
9,0	315	409	7551	560	723	14576	1013	1325	25941	1984	2598	50841
10,0	346	450	7959	615	800	15370	1111	1458	27344	2178	2857	53591
12,0	407	530	8719	720	940	16828	1308	1723	29954	2564	3377	58706
14,0	468	612	9417	880	1090	18185	1504	1988	32354	2947	3896	63410
16,0	525	694	10068	935	1230	19440	1701	2253	34588	3333	4416	67788
18,0	588	775	10678	1045	1380	20610	1896	2518	36686	3716	4935	71900
20,0	647	857	11256	1150	1520	21725	2092	2783	38670	4100	5455	75790
22,0	709	940	11805	1260	1665	22786	2288	3048	40558	4485	5975	79489
24,0	770	1020	12330	1370	1810	23799	2480	3313	42361	4860	6494	83023
25,0	810	1060	12535	1470	1881	24290	2582	3446	43235	5060	6754	84735

Calculus according to ISO-4126-1 "Safety valves"