



Multi-turn actuators

SA 07.2 – SA 16.2

SAR 07.2 – SAR 16.2

with actuator controls

AM 01.1/AM 02.1



Read operation instructions first.

- Observe safety instructions.
- These operation instructions are part of the product.
- Retain operation instructions during product life.
- Pass on instructions to any subsequent user or owner of the product.

Purpose of the document:

This document contains information for installation, commissioning, operation and maintenance staff. It is intended to support device installation and commissioning.

Reference documents:

Reference documents can be downloaded from the Internet (www.auma.com) or ordered directly from AUMA (refer to <Addresses>).

Table of contents		Page
1.	Safety instructions.....	5
1.1.	Basic information on safety	5
1.2.	Range of application	5
1.3.	Applications in Ex zone 22 (option)	6
1.4.	Warnings and notes	6
1.5.	References and symbols	7
2.	Identification.....	8
2.1.	Name plate	8
2.2.	Short description	11
3.	Transport, storage and packaging.....	12
3.1.	Transport	12
3.2.	Storage	14
3.3.	Packaging	15
4.	Assembly.....	16
4.1.	Mounting position	16
4.2.	Handwheel fitting	16
4.3.	Multi-turn actuator: mount to valve/gearbox	16
4.3.1.	Output drive type A	16
4.3.1.1.	Stem nut: finish machining	17
4.3.1.2.	Multi-turn actuator (with output drive type A): mount to valve	18
4.4.	Output drive types B and E	19
4.4.1.	Multi-turn actuator with output drive types B: mount to valve/gearbox	20
4.5.	Accessories for assembly	21
4.5.1.	Stem protection tube for rising valve stem	21
4.6.	Mounting positions of local controls	22
4.6.1.	Mounting positions: modify	23
5.	Electrical connection.....	24
5.1.	Basic information	24
5.2.	Electrical connection S/SH (AUMA plug/socket connector)	26
5.2.1.	Terminal compartment : open	27
5.2.2.	Cable connection	28
5.2.3.	Terminal compartment : close	29

5.3.	Accessories for electrical connection	30
5.3.1.	Actuator controls on wall bracket	30
5.3.2.	Parking frame	31
5.3.3.	DS intermediate frame for double sealing	31
5.3.4.	External earth connection	32
6.	Operation.....	33
6.1.	Manual operation	33
6.1.1.	Engage manual operation	33
6.1.2.	Manual operation: disengage	33
6.2.	Motor operation	34
6.2.1.	Local operation	34
6.2.2.	Actuator operation from remote	35
7.	Indications.....	36
7.1.	Indication lights	36
7.2.	Optional indications	36
7.2.1.	Mechanical position indication via indicator mark	36
8.	Signals (output signals).....	38
8.1.	Status signals via output contacts (digital outputs)	38
8.2.	Optional signals	38
8.2.1.	Analogue signals (analogue outputs)	38
9.	Commissioning (basic settings).....	39
9.1.	Heat-up time for low temperature version	39
9.2.	Switch compartment: open	39
9.3.	Torque switching: set	40
9.4.	Limit switching: set	40
9.4.1.	End position CLOSED (black section): set	41
9.4.2.	End position OPEN (white section): set	41
9.5.	Intermediate positions: set	42
9.5.1.	Running direction CLOSE (black section): set	42
9.5.2.	Running direction OPEN (white section): set	42
9.6.	Test run	43
9.6.1.	Direction of rotation at mechanical position indicator: check	43
9.6.2.	Direction of rotation at hollow shaft/stem: check	43
9.6.3.	Limit switching: check	44
9.6.4.	PTC tripping device (option): test	45
9.7.	Switch compartment: close	45
10.	Commissioning (optional equipment settings).....	46
10.1.	EWG 01.1 electronic position transmitter	46
10.1.1.	Measuring range: set	47
10.1.2.	Current values : adjust	47
10.1.3.	LED end position signalling: switch on/off	48
10.2.	Potentiometer	48
10.2.1.	Potentiometer: set	48
10.3.	RWG electronic position transmitter	49
10.3.1.	Measuring range: set	49
10.4.	Mechanical position indicator: set	50
11.	Commissioning – controls settings.....	51
11.1.	Actuator controls: open	51

11.2.	Type of seating: set	51
11.3.	Push-to-run operation or self-retaining: set	52
11.4.	Running indication (blinker transmitter): activate/deactivate	53
11.5.	Torque fault in collective fault signal: activate/deactivate	53
11.6.	LEDs for torque fault, phase failure, motor protection	53
11.7.	Positioner	54
11.7.1.	Input ranges (signal type) for setpoint and actual value	54
11.7.2.	Behaviour on loss of signal (actuator reaction)	55
11.7.3.	Adjustment in end positions	56
11.7.4.	Sensitivity setting	58
11.8.	EMERGENCY command (EMERGENCY - OPEN/EMERGENCY - CLOSE)	59
11.9.	Actuator controls: close	59
12.	Corrective action.....	61
12.1.	Faults during operation/commissioning	61
12.2.	Fuses	61
12.2.1.	Fuses within the actuator controls	61
12.2.2.	Motor protection (thermal monitoring)	63
13.	Servicing and maintenance.....	65
13.1.	Preventive measures for servicing and safe operation	65
13.2.	Maintenance	66
13.3.	Disposal and recycling	66
14.	Technical data.....	67
14.1.	Technical data Multi-turn actuators	67
14.2.	Technical data Actuator controls	70
15.	Spare parts.....	73
15.1.	Multi-turn actuators SA(V) 07.2 – SA(V) 16.2/SAR(V) 07.2 – SAR(V) 16.2	73
15.2.	Actuator controls AM 01.1/AM 02.1	75
16.	Certificates.....	77
16.1.	Declaration of Incorporation and EU Declaration of Conformity	77
	Index.....	78
	Addresses.....	81

1. Safety instructions

1.1. Basic information on safety

Standards/directives	<p>Our products are designed and manufactured in compliance with recognised standards and directives. This is certified in a Declaration of Incorporation and an EU Declaration of Conformity.</p> <p>The end user or the contractor must ensure that all legal requirements, directives, guidelines, national regulations and recommendations with respect to assembly, electrical connection, commissioning and operation are met at the place of installation.</p>
Safety instructions/warnings	<p>All personnel working with this device must be familiar with the safety and warning instructions in this manual and observe the instructions given. Safety instructions and warning signs on the device must be observed to avoid personal injury or property damage.</p>
Qualification of staff	<p>Assembly, electrical connection, commissioning, operation, and maintenance must be carried out by suitably qualified personnel authorised by the end user or contractor of the plant only.</p> <p>Prior to working on this product, the staff must have thoroughly read and understood these instructions and, furthermore, know and observe officially recognised rules regarding occupational health and safety.</p>
Commissioning	<p>Prior to commissioning, it is important to check that all settings meet the requirements of the application. Incorrect settings might present a danger to the application, e.g. cause damage to the valve or the installation. The manufacturer will not be held liable for any consequential damage. Such risk lies entirely with the user.</p>
Operation	<p>Prerequisites for safe and smooth operation:</p> <ul style="list-style-type: none">• Correct transport, proper storage, mounting and installation, as well as careful commissioning.• Only operate the device if it is in perfect condition while observing these instructions.• Immediately report any faults and damage and allow for corrective measures.• Observe recognised rules for occupational health and safety.• Observe national regulations.• During operation, the housing warms up and surface temperatures > 60 °C may occur. To prevent possible burns, we recommend checking the surface temperature using an appropriate thermometer and wearing protective gloves, if required, prior to working on the device.
Protective measures	<p>The end user or the contractor are responsible for implementing required protective measures on site, such as enclosures, barriers, or personal protective equipment for the staff.</p>
Maintenance	<p>To ensure safe device operation, the maintenance instructions included in this manual must be observed.</p> <p>Any device modification requires prior written consent of the manufacturer.</p>

1.2. Range of application

AUMA multi-turn actuators are designed for the operation of industrial valves, e.g. globe valves, gate valves, butterfly valves, and ball valves.

Other applications require explicit (written) confirmation by the manufacturer.

The following applications are not permitted, e.g.:

- Industrial trucks according to EN ISO 3691
- Lifting appliances according to EN 14502
- Passenger lifts according to DIN 15306 and 15309
- Service lifts according to EN 81-1/A1

- Escalators
- Continuous duty
- Buried service
- Continuous submersion (observe enclosure protection)
- Potentially explosive areas, with the exception of zone 22
- Radiation exposed areas in nuclear power plants

No liability can be assumed for inappropriate or unintended use.

Observance of these operation instructions is considered as part of the device's designated use.

Information These operation instructions are only valid for the "clockwise closing" standard version, i.e. driven shaft turns clockwise to close the valve.

1.3. Applications in Ex zone 22 (option)

Actuators of the indicated series basically meet the requirements for applications in dust hazardous locations of ZONE 22 in compliance with the ATEX directive 2014/34/EU.

To comply with all requirements of the ATEX directive, observe the following points:

- Actuators are marked with the explosion protection designation II3D... for use in ZONE 22.
- Maximum surface temperature of actuators
 - T150 °C for ambient temperatures up to +60 °C or
 - T190 °C for ambient temperatures up to +80 °C.

Increased dust deposit on the equipment was not considered for the determination of the maximum surface temperature.

- The following conditions must be fulfilled to respect the maximum permissible surface temperatures at the actuator:
 - Respecting types of duty and technical manufacturer data
 - Correct connection of thermal motor protection (thermoswitches or PTC thermistor)

Ambient temperature	Tripping temperature Thermal motor protection	Maximum surface temperature
up to +60 °C	140 °C	T150 °C
up to +80 °C	155 °C	T190 °C

- The connector may only be connected or disconnected when not live.
- The cable glands and cable entries used have to meet the requirements of category II3D and must at least comply with enclosure protection IP67.
- The actuators must be connected by means of an external earth connection (accessory part) to the equipotential earth bonding or integrated into an earthed piping system.
- To ensure combustible dust hazard protection, seal hollow shaft against ingress of dust:
 - Using threaded plug (ref. no. 511.0) and appropriate seal
 - Using metallic stem protection tube, protective cap and V-seal (ref. no. 568.1, 568.2, 568.3) for rising valve stem
- As a general rule, the requirements of IEC 60079 Parts 14 and 17 must be respected in dust hazardous locations. During commissioning, service, and maintenance, special care as well as qualified and trained personnel are required for safe actuator operation.

1.4. Warnings and notes

The following warnings draw special attention to safety-relevant procedures in these operation instructions, each marked by the appropriate signal word (DANGER, WARNING, CAUTION, NOTICE).



Indicates an imminently hazardous situation with a high level of risk. Failure to observe this warning could result in death or serious injury.



Indicates a potentially hazardous situation with a medium level of risk. Failure to observe this warning could result in death or serious injury.



Indicates a potentially hazardous situation with a low level of risk. Failure to observe this warning may result in minor or moderate injury. May also be used with property damage.



Potentially hazardous situation. Failure to observe this warning may result in property damage. Is not used for personal injury.

Arrangement and typographic structure of the warnings



Type of hazard and respective source!

Potential consequence(s) in case of non-observance (option)

- Measures to avoid the danger
- Further measure(s)

Safety alert symbol  warns of a potential personal injury hazard.

The signal word (here: DANGER) indicates the level of hazard.

1.5. References and symbols

The following references and symbols are used in these instructions:

Information

The term **Information** preceding the text indicates important notes and information.



Symbol for CLOSED (valve closed)



Symbol for OPEN (valve open)



Important information before the next step. This symbol indicates what is required for the next step or what has to be prepared or observed.



Reference to other sections

Terms in brackets shown above refer to other sections of the document which provide further information on this topic. These terms are either listed in the index, a heading or in the table of contents and may easily be located.

2. Identification

2.1. Name plate

Figure 1: Arrangement of name plates

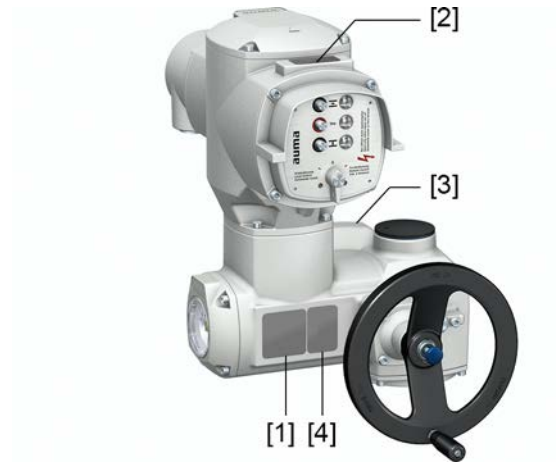

- [1] Actuator name plate
- [2] Actuator controls name plate
- [3] Motor name plate
- [4] Additional plate, e.g. KKS plate (Power Plant Classification System)

Actuator name plate

Figure 2: Actuator name plate (example)



auma (= manufacturer logo); **CE** (= CE mark)

- [1] Name of manufacturer
- [2] Address of manufacturer
- [3] **Type designation**
- [4] **Order number**
- [5] **Serial number**
- [6] Speed
- [7] Torque range in direction CLOSE
- [8] Torque range in direction OPEN
- [9] Type of lubricant
- [10] Permissible ambient temperature
- [11] Can be assigned as an option upon customer request
- [12] Enclosure protection
- [13] **Data Matrix code**

Actuator controls name plate

Figure 3: Actuator controls name plate

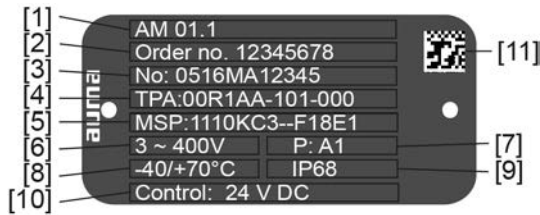

auma (= manufacturer logo)

- [1] **Type designation**
- [2] Order number
- [3] Serial number
- [4] Actuator terminal plan
- [5] Wiring diagram for controls
- [6] Mains voltage
- [7] **AUMA power class switchgear**
- [8] Permissible ambient temperature
- [9] Enclosure protection
- [10] **Control**
- [11] Data Matrix code

Motor name plate

Figure 4: Motor name plate (example)



auma (= manufacturer logo); **CE** (= CE mark)

- [1] Motor type
- [2] Motor article number
- [3] Serial number
- [4] Current type, mains voltage
- [5] Rated power
- [6] Rated current
- [7] Type of duty
- [8] Enclosure protection
- [9] Motor protection (temperature protection)
- [10] Insulation class
- [11] Speed
- [12] Power factor cos phi
- [13] Mains frequency
- [14] Data Matrix code

Descriptions referring to name plate indications

Type designation Figure 5: Type designation (example)

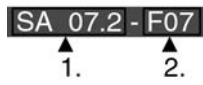

1. Type and size of actuator
2. Flange size

Type and size

These instructions apply to the following devices types and sizes:

- Type SA = Multi-turn actuators for open-close duty
Sizes: SA 07.2, 07.6, 10.2, 14.2, 14.6, 16.2
- Type SAR = Multi-turn actuators for modulating duty
Sizes: 07.2, 07.6, 10.2, 14.2, 14.6, 16.2
- Type AM = AUMA MATIC actuator controls
Sizes: 01.1, 02.1

Order number The product can be identified using this number and the technical data as well as order-related data pertaining to the device can be requested.

Please always state this number for any product inquiries.

On the Internet at <http://www.auma.com> > Service & Support >myAUMA, we offer a service allowing authorised users to download order-related documents such as wiring diagrams and technical data (both in German and English), inspection certificate and the operation instructions when entering the order number.

Actuator serial number

Table 1:

Description of serial number (with example 0516MD12345)		
05	16	MD12345
05	Positions 1+2: Assembly in week = week 05	
	16	Positions 3+4: Year of manufacture = 2016
		MD12345 Internal number for unambiguous product identification

AUMA power class for switchgear

The switchgear used in the actuator controls (reversing contactors/thyristors) are classified according to AUMA power classes (e.g. A1, B1,). The power class defines the max. permissible rated power (of the motor) the switchgear has been designed for. The rated power (nominal power) of the actuator motor is indicated in kW on the motor name plate. For the assignment of the AUMA power classes to the nominal power of the motor types, refer to the separate electrical data sheets.

For switchgear without assignment to any power classes, the actuator controls name plate does not indicate the power class but the max. rated power in kW.

Control

Table 2:

Control examples (indications on actuator controls name plate)	
Input signal	Description
24 V DC	Control voltage 24 V DC for OPEN - CLOSE control via digital inputs (OPEN, STOP, CLOSE)
48 V DC	Control voltage 48 V DC OPEN - CLOSE control via digital inputs (OPEN, STOP, CLOSE)
60 V DC	Control voltage 60 V DC OPEN - CLOSE control via digital inputs (OPEN, STOP, CLOSE)
115 V AC	Control voltage 115 V AC for OPEN - CLOSE control via digital inputs (OPEN, STOP, CLOSE)
0/4 – 20 mA	Input current for setpoint control via analogue input

Data Matrix code When registered as authorised user, you may use our **AUMA Assistant App** to scan the Data Matrix code and directly access the order-related product documents without having to enter order number or serial number.

Figure 6: Link to AUMA Assistant App:



For further Service & Support, software/apps/... refer to www.auma.com.

2.2. Short description

- Multi-turn actuator** Definition in compliance with EN 15714-2/EN ISO 5210:
A multi-turn actuator is an actuator which transmits torque to a valve for at least one full revolution. It is capable of withstanding thrust.
AUMA multi-turn actuators SA 07.2 – SA 16.2/SAR 07.2 – SAR16.2 are driven by an electric motor and are capable of withstanding thrust in combination with output drive type A. For manual operation, a handwheel is provided. Switching off in end positions may be either by limit or torque seating. Actuator controls are required to operate or process the actuator signals.
- Actuator controls** AM 01.1/AM02.1 actuator controls are used to operate AUMA actuators and are supplied ready for use. The actuator controls may be mounted directly to the actuator or separately on a wall bracket. The functions of AM 01.1/AM02.1 actuator controls include standard valve control in OPEN-CLOSE duty, position indications and different signals right through to position control (option).
- Local controls** Operation (via push-buttons), setting and indication can be performed directly at the actuator controls (contents of these instructions).

3. Transport, storage and packaging

3.1. Transport

For transport to place of installation, use sturdy packaging.



Hovering load!

Risk of death or serious injury.

- Do NOT stand below hovering load.
- Attach ropes or hooks for the purpose of lifting by hoist only to housing and NOT to handwheel.
- Actuators mounted on valves: Attach ropes or hooks for the purpose of lifting by hoist to valve and NOT to actuator.
- Actuators mounted to gearboxes: Attach ropes or hooks for the purpose of lifting by hoist only to the gearbox using eyebolts and NOT to the actuator.
- Actuators mounted to controls: Attach ropes or hooks for the purpose of lifting by hoist only to the actuator and NOT to the controls.
- Respect total weight of combination (actuator, actuator controls, gearbox, valve)
- Secure load against falling down, sliding or tilting.
- Perform lift trial at low height to eliminate any potential danger e.g. by tilting.

Figure 7: Example: Lifting the actuator



Table 3:

Weight of AM 01.1/AM 02.1 actuator controls	
Electrical connection	Weight approx. [kg]
AUMA plug/socket connector with screw-type connection	7

Table 4:

Weights for multi-turn actuators SA 07.2 – SA 16.2 / SAR 07.2 – SAR 16.2 with 3-phase AC motors		
Type designation Actuator	Motor type ¹⁾	Weight ²⁾
		approx. [kg]
SA 07.2/ SAR 07.2	VD...	19
	AD...	20
SA 07.6/ SAR 07.6	VD...	20
	AD...	21

Weights for multi-turn actuators SA 07.2 – SA 16.2 / SAR 07.2 – SAR 16.2 with 3-phase AC motors		
Type designation Actuator	Motor type ¹⁾	Weight ²⁾
		approx. [kg]
SA 10.2/ SAR 10.2	VD...	22
	AD...	25
SA 14.2/ SAR 14.2	VD...	44
	AD...	48
SA 14.6/ SAR 14.6	VD...	46
	AD...	53
SA 16.2/ SAR 16.2	VD...	67
	AD...	83

- 1) Refer to motor name plate
- 2) Indicated weight includes AUMA NORM multi-turn actuator with 3-phase AC motor, electrical connection in standard version, output drive type B1 and handwheel. For other output drive types, heed additional weights.

Table 5:

Weights for multi-turn actuators SA 07.2 – SA 16.2 / SAR 07.2 – SAR 16.2 With 1-phase AC motors		
Type designation Actuator	Motor type ¹⁾	Weight ²⁾
		approx. [kg]
SA 07.2/ SAR 07.2	VB...	21
	VE...	21
	AE...	28
SA 07.6/ SAR 07.6	VB...	21
	VE...	25
	AE...	28
	AC...	37
SA 10.2/ SAR 10.2	VE...48-4...	28
	VE...48-2...	31
	AC... 56-4...	40
	AC... 56-2...	43
SA 14.2/ SAR 14.2	VE...	59
	VC...	61
	AC...	63
SA 14.6/ SAR 14.6	VE...	63
	VC...	66

- 1) Refer to motor name plate
- 2) Indicated weight includes AUMA NORM multi-turn actuator with 1-phase AC motor, electrical connection in standard version, output drive type B1 and handwheel. For other output drive types, heed additional weights.

Table 6:

Weights for multi-turn actuators SA 07.2 – SA 16.2 / SAR 07.2 – SAR 16.2 With DC motors		
Type designation Actuator	Motor type ¹⁾	Weight ²⁾
		approx. [kg]
SA 07.2/ SAR 07.2	FN... 63-...	29
	FN... 71-...	32
SA 07.6/ SAR 07.6	FN... 63-...	30
	FN... 80-...	44

Weights for multi-turn actuators SA 07.2 – SA 16.2 / SAR 07.2 – SAR 16.2		
With DC motors		
Type designation Actuator	Motor type ¹⁾	Weight ²⁾ approx. [kg]
SA 10.2/ SAR 10.2	FN... 63-...	33
	FN... 71-...	36
	FN... 90-...	56
SA 14.2/ SAR 14.2	FN... 71-... / FN... 80-...	68
	FN... 90-...	100
SA 14.6/ SAR 14.6	FN... 80-... / FN... 90-...	76
	FN... 112-...	122
SA 16.2/ SAR 16.2	FN... 100-...	123

1) Refer to motor name plate

2) Indicated weight includes AUMA NORM multi-turn actuator with DC motor, electrical connection in standard version, output drive type B1 and handwheel. For other output drive types, heed additional weights.

Table 7:

Weights for output drive type A 07.2 – A 16.2		
Type designation	Flange size	[kg]
A 07.2	F07	1.1
A 10.2	F10	2.8
A 14.2	F14	6.8
A 16.2	F16	11.7

Table 8:

Weights for output drive type AF 07.2 – AF 16.2		
Type designation	Flange size	[kg]
AF 07.2	F10	5.2
AF 07.6	F10	5.2
AF 10.2	F10	5.5
AF 14.2	F14	13.7
AF 16.2	F16	23

3.2. Storage

NOTICE

Danger of corrosion due to inappropriate storage!

- Store in a well-ventilated, dry room.
- Protect against floor dampness by storage on a shelf or on a wooden pallet.
- Cover to protect against dust and dirt.
- Apply suitable corrosion protection agent to uncoated surfaces.

NOTICE

Damage due to excessively low storage temperatures!

- AUMA MATIC actuator controls may NOT be stored below –40 °C

Long-term storage

For long-term storage (more than 6 months), observe the following points:

1. Prior to storage:
Protect uncoated surfaces, in particular the output drive parts and mounting surface, with long-term corrosion protection agent.

2. At an interval of approx. 6 months:
Check for corrosion. If first signs of corrosion show, apply new corrosion protection.

3.3. Packaging

Our products are protected by special packaging for transport when leaving the factory. The packaging consists of environmentally friendly materials which can easily be separated and recycled. We use the following packaging materials: wood, cardboard, paper, and PE foil. For the disposal of the packaging material, we recommend recycling and collection centres.

4. Assembly

4.1. Mounting position

The product described in this document can be operated in any mounting position.

Restriction: When using oil instead of grease within the actuator gear housing, the hollow shaft mounting position must be perpendicular, with the flange pointing downward. The type of lubricant used is indicated on the actuator name plate (short designation **F**...= grease; **O**...= oil).

4.2. Handwheel fitting

Information For transport reason, handwheels with a diameter of 400 mm and larger are supplied separately within the scope of delivery.

Figure 8: Handwheel

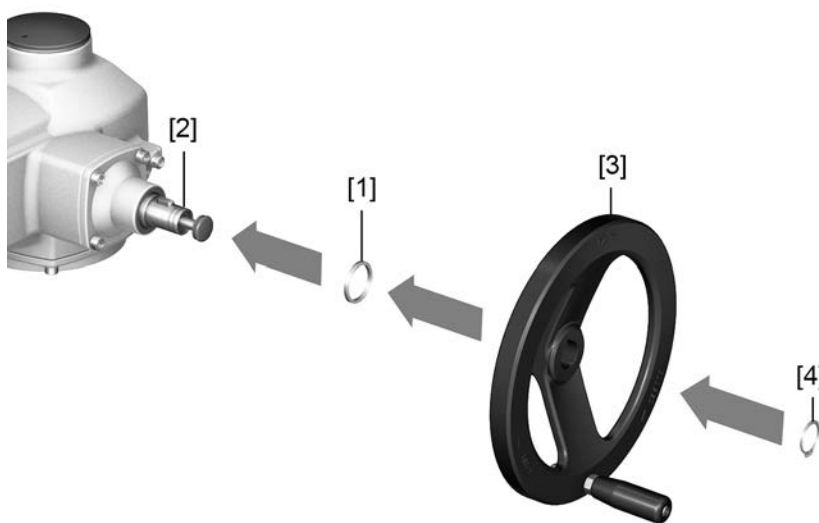

- [1] Spacer
- [2] Input shaft
- [3] Handwheel
- [4] Retaining ring

1. If required, fit spacer [1] on input shaft [2].
2. Slip handwheel [3] onto input shaft.
3. Secure handwheel [3] using the retaining ring [4] supplied.

Information The retaining ring [4] (together with these operation instructions) is stored in a weatherproof bag, which is attached to the device prior to delivery.

4.3. Multi-turn actuator: mount to valve/gearbox

NOTICE

Danger of corrosion due to damage to paint finish and condensation!

- Touch up damage to paint finish after work on the device.
- After mounting, connect the device immediately to electrical mains to ensure that heater minimises condensation.

4.3.1. Output drive type A

- Application**
- Output drive for rising, non-rotating valve stem
 - Capable of withstanding thrust

Design Output mounting flange [1] with axial bearing stem nut [2] form one unit. Torque is transmitted to valve stem [3] via stem nut [2].

Figure 9: Design of output drive type A

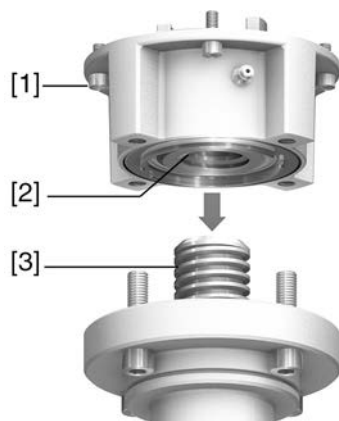

- [1] Output mounting flange
- [2] Stem nut with dog coupling
- [3] Valve stem

Information To adapt the actuators to available output drive types A with flanges F10 and F14 (year of manufacture: 2009 and earlier), an adapter is required. The adapter can be ordered from AUMA.

4.3.1.1. Stem nut: finish machining

✓ This working step is only required if stem nut is supplied unbored or with pilot bore.

Figure 10: Output drive type A

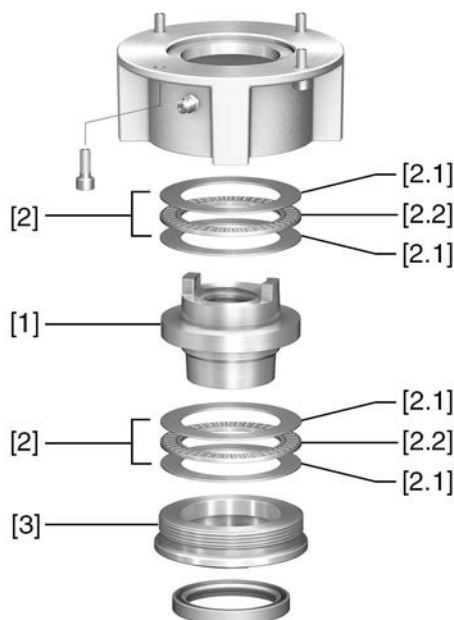

- [1] Stem nut
- [2] Axial needle roller bearing
- [2.1] Axial bearing washer
- [2.2] Axial needle roller and cage assembly
- [3] Spigot ring

1. Remove spigot ring [3] from output drive.
2. Remove stem nut [1] together with axial needle roller bearings [2].

3. Remove axial bearing washers [2.1] and axial needle roller and cage assemblies [2.2] from stem nut [1].
4. Drill and bore stem nut [1] and cut thread.
Information: When fixing in the chuck, make sure stem nut runs true!
5. Clean the machined stem nut [1].
6. Apply sufficient Lithium soap EP multi-purpose grease to axial needle roller and cage assemblies [2.2] and axial bearing washers [2.1], ensuring that all hollow spaces are filled with grease.
7. Place greased axial needle roller and cage assemblies [2.2] and axial bearing washers [2.1] onto stem nut [1].
8. Re-insert stem nut [1] with bearings [2] into output drive.
Information: Ensure that dogs or splines are placed correctly in the keyway of the hollow shaft.
9. Screw in spigot ring [3] until it is firm against the shoulder.

4.3.1.2. Multi-turn actuator (with output drive type A): mount to valve

Figure 11: Assembly of output drive type A

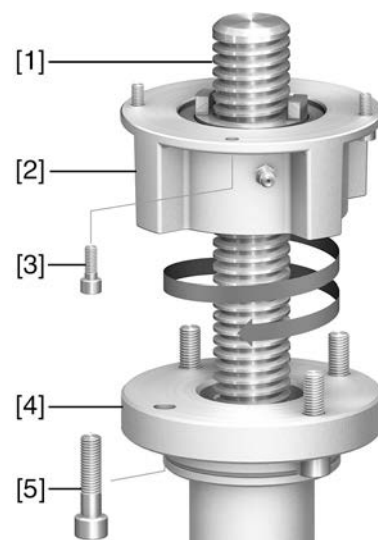

- | | |
|-----|------------------------|
| [1] | Valve stem |
| [2] | Output drive type A |
| [3] | Screws to actuator |
| [4] | Valve flange |
| [5] | Screws to output drive |

1. If the output drive type A is already mounted to the multi-turn actuator: Loosen screws [3] and remove output drive type A [2].
2. Check if the flange of output drive type A matches the valve flange [4].
3. Apply a small quantity of grease to the valve stem [1].
4. Place output drive type A on valve stem and turn until it is flush on the valve flange.
5. Turn output drive type A until alignment of the fixing holes.
6. Screw in fastening screws [5], however do not completely tighten.
7. Fit multi-turn actuator on the valve stem so that the stem nut dogs engage into the output drive sleeve.
➡ The flanges are flush with each other if properly engaged.
8. Adjust multi-turn actuator until alignment of the fixing holes.
9. Fasten multi-turn actuator with screws [3].

10. Fasten screws [3] crosswise with a torque according to table.

Table 9:

Tightening torques for screws	
Threads	Tightening torque [Nm]
	Strength class A2-80/A4-80
M6	10
M8	24
M10	48
M12	82
M16	200
M20	392

11. Turn multi-turn actuator with handwheel in direction OPEN until valve flange and output drive A are firmly placed together.
12. Tighten fastening screws [5] between valve and output drive type A crosswise applying a torque according to table.

4.4. Output drive types B and E

- Application**
- For rotating, non-rising valve stem
 - Not capable of withstanding thrust

Design Connection between hollow shaft and valve or gearbox via output drive sleeve fixed to the hollow shaft of the multi-turn actuator via retaining ring.

When exchanging the output drive sleeve, later retrofitting to a different output drive type is possible

- Output drive types B and E: Output drive sleeve with bore according to DIN 3210
- Output drive types B1 – B4: Output drive sleeve with bore according to EN ISO 5210

Figure 12: Output drive type B

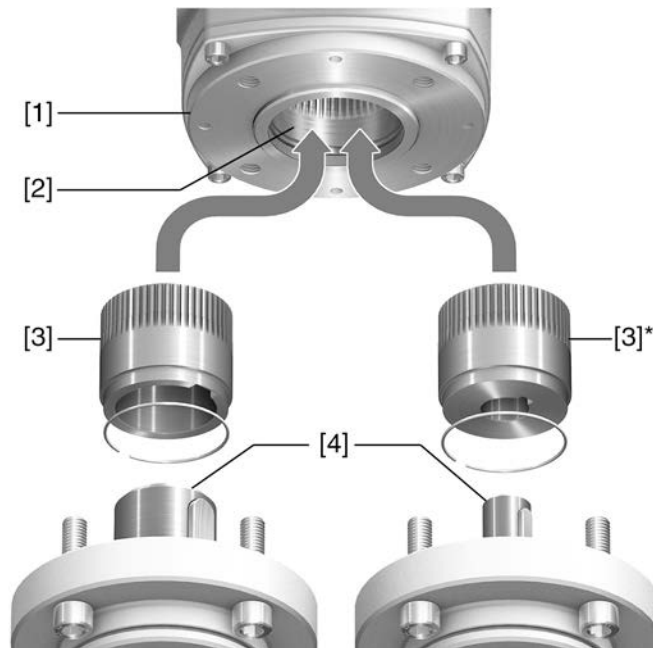

- [1] Flange multi-turn actuator (e.g. F07)
- [2] Hollow shaft
- [3] Output drive sleeve (illustration examples)
[3] B/B1/B2 and [3]* B3/B4/E, respectively with bore and keyway
- [4] Gearbox/valve shaft with parallel key

Information Spigot at valve flanges should be loose fit.

4.4.1. Multi-turn actuator with output drive types B: mount to valve/gearbox

Figure 13: Mounting output drive types B

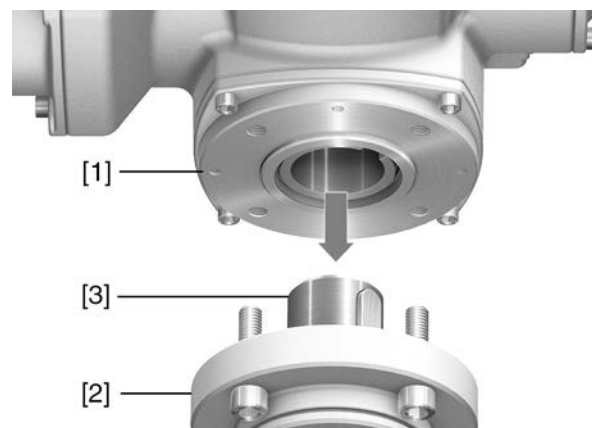

- [1] Multi-turn actuator
- [2] Valve/gearbox
- [3] Valve/gearbox shaft

1. Check if mounting flanges fit together.
2. Check if output drive of multi-turn actuator [1] matches the output drive of valve/gearbox or valve/gearbox valve shaft [2/3].
3. Apply a small quantity of grease to the valve or gearbox shaft [3].
4. Fit multi-turn actuator [1].

Information: Ensure that the spigot fits uniformly in the recess and that the mounting faces are in complete contact.

5. Fasten multi-turn actuator with screws according to table.
Information: We recommend applying liquid thread sealing material to the screws to avoid contact corrosion.
6. Fasten screws crosswise to a torque according to table.

Table 10:

Tightening torques for screws	
Threads	Tightening torque [Nm]
	Strength class A2-80/A4-80
M6	10
M8	24
M10	48
M12	82
M16	200
M20	392

4.5. Accessories for assembly

4.5.1. Stem protection tube for rising valve stem

Figure 14: Assembly of the stem protection tube

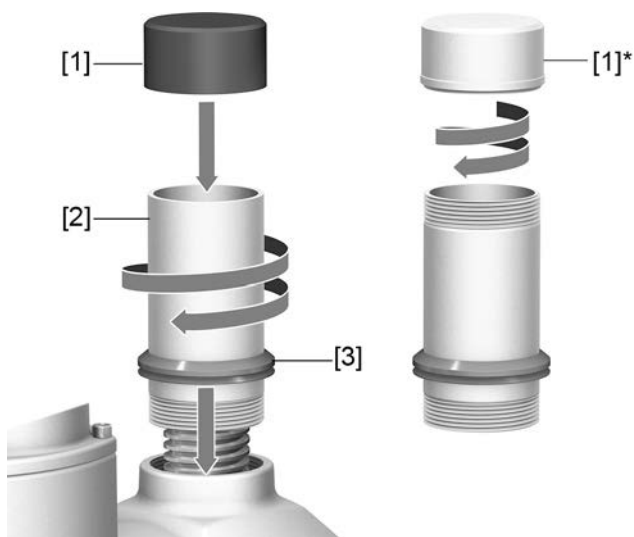

- [1] Protective cap for stem protection tube (fitted)
- [1]* Option: Protective cap made of steel (screwed)
- [2] Stem protection tube
- [3] V-seal

1. Seal all threads with hemp, Teflon tape, or thread sealing material.

- Screw stem protection tube [2] into thread and tighten it firmly.

Information: For stem protection tubes made of two or more segments, all parts have to be thoroughly screwed together.

Figure 15: Protection tube made of segments with threaded sleeves (>900 mm)

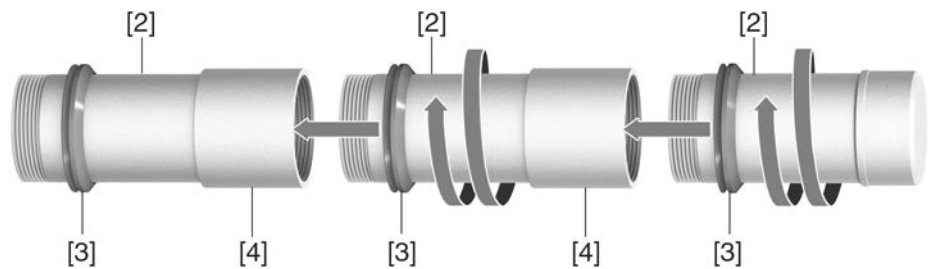

- [2] Segment of stem protection tube
- [3] V-seal
- [4] Threaded sleeve

- Push down the sealing ring [3] onto the housing.

Information: For mounting segments, push down seals of segments down to the sleeve (connecting piece).

- Check whether protective cap [1] for stem protection tube is available, in perfect condition and tightly placed on or screwed to the tube.

NOTICE

Risk of bending or oscillation of protection tubes exceeding a length of 2 m!

Risk of damage at stem and/or protection tube.

→ Secure protection tubes exceeding 2 m by an appropriate support.

4.6. Mounting positions of local controls

The mounting position of the local controls is designed according to the order. If, after mounting the actuator to the valve or the gearbox on site, the local controls are in an unfavourable position, the mounting position can be changed at a later date. Four mounting positions shifted by respectively 90° are possible.

Figure 16: Mounting positions



4.6.1. Mounting positions: modify

 **DANGER**

Hazardous voltage!

Risk of electric shock.

→ Disconnect device from the mains before opening.

1. Loosen screws and remove local controls.
 2. Loosen 3 screws of the board, turn board to the new position and fasten the screws.
 3. Check whether O-ring is in good condition, correctly insert O-ring.
 4. Turn local controls into new position and re-place.
-

NOTICE

Cable damage due to twisting or pinching!

Risk of functional failures.

→ Turn local controls by a maximum of 180°.

→ Carefully assemble local controls to avoid pinching the cables.

5. Fasten screws evenly crosswise.

5. Electrical connection

5.1. Basic information



Danger due to incorrect electrical connection

Failure to observe this warning can result in death, serious injury, or property damage.

- The electrical connection must be carried out exclusively by suitably qualified personnel.
- Prior to connection, observe basic information contained in this chapter.
- After connection but prior to applying the voltage, observe the <Commissioning> and <Test run> chapters.

Wiring diagram/terminal plan

The pertaining wiring diagram/terminal plan (in German or English) is attached to the device in a weather-proof bag, together with these operation instructions. It can also be requested from AUMA (state order number, refer to name plate) or downloaded directly from the Internet (<http://www.auma.com>).

Permissible networks (supply networks)

Actuator controls (actuators) are suitable for use in TN and TT networks with directly earthed star point for mains voltage up to maximum V AC. Use in IT networks for nominal voltages up to maximum V AC are permissible. For IT network, a suitable, approved insulation monitor measuring the pulse code is required.

Current type, mains voltage, mains frequency

Type of current, mains voltage and mains frequency must match the data on the actuator controls and motor name plates. Also refer to chapter <Identification>/<Name plate>.

Figure 17: Motor name plate (example)

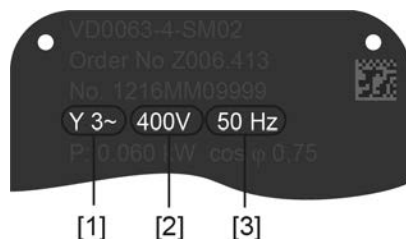

- [1] Type of current
- [2] Mains voltage
- [3] Mains frequency (for 3-phase and 1-phase AC motors)

External supply of the electronics

If electronics is supplied externally with 24 V DC, the power supply is smoothed via an internal 1,000 µF capacitor). When selecting the power supply, care must be taken to consider the capacitor inrush current upon powering up the unit.

Protection and sizing on site

For short-circuit protection and for disconnecting the actuator from the mains, fuses and disconnect switches have to be provided by the customer.

The current values for sizing the protection can be derived from the current consumption of the motor (refer to motor name plate) plus the current consumption of actuator controls.

We recommend adapting the switchgear sizing to the max. current (I_{max}) and selecting and setting the overcurrent protection device in compliance with the indications in the electrical data sheet.

Table 11:

Current consumption controls	
Mains voltage	Max. current consumption
100 to 120 V AC ($\pm 10\%$)	575 mA
208 to 240 V AC ($\pm 10\%$)	275 mA
380 to 500 V AC ($\pm 10\%$)	160 mA
24 V DC (+20 %/-15 %) and AC motor	500 mA

Table 12:

Maximum permissible protection		
Switchgear (switchgear with power class) ¹⁾	Rated power	max. protection
Reversing contactor A1	up to 1.5 kW	16 A (gL/gG)
Reversing contactor A2	up to 7.5 kW	32 A (gL/gG)
Reversing contactor A3	up to 15 kW	63 A (gL/gG)
Thyristor B1	up to 1.5 kW	16 A (g/R) $I^2t < 1,500A^2s$
Thyristor B2	up to 3 kW	32 A (g/R) $I^2t < 1,500A^2s$
Thyristor B3	up to 5.5 kW	63 A (g/R) $I^2t < 5,000A^2s$

1) The AUMA power class (A1, B1, ...) is indicated on the actuator controls name plate

Consider the motor starting current (I_A) (refer to electrical data sheet) when selecting the circuit breaker. We recommend tripping characteristics D or K for circuit breakers in accordance with IEC 60947-2. For controls with thyristors, we recommend safety fuses instead of circuit breakers.

We recommend refraining from using residual current devices (RCD). However, if an RCD is used within the mains, the residual current device must be of type B.

If actuator controls are mounted separately from actuator (actuator controls on wall bracket): Consider length and cross section of connecting cable when defining the protection required.

Potential of customer connections

All input signals (control inputs) must be supplied with the same potential.

All output signals (status signals) must be supplied with the same potential.

Safety standards

Safety measures and safety equipment must comply with the respectively valid national on site specifications. All externally connected devices shall comply with the relevant safety standards for the place of installation.

Connecting cables

- We recommend using connecting cables and connecting terminals according to rated current (I_N) (refer to motor name plate or electrical data sheet).
- For device insulation, appropriate (voltage-proof) cables must be used. Specify cables for the highest occurring rated voltage.
- Use connecting cable with appropriate minimum rated temperature.
- For connecting cables exposed to UV radiation (outdoor installation), use UV resistant cables.
- For the connection of position transmitters, screened cables must be used.

Cable installation in accordance with EMC

Signal and fieldbus cables are susceptible to interference. Motor cables are interference sources.

- Lay cables being susceptible to interference or sources of interference at the highest possible distance from each other.
- The interference immunity of signal and fieldbus cables increases if the cables are laid close to the earth potential.
- If possible, avoid laying long cables and make sure that they are installed in areas being subject to low interference.

- Avoid parallel paths with little cable distance of cables being either susceptible to interference or interference sources.

5.2. Electrical connection S/SH (AUMA plug/socket connector)

Figure 18: S and SH electrical connection

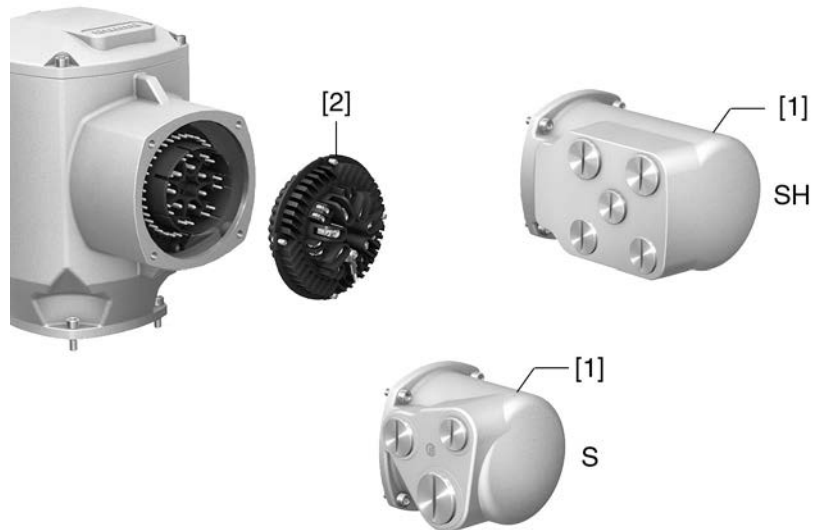

- [1] Cover
- [2] Socket carrier with screw-type terminals

Short description Plug-in electrical connection with screw-type terminals for power and control contacts. Control contacts also available as crimp-type connection as an option.

S version (standard) with three cable entries. SH version (enlarged) with additional cable entries. For cable connection, remove the AUMA plug/socket connector and the socket carrier from cover.

Technical data

Table 13:

Electrical connection via AUMA plug/socket connector		
	Power contacts	Control contacts
No. of contacts max.	6 (3 equipped) + protective earth conductor (PE)	50 pins/sockets
Designation	U1, V1, W1, U2, V2, W2, PE	1 to 50
Connection voltage max.	750 V	250 V
Rated current max.	25 A	16 A
Type of customer connection	Screw connection	Screw connection, crimp-type (option)
Connection diameter max.	6 mm ² (flexible) 10 mm ² (solid)	2.5 mm ² (flexible or solid)

Information For some special motors, the connection of the power terminals (U1, V1, W1, U2, V2, W2) is **not** performed via the AUMA plug/socket connector but via a terminal board directly at the motor.

5.2.1. Terminal compartment : open

Figure 19: Open terminal compartment

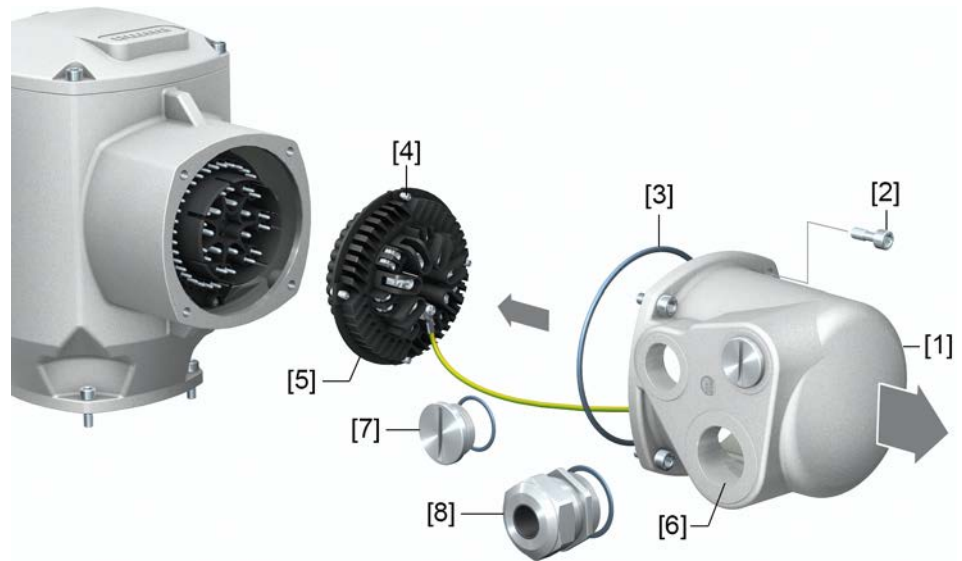

- [1] Cover (figure shows S version)
- [2] Screws for cover
- [3] O-ring
- [4] Screws for socket carrier
- [5] Socket carrier
- [6] Cable entry
- [7] Blanking plugs
- [8] Cable gland (not included in delivery)



Hazardous voltage!

Risk of electric shock.

→ Disconnect device from the mains before opening.

1. Loosen screws [2] and remove cover [1].
 2. Loosen screws [4] and remove socket carrier [5] from cover [1].
 3. Insert cable glands [8] suitable for connecting cables.
- ➔ The enclosure protection IP... stated on the name plate is only ensured if suitable cable glands are used.

Figure 20: Example: Name plate for enclosure protection IP68

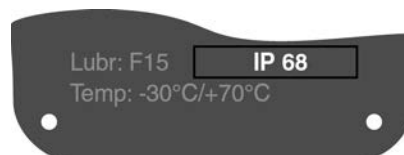

4. Seal unused cable entries [6] with suitable blanking plugs [7].

5.2.2. Cable connection

Table 14:

Terminal cross sections and terminal tightening torques		
Designation	Terminal cross sections	Tightening torques
Power contacts (U1, V1, W1, U2, V2, W2)	1.0 – 6 mm ² (flexible) 1.5 – 10 mm ² (solid)	1.2 – 1.5 Nm
Protective earth connection ⊕ (PE)	1.0 – 6 mm ² (flexible) with ring lugs 1.5 – 10 mm ² (solid) with loops	1.2 – 2.2 Nm
Control contacts (1 to 50)	0.25 – 2.5 mm ² (flexible) 0.34 – 2.5 mm ² (solid)	0.5 – 0.7 Nm

1. Remove cable sheathing.
2. Insert the wires into the cable glands.
3. Fasten cable glands with the specified torque to ensure required enclosure protection.
4. Strip wires.
→ Controls approx. 6 mm, motor approx. 10 mm
5. For flexible cables: Use wire end sleeves according to DIN 46228.
6. Connect cables according to order-related wiring diagram.



In case of a fault: Hazardous voltage while protective earth conductor is NOT connected!

Risk of electric shock.

- Connect all protective earth conductors.
- Connect PE connection to external protective earth conductor of connecting cables.
- Start running the device only after having connected the protective earth conductor.

7. Tighten PE conductors firmly to PE connection using ring lugs (flexible cables) or loops (solid cables).

Figure 21: Protective earthing

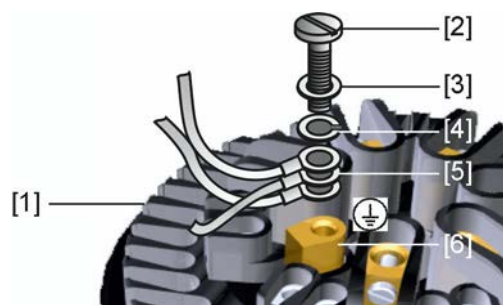

- [1] Socket carrier
- [2] Screw
- [3] Washer
- [4] Lock washer
- [5] Protective earth with ring lugs/loops
- [6] Protective earthing, symbol: ⊕

8. For shielded cables: Link the cable shield end via the cable gland to the housing (earthing).

5.2.3. Terminal compartment : close

Figure 22: Close terminal compartment

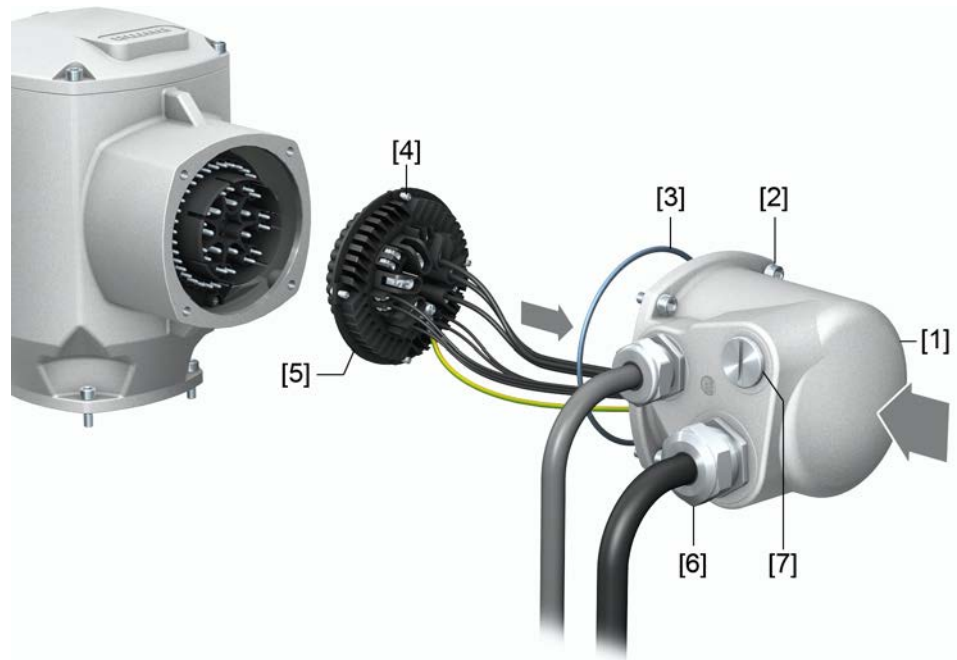

- [1] Cover (figure shows S version)
- [2] Screws for cover
- [3] O-ring
- [4] Screws for socket carrier
- [5] Socket carrier
- [6] Cable gland (not included in delivery)
- [7] Blanking plug



Short-circuit due to pinching of cables!

Risk of electric shock and functional failures.

→ Carefully fit socket carrier to avoid pinching the cables.

1. Insert the socket carrier [5] into the cover [1] and fasten with screws [4].
2. Clean sealing faces of cover [1] and housing.
3. Check whether O-ring [3] is in good condition, replace if damaged.
4. Apply a thin film of non-acidic grease (e.g. petroleum jelly) to the O-ring and insert it correctly.
5. Fit cover [1] and fasten screws [2] evenly crosswise.
6. Fasten cable glands and blanking plugs applying the specified torque to ensure the required enclosure protection.

5.3. Accessories for electrical connection

5.3.1. Actuator controls on wall bracket

Figure 23: Setup with wall bracket (example with S electrical connection)

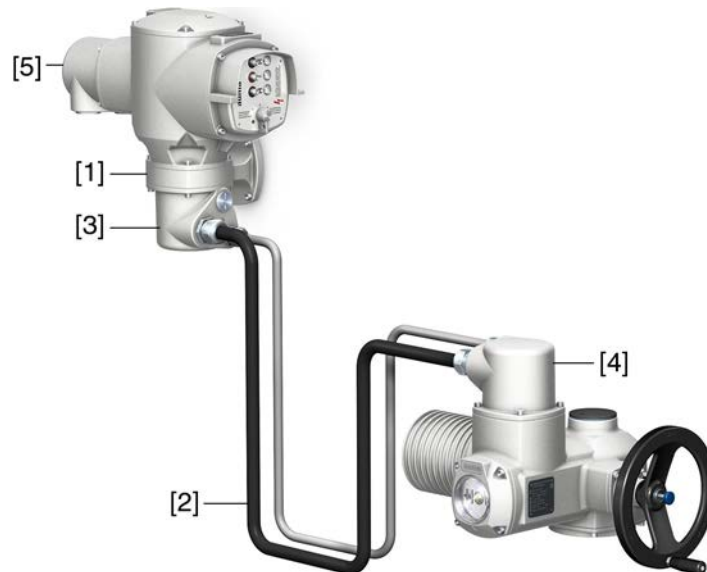

- [1] Wall bracket
- [2] Connecting cables
- [3] Electrical connection of wall bracket (XM)
- [4] Electrical connection of actuator (XA)
- [5] Electrical connection of actuator controls (XK) - customer plug

Application The wall bracket allows separate mounting of actuator controls and actuator.

- If access to the mounted actuator is restricted.,
- If the actuator is subjected to high temperatures.
- In case of heavy vibration of the valve.

Information on installation with wall bracket

- The permissible cable length between actuator controls on wall bracket and the actuator amounts to 100 m maximum.
- We recommend using an AUMA cable set "LSW".
- If the actuator is equipped with a position transmitter (EWG, RWG, potentiometer):
 - Use suitable flexible and screened connecting cables.
 - Earth cable shield at both ends.
- When using connecting cables, e.g. of the heater or switch, requiring direct wiring from the actuator to the XK customer plug (XA-XM-XK, refer to wiring diagram), these connecting cables must be subject to an insulation test in compliance with EN 50178. Connecting cables of position transmitters (EWG, RWG, IWG, potentiometer) do not belong to this group. They may **not** be subjected to an insulation test.

5.3.2. Parking frame

Figure 24: Parking frame, example with S plug/socket connector and cover



Application Parking frame for safe storage of a disconnected plug or cover.
For protection against touching the bare contacts and against environmental influences.

5.3.3. DS intermediate frame for double sealing

Figure 25: Electrical connection with DS intermediate frame

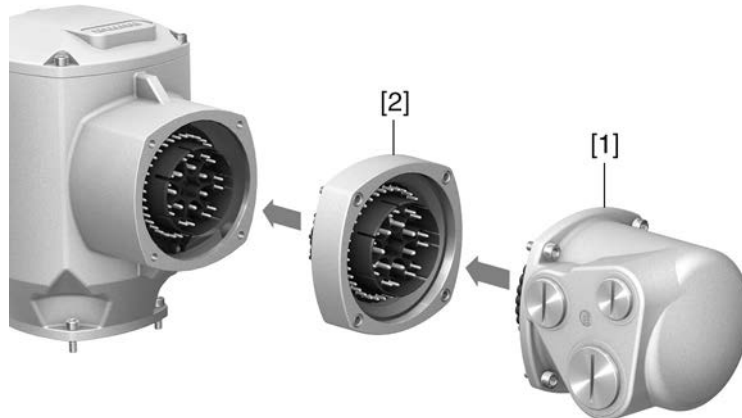

- [1] Electrical connection
- [2] DS intermediate frame

Application When removing the electrical connection or due to leaky cable glands, there is a potential risk of ingress of dust and water into the housing. This is prevented effectively by inserting the double sealed intermediate frame [2] between the plug/socket connector [1] and the housing of the device. The enclosure protection of the device (IP68) will not be affected, even if the electrical connection [1] is removed.

5.3.4. External earth connection

Figure 26: Earth connection for multi-turn actuator



Application External earth connection (U-bracket) for connection to equipotential compensation.

Table 15:

Terminal cross sections and earth connection tightening torques

Conductor type	Terminal cross sections	Tightening torques
Solid wire and stranded	2.5 mm ² to 6 mm ²	3 – 4 Nm
Fine stranded	1.5 mm ² to 4 mm ²	3 – 4 Nm

For fine stranded (flexible) wires, connection is made via cable lugs/ring terminals. When connecting two individual wires with a U-bracket, cross sections have to be identical.

6. Operation

6.1. Manual operation

For purposes of setting and commissioning, in case of motor or power failure, the actuator may be operated manually. Manual operation is engaged by an internal change-over mechanism.

6.1.1. Engage manual operation

NOTICE

Damage at the motor coupling due to faulty operation!

→ Engage manual operation only during motor standstill.

1. Press push button.

Figure 27: Engage manual operation

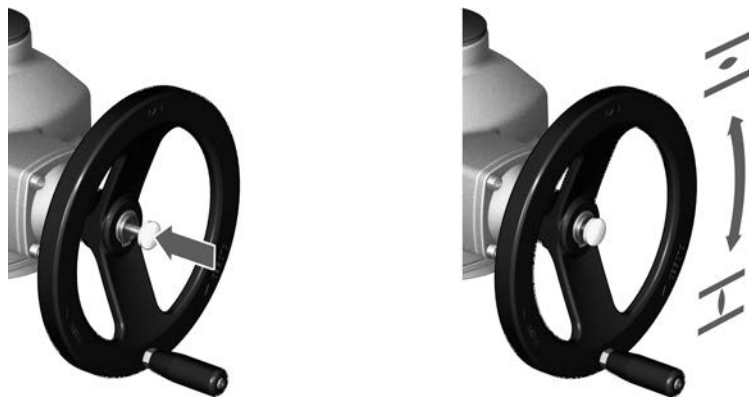

2. Turn handwheel in desired direction.

→ To close the valve, turn handwheel clockwise:

➔ Drive shaft (valve) turns clockwise in direction CLOSE.

Information

To protect the valve, an overload protection is available as option for manual operation. If the torque applied at the handwheel exceeds a certain value (refer to order-related technical data sheet), the shear pins will rupture and thus protect the valve from damage. The handwheel can no longer transmit the torque (= handwheel is spinning). Motor operation is still possible.

In case of shear pin rupture due to overload, we recommend replacing the safety hub.

Figure 28: Handwheel without/with overload protection



[1] Handwheel without overload protection (standard)

[2] Handwheel with overload protection/safety hub (option)

6.1.2. Manual operation: disengage

Manual operation is automatically disengaged when motor is started again. The handwheel does not rotate during motor operation.

6.2. Motor operation

Perform all commissioning settings and the test run prior to motor operation.

6.2.1. Local operation

The local operation of the actuator is performed using the push buttons of the local controls.

Figure 29: Local controls

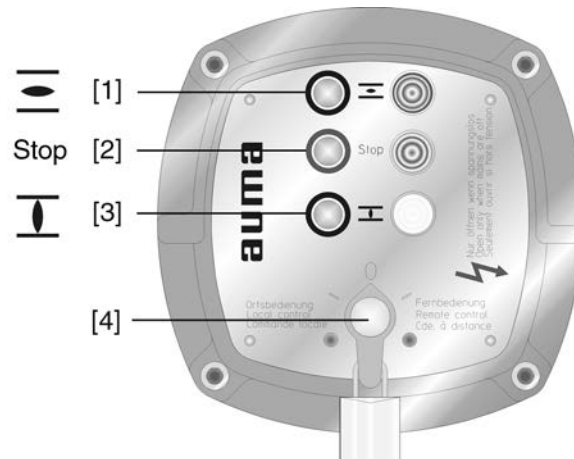

- [1] Push button for operation command in direction OPEN
- [2] Push button Stop
- [3] Push button for operation command in direction CLOSE
- [4] Selector switch



Hot surfaces, e.g. possibly caused by high ambient temperatures or strong direct sunlight!

Danger of burns

→ Verify surface temperature and wear protective gloves.

→ Set selector switch [4] to position **Local control** (LOCAL).



➔ The actuator can now be operated using the push buttons [1 – 3]:

- Run actuator in direction OPEN: Press push button [1]
- Stop actuator: Press push button [2] **Stop**.
- Run actuator in direction CLOSE: Press push button [3]

Information

The OPEN - CLOSE operation commands can be given either in push-to-run operation mode or in self-retaining mode. In self-retaining mode, the actuator runs to the defined end position after pressing the button, unless another command has been received beforehand.

6.2.2. Actuator operation from remote

→ Set selector switch to position **Remote control** (REMOTE).

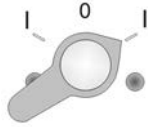

➔ Now, it is possible to operate the actuator via remote control, via operation commands (OPEN, STOP, CLOSE) or analogue setpoints (e.g. 0 – 20 mA).

Behaviour in modulating duty for version with positioner:

In case of signal loss of setpoint E1 or actual value E2, the actuator moves to a preset position. The following reactions are possible:

- **Fail as is:** Actuator stops immediately and remains in this position.
- **Fail close:** Actuator moves the valve to end position CLOSED.
- **Fail open:** Actuator moves the valve to end position OPEN.

The behaviour on loss of signal can be set via a switch in the controls.

7. Indications

7.1. Indication lights

Figure 30: Local controls with indication lights

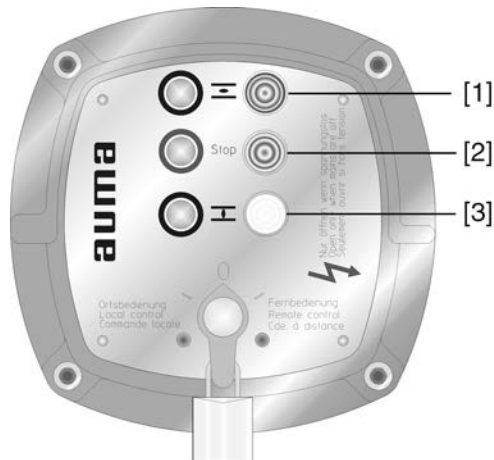

- [1] illuminated (default: green): End position OPEN reached
- [2] illuminated (default: red): Collective fault signal
- [3] illuminated (default: yellow): End position CLOSED reached

Information The three indication lights can be provided in different colours (deviating from the standard).

Collective fault signal The collective fault signal [2] appears if one of the following events occurs (default configuration):

- Torque fault: The set torque was exceeded before reaching an end position. (This signal can be activated/deactivated via a switch in the controls.)
- Thermal fault: Motor protection has tripped, i.e. the motor is overheated.
- Phase failure: One phase is missing (3-ph AC motors only).
- PTC tripping device: Test complete

Running indication If the actuator is equipped with a blinker transmitter (wiring diagram designation: S5), indication lights [1] and [3] can be used as running indication. The running indication can be activated/deactivated via a switch in the controls. If the running indication is active, the respective indication light blinks during operation.





7.2. Optional indications

7.2.1. Mechanical position indication via indicator mark

Figure 31: Mechanical position indicator



- [1] End position OPEN reached
- [2] End position CLOSED reached
- [3] Indicator mark at cover

- Characteristics**
- Independent of power supply
 - Used as running indication: Indicator disc rotates during actuator operation and continuously indicates the valve position
(For “clockwise closing version”, the symbols / rotate in counterclockwise direction for operation in direction CLOSE)
 - Indicates that end positions (OPEN/CLOSED) have been reached
(Symbols  (OPEN)/  (CLOSED) point to the indicator mark ▲ at cover)

8. Signals (output signals)

8.1. Status signals via output contacts (digital outputs)

The output contacts can be used to indicate operation modes of the actuator or the actuator controls as binary signals.

The signals are assigned according to the order. Example:

Output contact open = end position CLOSED not reached

Output contact closed = end position CLOSED reached

Collective fault signal Switches: 1 NC and 1 NO (standard)

Designation in the wiring diagram: K9

The collective fault signal appears if one of the following events occurs (default configuration):

- Torque fault: The set torque was exceeded before reaching an end position. (This signal can be activated/deactivated via a switch in the actuator controls.)
- Thermal fault: Motor protection has tripped, i.e. the motor is overheated.
- Phase failure: One phase is missing (3-ph AC motors only).
- PTC tripping device: Test complete

4 output contacts: Switches: 1 NC (standard)

Designation in the wiring diagram: K5, K6, K7, K8

Default configuration:

- K5: Selector switch is in position **Remote control** (REMOTE).
- K6: Selector switch is in position **Local control** (LOCAL).
- K7: End position OPEN reached (Limit switch OPEN operated)
- K8: End position CLOSED reached (Limit switch CLOSED operated)

8.2. Optional signals

8.2.1. Analogue signals (analogue outputs)

If the actuator is equipped with a position transmitter (EWG, RWG or potentiometer), an analogue position feedback signal is available.

Valve position Signal: E2 = 0/4 – 20 mA (galvanically isolated) with EWG or RWG

Designation in the wiring diagram: E2 (actual value)

9. Commissioning (basic settings)

1. Set selector switch to position **0** (OFF).



Information: The selector switch is not a mains switch. When positioned to **0** (OFF), the actuator cannot be operated. The controls' power supply is maintained.

2. Switch on the power supply.

Information: Please consider the heat-up time for ambient temperatures below $-40\text{ }^{\circ}\text{C}$.

3. Perform basic settings.

9.1. Heat-up time for low temperature version

Please note that for low temperature versions, the controls require a heat-up time.

This heat-up time applies if both actuators and actuator controls are not live and have cooled down to ambient temperature. Under these conditions and after connection to the voltage supply, the following heat-up times must be complied with prior to commissioning:

For $-40\text{ }^{\circ}\text{C}$ = 5 min.

For $-60\text{ }^{\circ}\text{C}$ = 40 min.

9.2. Switch compartment: open

The switch compartment must be opened to perform the following settings.

1. Loosen screws [2] and remove cover [1] from the switch compartment.

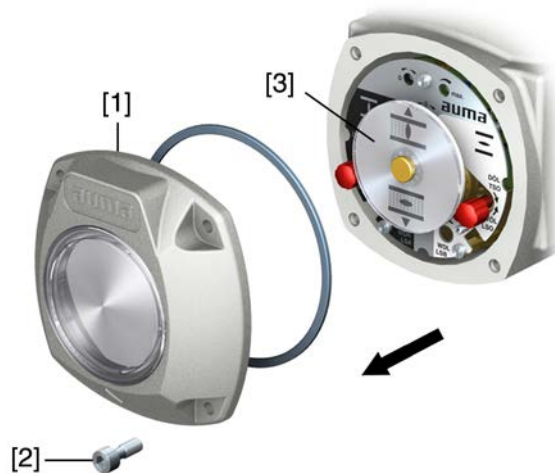

- If indicator disc [3] is available:

Remove indicator disc [3] using a spanner (as lever).

Information: To avoid damage to paint finish, use spanner in combination with soft object, e.g. fabric.



9.3. Torque switching: set

Once the set torque is reached, the torque switches will be tripped (overload protection of the valve).

Information The torque switches may also trip during manual operation.

NOTICE

Valve damage due to excessive tripping torque limit setting!

- The tripping torque must suit the valve.
- Only change the setting with the consent of the valve manufacturer.

Figure 32: Torque measuring heads

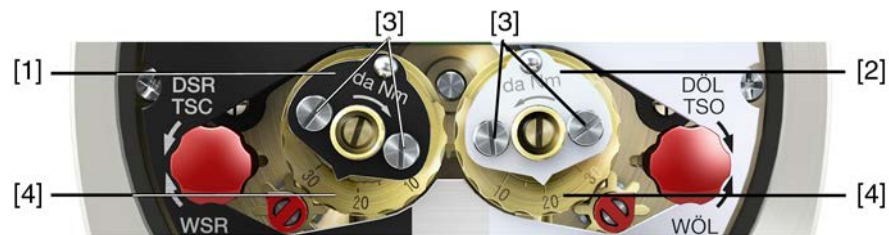

- [1] Torque switching head black in direction CLOSE
- [2] Torque switching head white in direction OPEN
- [3] Lock screws
- [4] Torque dials

- Loosen both lock screws [3] at the indicator disc.
- Turn torque dial [4] to set the required torque (1 da Nm = 10 Nm). Example:
 - Black torque switching head set to approx. 25 da Nm \pm 250 Nm for direction CLOSE
 - White torque switching head set to approx. 20 da Nm \pm 200 Nm for direction OPEN

- Fasten lock screws [3] again.

Information: Maximum tightening torque: 0.3 – 0.4 Nm

➔ The torque switch setting is complete.

9.4. Limit switching: set

The limit switching records the travel. When reaching the preset position, switches are operated.

Figure 33: Setting elements for limit switching



Black section:

- [1] Setting spindle: End position CLOSED
- [2] Pointer: End position CLOSED
- [3] Mark: End position CLOSED is set

White section:

- [4] Setting spindle: End position OPEN
- [5] Pointer: End position OPEN
- [6] Mark: End position OPEN is set

9.4.1. End position CLOSED (black section): set

1. Engage manual operation.
 2. Turn handwheel clockwise until valve is closed.
 3. Turn handwheel by approximately half a turn (overrun) in the opposite direction.
 4. **Press down** and turn setting spindle [1] with screw driver in direction of the arrow and observe the pointer [2]: While a ratchet click is felt and heard, the pointer [2] moves 90° every time.
 5. As soon as the pointer [2] is 90° from mark [3]: Continue turning slowly.
 6. As soon as the pointer [2] moves to mark [3]: Stop turning and release setting spindle.
- ➔ The end position CLOSED setting is complete.
7. If you override the tripping point inadvertently (ratchet click is heard after the pointer has snapped): Continue turning the setting spindle in the same direction and repeat setting process.

9.4.2. End position OPEN (white section): set

1. Engage manual operation.
 2. Turn handwheel counterclockwise until valve is open.
 3. Turn handwheel by approximately half a turn (overrun) in the opposite direction.
 4. **Press down** and turn setting spindle [4] with screw driver in direction of the arrow and observe the pointer [5]: While a ratchet click is felt and heard, the pointer [5] moves 90° every time.
 5. As soon as the pointer [5] is 90° from mark [6]: Continue turning slowly.
 6. As soon as the pointer [5] moves to mark [6]: Stop turning and release setting spindle.
- ➔ The end position OPEN setting is complete.
7. If you override the tripping point inadvertently (ratchet click is heard after the pointer has snapped): Continue turning the setting spindle in the same direction and repeat setting process.

9.5. Intermediate positions: set

Actuators equipped with DUO limit switching contain two intermediate position switches. One intermediate position may be set for each running direction.

Figure 34: Setting elements for limit switching



Black section:

- [1] Setting spindle: Running direction CLOSE
- [2] Pointer: Running direction CLOSE
- [3] Mark: Intermediate position CLOSED is set

White section:

- [4] Setting spindle: Running direction OPEN
- [5] Pointer: Running direction OPEN
- [6] Mark: Intermediate position OPEN is set

Information After 177 turns (control unit for 2 – 500 turns/stroke) or 1,769 turns (control unit for 2 – 5,000 turns/stroke), the intermediate switches release the contact.

9.5.1. Running direction CLOSE (black section): set

1. Move valve in direction CLOSE to desired intermediate position.
2. If you override the tripping point inadvertently: Turn valve into the opposite direction and approach intermediate position again in direction CLOSE.
Information: Always approach the intermediate position in the same direction as in later electrical operation.
3. **Press down** and turn setting spindle [1] with screw driver in direction of the arrow and observe the pointer [2]: While a ratchet click is felt and heard, the pointer [2] moves 90° every time.
4. As soon as the pointer [2] is 90° from mark [3]: Continue turning slowly.
5. As soon as the pointer [2] moves to mark [3]: Stop turning and release setting spindle.
- ➔ The intermediate position setting in running direction CLOSE is complete.
6. If you override the tripping point inadvertently (ratchet click is heard after the pointer has snapped): Continue turning the setting spindle in the same direction and repeat setting process.

9.5.2. Running direction OPEN (white section): set

1. Move valve in direction OPEN to desired intermediate position.
2. If you override the tripping point inadvertently: Move valve in opposite direction and approach intermediate position again in direction OPEN (always approach the intermediate position in the same direction as in later electrical operation).

3. **Press down** and turn setting spindle [4] with screw driver in direction of the arrow and observe the pointer [5]: While a ratchet click is felt and heard, the pointer [5] moves 90° every time.
 4. As soon as the pointer [5] is 90° from mark [6]: Continue turning slowly.
 5. As soon as the pointer [5] moves to mark [6]: Stop turning and release setting spindle.
- ➔ The intermediate position setting in running direction OPEN is complete.
6. If you override the tripping point inadvertently (ratchet click is heard after the pointer has snapped): Continue turning the setting spindle in the same direction and repeat setting process.

9.6. Test run

Only perform test run only once all settings previously described have been performed.

9.6.1. Direction of rotation at mechanical position indicator: check

NOTICE

Valve damage due to incorrect direction of rotation!

- If the direction of rotation is wrong, switch off immediately (press STOP).
- Eliminate cause, i.e. correct phase sequence for cable set wall bracket.
- Repeat test run.

Information

Switch off before reaching the end position.

1. Move actuator manually to intermediate position or to sufficient distance from end position.
2. Switch on actuator in direction CLOSE and observe the direction of rotation on the mechanical position indication:

→ **For mechanical position indication via indicator mark:** (not self-adjusting)

➔ The direction of rotation is correct if the actuator operation in direction **CLOSE** and the symbols $\overline{\ominus}/\overline{\uparrow}$ turn **counterclockwise**:

Figure 35: Direction of rotation $\overline{\ominus}/\overline{\uparrow}$ (for “clockwise closing version”)



9.6.2. Direction of rotation at hollow shaft/stem: check

NOTICE

Valve damage due to incorrect direction of rotation!

- If the direction of rotation is wrong, switch off immediately (press STOP).
- Eliminate cause, i.e. correct phase sequence for cable set wall bracket.
- Repeat test run.

Information

Switch off before reaching the end position.

1. Move actuator manually to intermediate position or to sufficient distance from end position.
 2. Unscrew threaded plug [1] and seal [2] or protective cap for stem protection tube [4].
 3. Switch on actuator in direction CLOSE and observe direction of rotation at hollow shaft [3] or stem [5]:
 - ➔ The direction of rotation is correct if the actuator moves in direction **CLOSE** and the hollow shaft in **clockwise** direction, or the stem moves downward.
- Figure 36: Hollow shaft/stem movement (for “clockwise closing”)

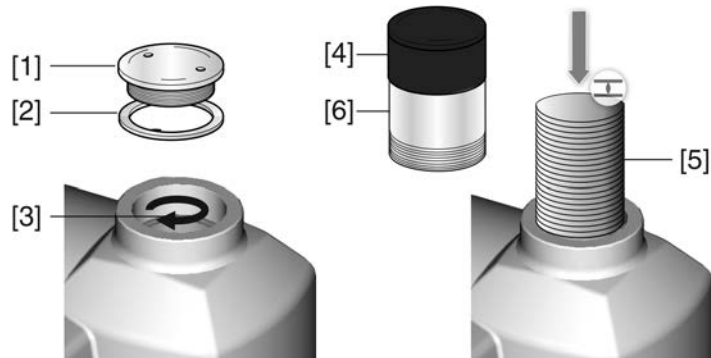

- [1] Threaded plug
- [2] Seal
- [3] Hollow shaft
- [4] Protective cap for stem protection tube
- [5] Stem
- [6] Stem protection tube

4. Correctly fit/screw on threaded plug [1] and seal [2] or protective cap for stem protection tube [4], fasten thread.

9.6.3. Limit switching: check

1. Set selector switch to position **Local control** (LOCAL).



2. Operate actuator using push buttons OPEN, STOP, CLOSE.
 - ➔ The limit switching is set correctly if (default indication):
 - the yellow indication light is illuminated in end position CLOSED
 - the green indication light is illuminated in end position OPEN
 - the indication lights go out after travelling into the opposite direction.
 - ➔ The limit switching is set incorrectly if:
 - the actuator comes to a standstill before reaching the end position
 - the red indication light is illuminated (torque fault).
3. If the end position setting is incorrect: Reset limit switching.
4. If the end position setting is correct and no options (e.g. potentiometer, position transmitter) are available: Close switch compartment.

9.6.4. PTC tripping device (option): test

1. Turn selector switch to position **Test** (spring return).

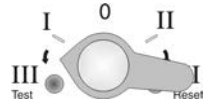

- ➔ If the PTC tripping device is working properly, the tripping of the motor protection is signalled via the red "collective fault signal" indication light on the local controls.

2. Turn selector switch to position **Reset**.

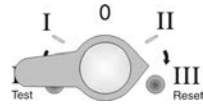

- ➔ The fault signal is reset if the device is working properly.
3. If no fault signal is initiated: Request AUMA Service for inspection of actuator controls

9.7. Switch compartment: close

- ✓ If options (e.g. potentiometer, position transmitter) are available: Only close switch compartment once all optional equipment has been successfully set.

NOTICE

Danger of corrosion due to damage to paint finish!

→ Touch up damage to paint finish after work on the device.

1. Clean sealing faces of housing and cover.
2. Check whether O-ring [3] is in good condition, replace if damaged.
3. Apply a thin film of non-acidic grease (e.g. petroleum jelly) to the O-ring and insert it correctly.

Figure 37:



4. Place cover [1] on switch compartment.
5. Fasten screws [2] evenly crosswise.

10. Commissioning (optional equipment settings)

10.1. EWG 01.1 electronic position transmitter

EWG 01.1 electronic position transmitter signals the remote position or the valve position. On the basis of the actual valve position sensed by hall sensor, a current signal between 0 – 20 mA or 4 – 20 mA is generated.

Technical data

Table 16: EWG 01.1

Data	3-wire and 4-wire systems	2-wire system
Output current I_a	0 – 20 mA, 4 – 20 mA	4 – 20 mA
Power supply $U_V^{1)}$	24 V DC (18 – 32 V)	24 V DC (18 – 32 V)
Max. current consumption	LED off = 26 mA, LED on = 27 mA	20 mA
Max. load R_B	600 Ω	$(U_V - 12 V)/20 mA$
Impact of power supply		0.1 %
Load influence		0.1 %
Temperature impact		< 0.1 %/K
Ambient temperature ²⁾		-60 °C to +80 °C

- 1) Power supply possible via: AC, AM actuator controls or external power supply
2) Depending on temperature range of the actuator: Refer to name plate

Setting elements

The EWG is housed in the actuator switch compartment. The switch compartment must be opened to perform any settings. Refer to <Switch compartment: open>.

All settings are made via the two push buttons [S1] and [S2].

Figure 38: View on control unit when switch compartment is open



- [S1] Push button: Set 0/4 mA
[S2] Push button: Set 20 mA
LED Optical aid for setting
[1] Measuring point (+) 0/4 – 20 mA
[2] Measuring point (-) 0/4 – 20 mA

The output current (measuring range 0 – 20 mA) can be checked at measuring points [1] and [2].

Table 17:

Short overview on push button functions	
Push buttons	Function
[S1] + [S2]	→ press simultaneously for 5 s: Activate setting mode
[S1]	→ press in setting mode for 3 s: Set 4 mA → press in setting mode for 6 s: Set 0 mA → press in operation for 3 s: Switch on/off LED end position signalling. → touch in end position: Reduce current value by 0.02 mA
[S2]	→ press in setting mode for 3 s: Set 20 mA → press in operation for 3 s: Switch on/off LED end position signalling. → touch in end position: Increase current value by 0.02 mA

10.1.1. Measuring range: set

For measuring range setting, voltage must be applied at the position transmitter.

For output current verification, connect a test device for 0 – 20 mA to measurement points (+/-) (for 2-wire systems, connecting a test device is imperatively required).

Information

- Both measuring ranges 0/4 – 20 mA and 20 – 0/4 mA (inverse operation) can be set.
 During setting process, the measuring range (normal or inverse operation) is assigned to the end positions by push button S1/S2 assignment.
- For 2-wire systems, switch off <LED end position signalling> prior to setting the measuring range.
- Setting mode activation clears the settings in both end positions and sets the output current to a value of 3.5 mA. After activation, both end values (0/4 mA and 20 mA) need to be reset.
- In case of inadvertent incorrect adjustment, the settings can always be reset by renewed activation of the setting mode (simultaneous pressing of [S1] and [S2]).

Activate setting mode

1. Press both push buttons [S1] and [S2] and hold down for 5 seconds:

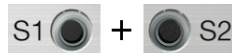



- ➔ By pulsing double flashes, the LED indicates that the setting mode is correctly activated:



- ➔ For any other LED flash sequence (single/triple flashing): Refer to <Faults during commissioning>.

Set measuring range

2. Operate valve in one of the end positions (OPEN/CLOSED).
3. Set desired output current (0/4 mA or 20 mA):
 - ➔ for **4 mA**: Hold down push button [S1] for approx. 3 seconds, until **LED is blinking slowly** .
 - ➔ for **0 mA**: Hold down push button [S1] for approx. 6 seconds, until **LED is blinking fast** .
 - ➔ for **20 mA**: Hold down push button [S2] for approx. 3 seconds, until **LED is illuminated** .

Information: For 2-wire systems read current values at test device.

4. Operate valve into opposite end position.
 - ➔ The value set in end position (0/4 mA or 20 mA) does not change during travel in setting mode.
5. Perform setting in the second end position following the same steps.
6. Approach both end positions again to check the setting.
 - ➔ If the measuring range cannot be set:
 Refer to <Faults during commissioning>.
 - ➔ If the current values (0/4/20 mA) are incorrect:
 Refer to <Current values: adjust>.
 - ➔ If the current value fluctuates (e.g. Between 4.0 – 4.2 mA):
 Switch off LED end position signalling.
 Refer to <LED end position signalling: switch on/off>.

10.1.2. Current values : adjust

The current values (0/4/20 mA) set in end positions can be adjusted at any time. Common values are e.g. 0.1 mA (instead of 0 mA) or 4.1 mA (instead 4 mA).



- Information** If the current value fluctuates (e.g. between 4.0 – 4.2mA), the <LED end position signalling> must be switched off for current adjustment.
- Operate valve in desired end position (OPEN/CLOSED).
 - Reduce current value: Press push button [S1] (the current is reduced by 0.02 mA every time the push button is pressed)
 - Increase current value: Press push button [S2] (the current is increased by 0.02 mA every time the push button is pressed)

10.1.3. LED end position signalling: switch on/off

The LED behaviour for end position reached can be set as follows: blinking/continuous illumination or no illumination. During setting mode, end position signalling is switched on.

- Switching on and off**
1. Operate valve in one of the end positions (OPEN/CLOSED).
 2. Hold down push buttons [S1] or [S2] for approx. 3 seconds.
- ➔ End position signalling is switched on or off.

Table 18:

LED behaviour when end position signalling is switched on	
Set output current	LED behaviour in end position
4 mA	 LED is blinking slowly
0 mA	 LED is blinking fast
20 mA	 LED is illuminated

10.2. Potentiometer

- Setting elements** The potentiometer is used as travel sensor and records the valve position. The potentiometer is housed in the actuator switch compartment. The switch compartment must be opened to perform any settings. Refer to <Switch compartment: open>.

Setting is made via potentiometer [1].

Figure 39: View on control unit



[1] Potentiometer

10.2.1. Potentiometer: set

- Information** Due to the ratio of the reduction gearing, the complete resistance range/stroke is not always covered. Therefore, external adjustment (setting potentiometer) must be provided.

1. Move valve to end position CLOSED.

2. Turn potentiometer [1] clockwise to the stop.
 - ➔ End position CLOSED corresponds to 0 %
 - ➔ End position OPEN corresponds to 100 %
3. Turn potentiometer [1] slightly in opposite direction.
4. Perform fine-tuning of the zero point at external setting potentiometer (for remote indication).

10.3. RWG electronic position transmitter

The RWG electronic position transmitter records the valve position. On the basis of the actual position value measured by the potentiometer (travel sensor), it generates a current signal between 0 – 20 mA or 4 – 20 mA.

Technical data

Table 19: RWG 4020

Data	3-wire and 4-wire systems	2-wire system
Output current I_a	0 – 20 mA, 4 – 20 mA	4 – 20 mA
Power supply U_V ¹⁾	24 V DC (18 – 32 V)	14 V DC + (I x R _B), max. 30 V
Max. current consumption	24 mA at 20 mA output current	20 mA
Max. load R _B	600 Ω	(U _V – 14 V)/20 mA
Impact of power supply	0.1 %/V	0.1 %/V
Load influence	0.1 %/(0 – 600 Ω)	0.1 %/100 Ω
Temperature impact	< 0.3 %/K	
Ambient temperature ²⁾	–60 °C to +80 °C	
Transmitter potentiometer	5 kΩ	

- 1) Power supply possible via: AC, AM actuator controls or external power supply
- 2) Depending on temperature range of the actuator: Refer to name plate

Setting elements

The RWG is housed in the actuator switch compartment. The switch compartment must be opened to perform any settings. Refer to <Switch compartment: open>.

Setting is made via three potentiometers [1], [2] and [3].

Figure 40: View on control unit when switch compartment is open



- [1] Potentiometer (travel sensor)
- [2] Potentiometer min. (0/4 mA)
- [3] Potentiometer max. (20 mA)
- [4] Measuring point (+) 0/4 – 20 mA
- [5] Measuring point (–) 0/4 – 20 mA

The output current (measuring range 0 – 20 mA) can be checked at measuring points [4] and [5].

10.3.1. Measuring range: set

For measuring range setting, voltage must be applied at the position transmitter.

1. Move valve to end position CLOSED.

2. Connect ammeter for 0 – 20 mA to measuring points [4 and 5].
3. Turn potentiometer [1] clockwise to the stop.
4. Turn potentiometer [1] slightly in opposite direction.
5. Turn potentiometer [2] clockwise until output current starts to increase.
6. Turn potentiometer [2] in opposite direction until the following value is reached:
 - for 0 – 20 mA approx. 0.1 mA
 - for 4 – 20 mA approx. 4.1 mA
- ➔ This ensures that the signal remains above the dead and live zero point.
7. Move valve to end position OPEN.
8. Set potentiometer [3] to end value 20 mA.
9. Approach end position CLOSED again and check minimum value (0.1 mA or 4.1 mA). If necessary, correct the setting.

Information If the maximum value cannot be reached, the selection of the reduction gearing must be checked.

10.4. Mechanical position indicator: set

1. Fit indicator disc onto shaft.
2. Move valve to end position CLOSED.
3. Turn lower indicator disc until symbol  (CLOSED) is in alignment with the ▲ mark on the cover.



4. Move actuator to end position OPEN.
5. Hold lower indicator disc in position and turn upper disc with symbol  (OPEN) until it is in alignment with the ▲ mark on the cover.



6. Move valve to end position CLOSED again.
7. Check settings:
 - If the symbol  (CLOSED) is no longer in alignment with ▲ mark on the cover:
 - 7.1 Repeat setting procedure.
 - 7.2 Check whether the appropriate reduction gearing has been selected, if required.

11. Commissioning – controls settings

The controls are set in the factory according to the order. The settings only have to be changed if the device is used for applications other than those specified in the order. In case the device is equipped with a positioner (option), subsequent setting may be required.

The following settings are described in these operation instructions:

- Type of seating (limit or torque seating): set
- Push-to-run operation or self-retaining: set
- Running indication (blinker transmitter) (option): activate/deactivate
- Torque fault in collective fault signal: activate/deactivate
- Positioner setting (option)

11.1. Actuator controls: open

DANGER

Hazardous voltage!

Risk of electric shock.

→ Disconnect device from the mains before opening.

NOTICE

Electrostatic discharge ESD!

Risk of damage to electronic components.

→ Earth both operators and devices.

→ Loosen screws [2] and remove cover [1].

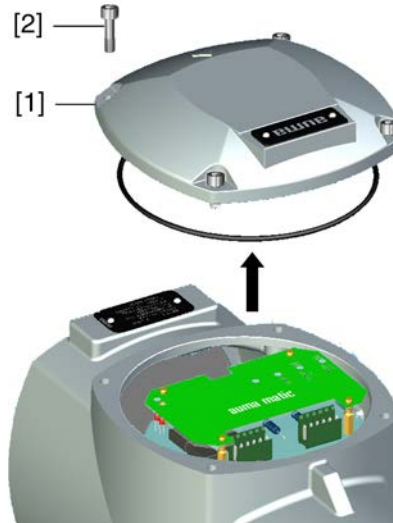

11.2. Type of seating: set

NOTICE

Valve damage due to incorrect setting!

→ The type of seating must suit the valve.

→ Only change the setting with the consent of the valve manufacturer.

The type of seating can be set via two DIP switches on the logic board.

Limit seating

The limit switching is set in such a way that the actuator switches off at the desired switching points. The torque switching acts as overload protection for the valve.

Torque seating

The torque switching is set to the desired tripping torque. After reaching the tripping torque, the actuator is turned off.

The limit seating is used to signal that the limit switching will trip shortly **before** reaching the set tripping torque. If this is not the case, either the indication light on the local controls or the alarm contact K9 (collective fault signal) will signal a fault.

→ Set type of seating for end positions via DIP switches [S1] and [S3].

Figure 41: DIP switches on logic board

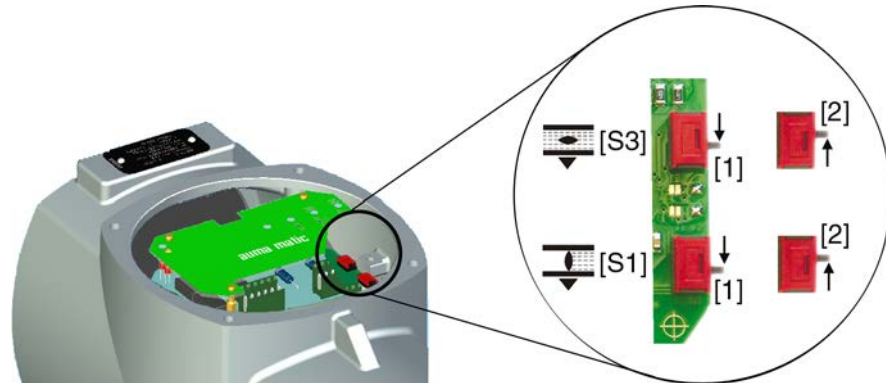

- [S1] DIP switch for end position CLOSED
- [S3] DIP switch for end position OPEN
- [1] Position [1] = limit seating
- [2] Position [2] = torque seating

11.3. Push-to-run operation or self-retaining: set

Push-to-run operation or self-retaining is set via a DIP switch on the logic board.

Push-to-run operation Actuator only runs in direction OPEN or CLOSE while an operation command is being received. The actuator stops if the operation command is cancelled.

Self-retaining After receiving an operation command, the actuator continues to run in direction OPEN or CLOSE, even if the operation command is cancelled (self-retaining). The actuator is either stopped by the STOP command or if an end position or intermediate position has been reached.

→ Set push-to-run operation or self-retaining via DIP switch [S2].

Figure 42: DIP switch on logic board

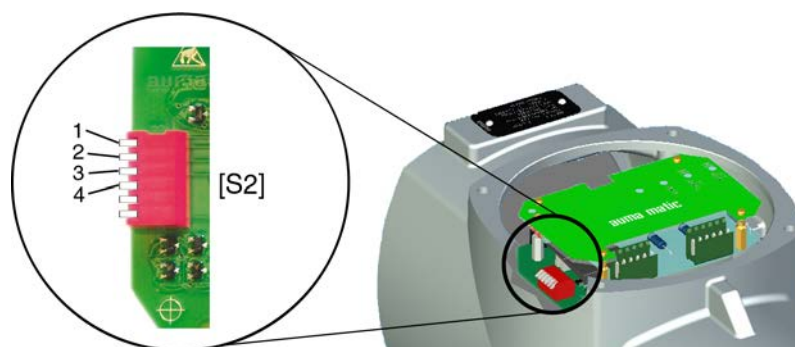

- [S2] 6-way DIP, switches [1 – 4]:
 - 1 for operation commands CLOSE from remote
 - 2 for operation commands OPEN from remote
 - 3 for operation commands CLOSE via push button at local controls
 - 4 for operation commands OPEN via push button at local controls

- Switch in lower position (position ON): Self-retaining
- Switch in upper position (position OFF): Push-to-run operation

Information If the controls are equipped with a positioner, switches 1 and 2 (operation commands from remote) must be in position OFF (push-to-run operation).

11.4. Running indication (blinker transmitter): activate/deactivate

— (Option) —

If the actuator is equipped with a blinker transmitter (wiring diagram designation: S5), indication lights (OPEN/CLOSE) on the local controls can be used as running indication. If the running indication is active, the respective indication light blinks during actuator operation.

The running indication is activated/deactivated via a DIP switch on the logic board.

→ Set running indication (blinker) via DIP switch [S2].

Figure 43: DIP switch on logic board

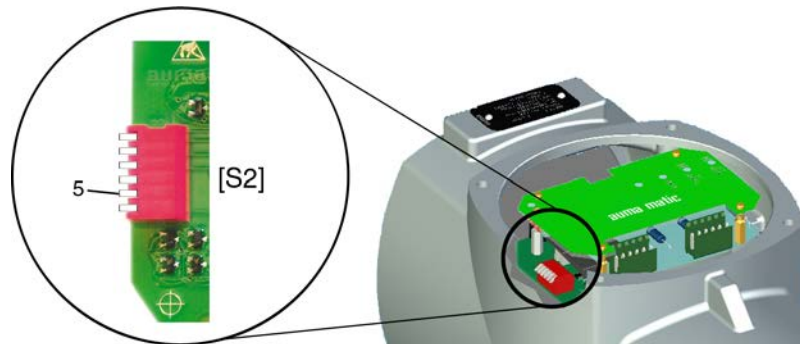

[S2] 6-way DIP, switch 5

- ➔ Switch 5 in lower position (position ON): Running indication is deactivated.
- ➔ Switch 5 in upper position (position OFF): Running indication is activated.

11.5. Torque fault in collective fault signal: activate/deactivate

The torque fault signal is activated/deactivated via a DIP switch on the logic board.

→ Activate/deactivate signal via DIP switch [S2].

Figure 44: DIP switch on logic board

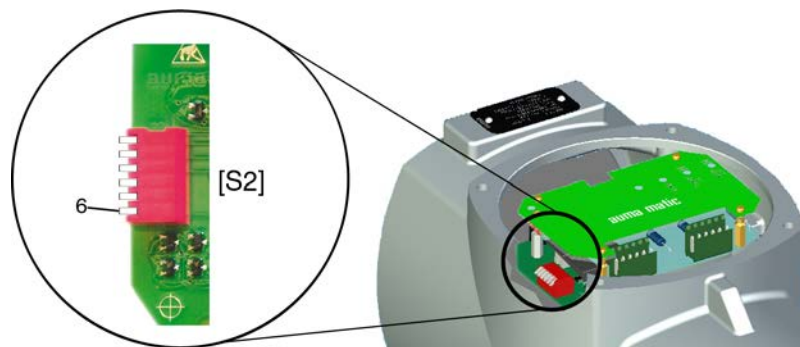

[S2] 6-way DIP, switch 6

- ➔ Switch 6 in lower position (position ON): The signal "Torque fault in collective fault signal" is activated.
- ➔ Switch 6 in upper position (position OFF): The signal "Torque fault in collective fault signal" is deactivated.

11.6. LEDs for torque fault, phase failure, motor protection

The interface board is equipped with two LEDs for indicating the torque fault, phase failure and motor protection (thermal fault) fault signals

Figure 45: LEDs on interface board

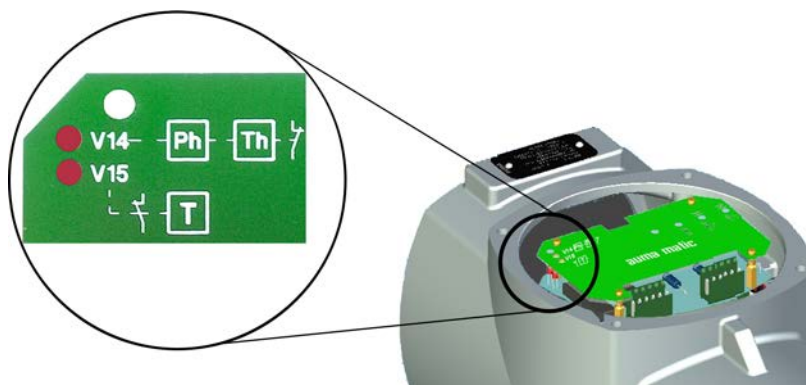

[V14] illuminated: Phase failure (Ph) and/or motor protection (Th) tripped
[V15] illuminated: Torque fault (T), tripping torque reached in mid-travel.

11.7. Positioner

— (Option) —

→ Prior to positioner setting, set limit and torque switching as well as potentiometer or electronic position transmitter.

11.7.1. Input ranges (signal type) for setpoint and actual value

The input range (signal type) for setpoint E1 and actual value E2 is set in the factory and marked with a label on the cover plate of the positioner.

The type of signal can be modified at a later date exclusively for versions with setpoint E1 ≠ 0/4 – 20 mA and split-range version. For these versions, the positioner board is equipped with an additional contact.

Figure 46: Version with additional switch on the positioner board

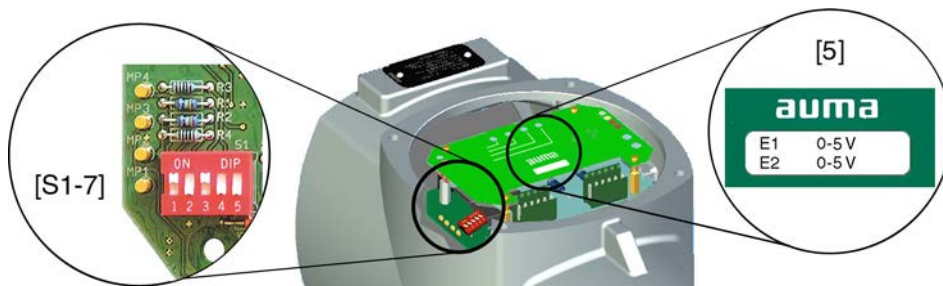

[5] Label indicating the set input ranges
[S1-7] 5-contact DIP switch for setting
DIP1 Actual value E2 (current or voltage signal)
DIP3 Setpoint E1 (current or voltage signal)
DIP5 Setpoint E1 (double signal range e.g. for split range)

Table 20: Input range setting for setpoint E1

Setpoint E1	[S1-7]
	DIP 3 and 5
0/4 – 20 mA	ON
0 – 5 V	ON
0 – 10 V	ON

Table 21: Input range setting for actual value E2

Actual value E2	[S1-7]				
	DIP 1				
0/4 – 20 mA ¹⁾	ON	<input type="checkbox"/>	<input type="checkbox"/>	<input type="checkbox"/>	<input type="checkbox"/>
0 – 5 V ²⁾	ON	<input type="checkbox"/>	<input type="checkbox"/>	<input type="checkbox"/>	<input type="checkbox"/>

- 1) for internal feedback of RWG electronic position transmitter
- 2) for internal feedback of precision potentiometer 5 kΩ

Information When changing the setting, a new label [5] indicating the set signal type must be provided. Furthermore, the wiring diagram indicated on the name plate of the actuator controls also changes.

11.7.2. Behaviour on loss of signal (actuator reaction)

In case of a loss of signal of setpoint E1 or actual value E2, the reaction of the actuator can be programmed via switch [S2-7]. The complete selection range, however, is only available for signals 4 – 20 mA.

The following reactions are possible:

- Fail as is:** Actuator stops immediately and remains in this position.
- Fail close:** Actuator moves the valve to end position CLOSED.
- Fail open:** Actuator moves the valve to end position OPEN.

Figure 47: DIP switch [S2-7] on positioner board

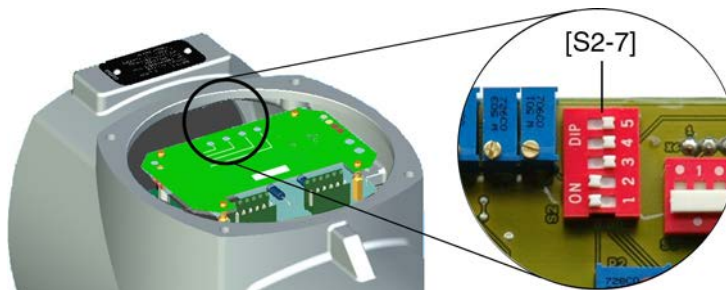







- DIP1 = ON, actual value E2 is monitored
- DIP2 = ON, setpoint E1 is monitored

Table 22: Recommended settings

Behaviour on loss of signal of E1 and/or E2	Signal type		[S2-7]				
	Setpoint E1	Actual value E2	DIP 1	2	3	4	
Fail as is	4 – 20 mA	4 – 20 mA	ON	<input type="checkbox"/>	<input type="checkbox"/>	<input type="checkbox"/>	<input type="checkbox"/>
Fail close			ON	<input type="checkbox"/>	<input type="checkbox"/>	<input type="checkbox"/>	<input type="checkbox"/>
Fail open			ON	<input type="checkbox"/>	<input type="checkbox"/>	<input type="checkbox"/>	<input type="checkbox"/>

Table 23: Further possible settings

Behaviour on loss of signal of		Signal type ¹⁾		[S2-7]
E1	E2	Setpoint E1	Actual value E2	DIP 1 2 3 4
Fail as is	Fail open	4 – 20 mA	0 – 5 V	ON 
Fail close	Fail open	4 – 20 mA	0 – 5 V	ON 
		0 – 20 mA	4 – 20 mA	ON 
		0 – 20 mA 0 – 5 V 0 – 10 V	0 – 20 mA 0 – 5 V	ON 
	Fail close	0 – 20 mA 0 – 5 V	4 – 20 mA	ON 
	Fail as is	0 – 20 mA 0 – 10 V	4 – 20 mA	ON 
Fail open		4 – 20 mA	0 – 20 mA 0 – 5 V	ON 

1) in case of a signal loss, a misinterpretation might be made for 0 – 20 mA, 0 – 5 V or 0 – 10 V, due to the fact that E1 or E2 could take the value 0 mA even without loss of signal (end position CLOSED = 0 mA or 0 V).

11.7.3. Adjustment in end positions

The setting described below applies to the standard positioner version, i.e. maximum setpoint E1 (20 mA) triggers a travel to end position OPEN, minimum setpoint (0/4 mA) triggers a travel to end position CLOSED.

Figure 48: Electronic positioner board

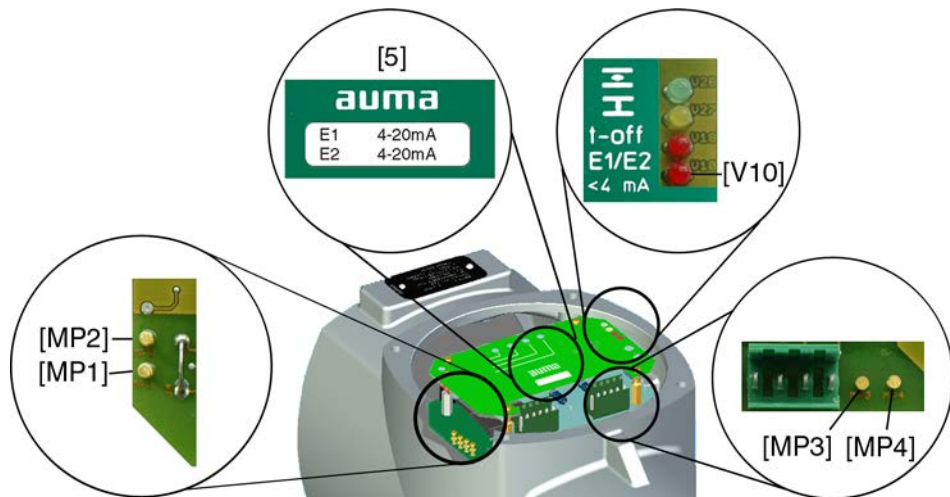

- [MP1] Measuring point (–) for actual value E2
- [MP2] Measuring point (+) for actual value E2
- [MP3] Measuring point (+) for setpoint E1
- [MP4] Measuring point (–) for setpoint E1
- [5] Label with signal indication
- [V10] Red LED: E1/E2 < 4 mA

- End position CLOSED**
1. Set selector switch to position **Local control** (LOCAL).
 2. Move valve to end position CLOSED.

3. Connect lower setpoint to customer connection XK (terminals 2/3). The lower setpoint (0 V, 0 mA or 4 mA) is indicated on the label [5].
4. If the red LED [V10] **E1/E2 <4 mA** is illuminated:
 - 4.1 Verify polarity of setpoint E1.
 - 4.2 Check whether external load is connected to customer connection XK (terminals 23/24) (observe max. load R_B), or
 - 4.3 Connect terminals 23/24 across customer connection XK (terminals 23/24).
5. Measure setpoint E1: Connect measuring device for 0 – 5 V to measuring points **[MP3/MP4]**.
 - ➔ For a setpoint E1 of 0 V or 0 mA, the voltmeter shows 0 V.
 - ➔ For a setpoint E1 of 4 mA, the voltmeter shows 1 V.
6. If measured value is not correct: Correct setpoint E1.
7. Measure actual value E2: Connect measuring device for 0 – 5 V to measuring points **[MP1/MP2]**.
 - ➔ For an actual value E2 of 0 mA, the voltmeter shows 0 V.
 - ➔ For an actual value E2 of 4 mA, the voltmeter shows 1 V.
8. If measured value is not correct: Re-set potentiometer or electronic position transmitter and perform adjustment once again, starting from step 1.
9. Adjust positioner using potentiometer **0** [P3].
 - 9.1 If both LEDs are OFF or the green LED [V28] is illuminated: Turn potentiometer **0** [P3] slightly clockwise until the yellow LED [V27] is illuminated.
 - 9.2 If the yellow LED [V27] is illuminated: Turn potentiometer **0** [P3] counter-clockwise until the yellow LED [V27] goes out. Then turn potentiometer **0** [P3] slightly clockwise until the yellow LED [V27] is illuminated again.

Figure 49: Electronic positioner board

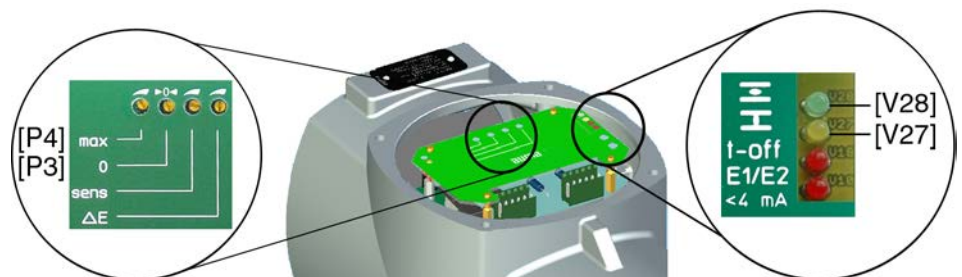

- [P3] Potentiometer 0
- [P4] Potentiometer max
- [V27] Yellow LED: End position CLOSED reached
- [V28] Green LED: End position OPEN reached

- ➔ The setting is correct if the yellow LED [V27] is switched on when reaching end position CLOSED.

End position OPEN

10. Move valve to end position OPEN.
11. Measure actual value E2 (measuring points **[MP1/MP2]**):
 - ➔ For an actual value E2 of 20 mA, the voltmeter shows 5 V.
12. If measured value is not correct: Re-set potentiometer or electronic position transmitter and perform adjustment once again, starting from step 1.
13. Set maximum setpoint E1 (5 V or 20 mA, refer to label [5]).
14. Measure setpoint E1 (measuring points **[MP3/MP4]**):
 - ➔ For a setpoint E1 of 5 V or 20 mA, the voltmeter shows 5 V.
15. If measured value is not correct: Verify setpoint E1.

16. Adjust positioner using potentiometer **max** [P4].
 - 16.1 If both LEDs are OFF or the yellow LED [V27] is illuminated: Turn potentiometer **max** [P4] slightly counterclockwise until the green LED [V28] is illuminated.
 - 16.2 If the green LED [V28] is illuminated: Turn potentiometer **max** [P4] clockwise until the green LED [V28] goes out. Then turn potentiometer **0** [P3] slightly counterclockwise until the green LED [V28] is illuminated again.
 - ➔ The setting is correct if the green LED [V28] is switched on when reaching end position OPEN.

11.7.4. Sensitivity setting

NOTICE

Unnecessary wear at valve and actuator caused by an excessive number of starts (sensitivity)!

- Set maximum dead band acceptable for the process.
- Observe maximum number of actuator starts (refer to technical data sheet for modulating actuators).

Dead band The dead band determines the sensitivity between switch-on point and switch-off point. The smaller the dead band, the higher the sensitivity of the positioner.

Default value: 2.5 %

Setting range: 0.5 % to 2.5 % (of the maximum setpoint E1)

Dead time The dead time prevents the operation to a new setpoint within a pre-determined time (0.5 to 10 seconds). The number of starts can be reduced by setting the dead time to a sufficiently high value.

Figure 50: Sensitivity setting

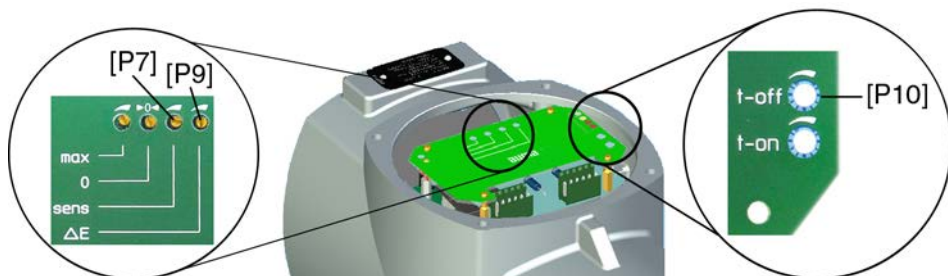

[P7] Potentiometer **sens** (fine tuning)

[P9] Potentiometer **ΔE** (dead band)

[P10] Potentiometer **t-off** (dead time)

- Dead band setting**
1. Set selector switch to position **Remote control** (REMOTE).
 2. Connect setpoint E1 to customer connection XK (terminals 2/3).
 3. Set dead band using potentiometer **ΔE** [P9]:
 - Reduce dead band (increase sensitivity): Turn potentiometer counterclockwise.
 - Increase dead band (reduce sensitivity): Turn potentiometer clockwise.
- Fine tuning**
- Information:** Fine tuning is only useful for output speeds <16 rpm. For 1-phase AC motors, fine tuning is not possible.
4. Reduce dead band further by up to 0.25 % (increase sensitivity): Turn potentiometer **sens** [P7] counterclockwise.

- Dead time setting**
5. Set dead time using potentiometer **t-off** [P10]:
 - Reduce dead time: Turn potentiometer **t-off** [P10] counterclockwise.
 - Increase dead time: Turn potentiometer **t-off** [P10] clockwise.

11.8. EMERGENCY command (EMERGENCY - OPEN/EMERGENCY - CLOSE)

— (Option) —

The EMERGENCY input (refer to wiring diagram) has to be connected to the control voltage using an NC contact (closed circuit principle). In the event of an EMERGENCY command (removal of the signal = NC contact is operated), the actuator runs to the preset end position:

- EMERGENCY - CLOSE input: Actuator runs to end position CLOSED.
- EMERGENCY - OPEN input: Actuator runs to end position OPEN.

The EMERGENCY command is effective in all three selector switch positions (LOCAL, OFF, REMOTE).



The actuator can immediately start when switched on!

Risk of personal injuries or damage to the valve.

- Ensure that EMERGENCY signal is present when switching on.
- If the actuator starts to run unexpectedly: Immediately press push button **Stop**.

Disable EMERGENCY command

Figure 51: Interface board for available option EMERGENCY - OPEN/EMERGENCY - CLOSE

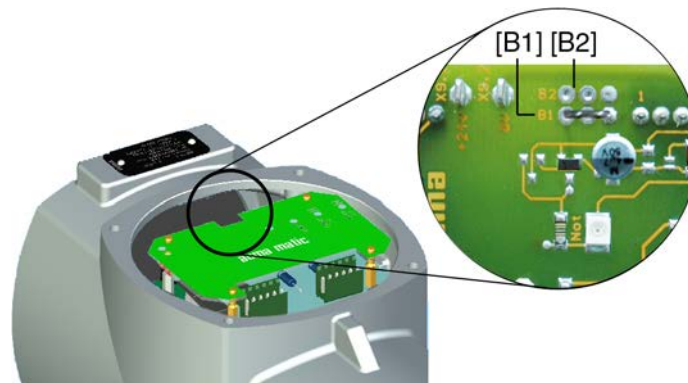

[B1] Link available: EMERGENCY - CLOSE

[B2] Link available: EMERGENCY - OPEN

1. Remove face plate.
2. Disconnect links [B1] or [B2].

11.9. Actuator controls: close

NOTICE

Danger of corrosion due to damage to paint finish!

- Touch up damage to paint finish after work on the device.

1. Clean sealing faces of housing and cover.
2. Check whether O-ring [3] is in good condition, replace if damaged.

3. Apply a thin film of non-acidic grease (e.g. petroleum jelly) to the O-ring and insert it correctly.

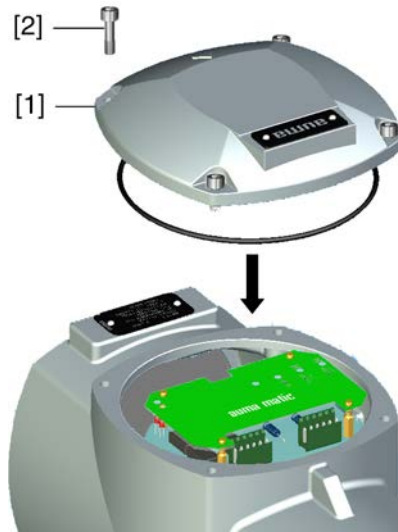

4. Place cover [1] on switch compartment.
5. Fasten screws [2] evenly crosswise.

12. Corrective action

12.1. Faults during operation/commissioning

Table 24:

Faults during operation/commissioning		
Fault	Description/cause	Remedy
Mechanical position indicator cannot be set.		Exchange reduction gearing.
In spite of correct setting of mechanical limit switching, actuator operates into the valve or actuator end position.	The overrun was not considered when setting the limit switching. The overrun is generated by the inertia of both the actuator and the valve and the delay time of the actuator controls.	<ul style="list-style-type: none"> Determine overrun: Overrun = travel covered from switching off until complete standstill. Set limit switching again considering the overrun. (Turn handwheel back by the amount of the overrun)
Measuring range 0/4 – 20 mA or maximum value 20 mA at position transmitter cannot be set or supplies an incorrect value.	Reduction gearing is not suitable for turns/stroke of the actuator.	Exchange reduction gearing.
The measuring range 0/4 – 20 mA at EWG position transmitter cannot be set.	The LED on the EWG either flashes in setting mode a) single flash or b) triple flash:  a) EWG is not calibrated. b) Magnet positions of EWG are not aligned.	Call service.
Limit and/or torque switches do not trip.	Switch is defective or switch setting is incorrect.	Check setting, if required, reset end positions. Refer to <Check switches> and replace the switches if required.

Switch check

The red test buttons [1] and [2] are used for manual operation of the switches:



- Turn test button [1] in direction of the TSC arrow: Torque switch CLOSED trips. The red indication light (fault) on the local controls is illuminated.
- Press push button OPEN to reset the fault (indication light) by operating the device in the opposite direction.
- Turn test button [2] in direction of the TSO arrow: Torque switch OPEN trips.
- Press push button CLOSE to reset the fault (indication light) by operating the device in the opposite direction.

If the actuator is equipped with a DUO limit switching (option), the intermediate position switches (LSA and LSB) will be operated at the same time as the torque switches.

- Turn test button [1] in direction of the LSC arrow: Limit switch CLOSED trips.
- Turn test button [2] in direction of the LSO arrow: Limit switch OPEN trips.

12.2. Fuses

12.2.1. Fuses within the actuator controls

After removal of local controls, the fuses can be accessed.



Hazardous voltage!

Risk of electric shock.

→ Disconnect device from the mains before opening.

F1/F2 Figure 52: Access to the primary fuses F1/F2

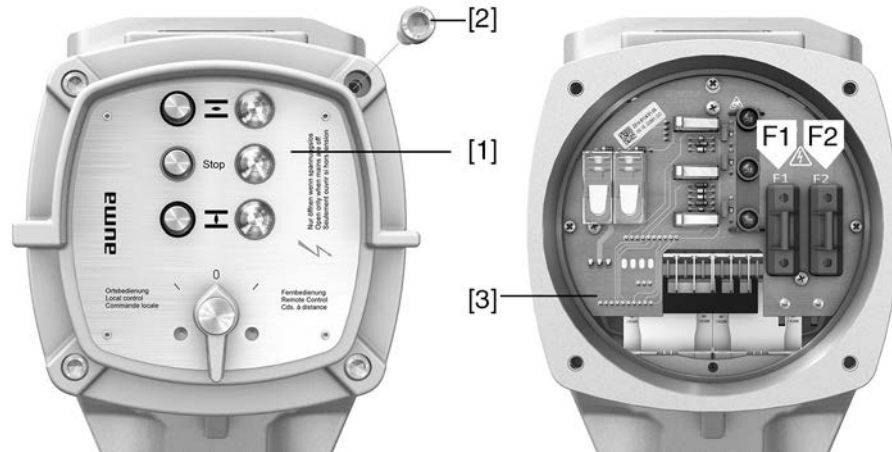

- [1] Local controls
- [2] Signal and control board
- [3] Power supply unit

Table 25:

Primary fuses F1/F2 (for power supply unit)		
G fuses	F1/F2	AUMA Art. no.:
Size	6.3 x 32 mm	
Power supply ≤ 500 V	1 A T; 500 V	K002.277
Power supply > 500 V	2 A FF; 690 V	K002.665

F3/F4 Figure 53: Access to secondary fuses F3/F4

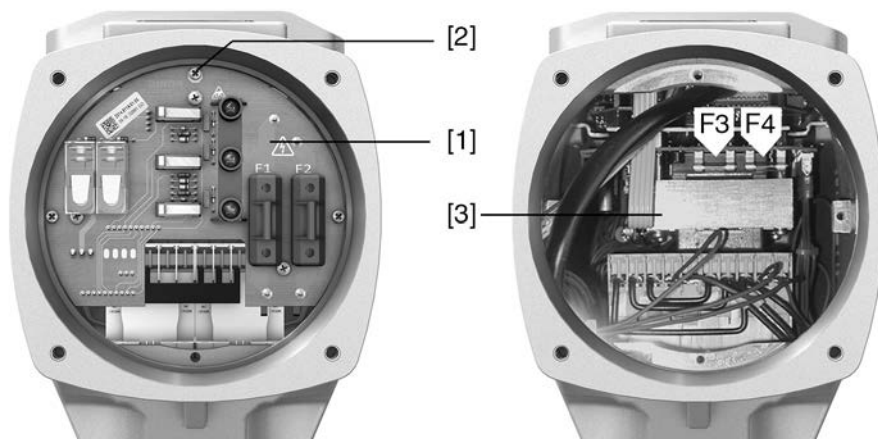

- [1] Signal and control board
- [2] Screws
- [3] Power supply unit (under Signal and control board)

Table 26:

Secondary fuse F3 (internal 24 V DC supply)		
G fuse according to IEC 60127-2/III	F3	AUMA Art.no.:
Size	5 x 20 mm	
Voltage output (power supply unit) = 24 V	500 mA T; 250 V	K001.183
Voltage output (power supply unit) = 115 V	500 mA T; 250 V	K001.183

Table 27:

Secondary fuse F4 (internal AC supply)¹⁾		
G fuse according to IEC 60127-2/III	F4	AUMA Art.no.:
Size	5 x 20 mm	
Voltage output (power supply unit) = 24 V	1.0 A T; 250 V	K004.831
	1.6 A T; 250 V	K003.131
Voltage output (power supply unit) = 115 V	0.4 A T; 250 V	K003.021

1) Fuse for: switch compartment heater, reversing contactor control, PTC tripping device (at 24 V AC only), at 115 V AC also control inputs OPEN, STOP, CLOSE

Information Only replace fuses with fuses of the same type and value.

→ After replacing the fuses, tighten local controls again.

NOTICE

Cable damage due to twisting or pinching!

Risk of functional failures.

- Turn local controls by a maximum of 180°.
- Carefully assemble local controls to avoid pinching the cables.

12.2.2. Motor protection (thermal monitoring)

In order to protect against overheating and impermissibly high surface temperatures at the actuator, PTC thermistors or thermostiches are embedded in the motor winding. The thermostat is tripped as soon as the max. permissible winding temperature has been reached.

The actuator is stopped and the "collective fault" indication light (option) on the local controls is illuminated.

The motor has to cool down before the operation can be resumed.

Version with thermostat (standard)

The actuator can be controlled again once the motor has cooled down ("collective fault" indication light goes out).

Version with thermostat and additional thermal overload relay in actuator controls (option)

The operation may only be resumed once the fault signal ("collective fault" indication light) has been reset. The fault signal is reset via the overload relay integrated in the actuator controls. Therefore, actuator controls have to be opened at the cover and the relay held down. The relay is located on the contactors.

Version with PTC thermistor (option)

The operation may only be resumed once the fault signal ("collective fault" indication light) has been reset. The fault signal is reset via selector switch position **Reset** of the local controls.

Figure 54: Selector switch on local controls

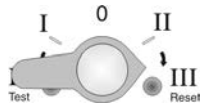

13. Servicing and maintenance



Damage caused by inappropriate maintenance!

- Servicing and maintenance must be carried out exclusively by suitably qualified personnel having been authorised by the end user or the contractor of the plant. Therefore, we recommend contacting our service.
- Only perform servicing and maintenance tasks when the device is switched off.

AUMA Service & Support

AUMA offers extensive service such as servicing and maintenance as well as customer product training. For the relevant contact addresses, please refer to <Addresses> in this document or to the Internet (www.auma.com)

13.1. Preventive measures for servicing and safe operation

The following actions are required to ensure safe device operation:

6 months after commissioning and then once a year

- Carry out visual inspection:
Check threaded plugs, cable entries, cable glands, blanking plugs, etc. for correct tightness and sealing.
Consider torques according to manufacturer's details.
- Check fastening screws between actuator and gearbox/valve for tightness. If required, fasten screws while applying the tightening torques as indicated in chapter <Assembly>.
- When rarely operated: Perform test run.
- For devices with output drive type A: Press in Lithium soap EP multi-purpose grease on mineral oil base at the grease nipple with a grease gun.
Figure 55: Output drive type A

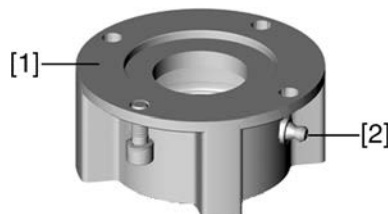

- [1] Output drive type A
- [2] Grease nipple

- Lubrication of the valve stem must be done separately.
Exception: For output drive type A in version with stem lubrication (option), the stem is lubricated together with the output drive.

Table 28:

Grease quantities for bearing of output drive type A				
Output drive type	A 07.2	A 10.2	A 14.2	A 16.2
Quantity [g] ¹⁾	1.5	3	5	10

1) For grease with density $\rho = 0.9 \text{ kg/dm}^3$

For enclosure protection IP68

After submersion:

- Check actuator.
- In case of ingress of water, locate leaks and repair. Dry device correctly and check for proper function.

13.2. Maintenance

- Lubrication**
- In the factory, the gear housing is filled with grease.
 - Grease change is performed during maintenance
 - Generally after 4 to 6 years for modulating duty.
 - Generally after 6 to 8 years if operated frequently (open-close duty).
 - Generally after 10 to 12 years if operated infrequently (open-close duty).
 - We recommend replacing the seals when changing the grease.
 - Additional lubrication of the gear housing is not required during operation.

13.3. Disposal and recycling

Our devices have a long lifetime. However, they have to be replaced at one point in time. The devices have a modular design and may, therefore, easily be separated and sorted according to materials used, i.e.:

- various metals
- plastics
- greases and oils

The following generally applies:

- Greases and oils are hazardous to water and must not be released into the environment.
- Arrange for controlled waste disposal of the disassembled material or for separate recycling according to materials.
- Observe the national regulations for waste disposal.

14. Technical data

Information The following tables include standard and optional features. For detailed information on the customer-specific version, refer to the order-related data sheet. The technical data sheet can be downloaded from the Internet in both German and English at <http://www.auma.com> (please state the order number).

14.1. Technical data Multi-turn actuators

Features and functions	
Type of duty (Multi-turn actuators for open-close duty)	Standard: Short-time duty S2 - 15 min, classes A and B according to EN 15714-2
	Option: with 3-phase AC motor: Short-time duty S2 - 30 min, classes A and B according to EN 15714-2
	For nominal voltage and 40 °C ambient temperature and at load with 35 % of the max. torque.
Type of duty (Multi-turn actuators for modulating duty)	Standard: Intermittent duty S4 - 25 %, class C according to EN 15714-2
	Option: with 3-phase AC motor: Intermittent duty S4 - 50 %, class C according to EN 15714-2 Intermittent duty S4 - 25 % (insulation class H required), class C according to EN 15714-2
	For nominal voltage and +40 °C ambient temperature and at modulating torque load.
Motors	Standard: 3-phase AC asynchronous motor, type IM B9 according to IEC 60034-7, IC410 cooling procedure according to IEC 60034-6
	Options: 1-phase AC motor with integral permanent split capacitor (PSC), type IM B9 according to IEC 60034-7, IC410 cooling procedure according to IEC 60034-6 1-phase AC motor with integral starting capacitor and solid state switch (CSIR), type IM B9 according to IEC 60034-7, IC410 cooling procedure according to IEC 60034-6 DC shunt motor, type IM B14 according to IEC 60034-7, IC410 cooling procedure according to IEC 60034-6 DC compound motor, type IM B14 according to IEC 60034-7, IC410 cooling procedure according to IEC 60034-6
	Mains voltage, mains frequency
	Refer to motor and actuator controls name plate Permissible variation of mains voltage: ±10 % Permissible variation of mains frequency: ±5 % (for 3-phase and 1-phase AC current)
Overvoltage category	Category III according to IEC 60364-4-443
Insulation class	Standard: F, tropicalized
	Option: H, tropicalized (with 3-phase AC motor)
Motor protection	Standard: Thermoswitches (NC), for 3-phase and 1-phase AC motors DC motors: Without
	Option: PTC thermistors (according to DIN 44082) PTC thermistors additionally require a suitable tripping device in the actuator controls.
Self-locking	Self-locking: Output speeds up to 90 rpm (50 Hz), 108 rpm (60 Hz) NOT self-locking: Output speeds from 125 rpm (50 Hz), 150 rpm (60 Hz) Multi-turn actuators are self-locking, if the valve position cannot be changed from standstill while torque acts upon the output drive.
Motor heater (option)	Voltages: 110 – 120 V AC, 220 – 240 V AC or 380 – 480 V AC for 3-phase AC motors Power depending on the size 12.5 – 25 W
Manual operation	Manual drive for setting and emergency operation, handwheel does not rotate during electrical operation.
	Option: Handwheel lockable Handwheel stem extension Power tool for emergency operation with square 30 mm or 50 mm
	Indication whether manual operation is active/not active via single switch (1 change-over contact)
Electrical connection	Standard: AUMA plug/socket connector with screw-type connection Motor connection for DC motors, via separate motor terminal board if required
	Option: Terminals or crimp connection Gold-plated control plug (sockets and pins)
Threads for cable entries	Standard: Metric threads
	Option: Pg-threads, NPT-threads, G-threads

Features and functions	
Terminal plan	Terminal plan according to order number enclosed with delivery
Valve attachment	Standard: B1 according to EN ISO 5210
	Option: A, B2, B3, B4, C, D according to EN ISO 5210 A, B, D, E according to DIN 3210 C according to DIN 3338
	Special valve attachments: AF, AK, AG, B3D, ED, DD, IB1, IB3 A prepared for permanent lubrication of stem
Electromechanical control unit	
Limit switching	Counter gear mechanism for end positions OPEN and CLOSED Turns per stroke: 2 to 500 (standard) or 2 to 5,000 (option)
	Standard: Single switch (1 NC and 1 NO) for each end position, not galvanically isolated
	Options: Tandem switch (2 NC and 2 NO) for each end position, switches galvanically isolated Triple switch (3 NC and 3 NO) for each end position, switches galvanically isolated Intermediate position switches (DUO limit switching), adjustable for each direction of operation
Torque switching	Torque switching adjustable for directions OPEN and CLOSE
	Standard: Single switch (1 NC and 1 NO) for each direction, not galvanically isolated
	Option: Tandem switch (2 NC and 2 NO) for each direction, switches galvanically isolated
Switch contact materials	Standard: Silver (Ag)
	Option: Gold (Au), recommended for low voltage actuator controls
Position feedback signal, analogue (options)	Potentiometer or 0/4 – 20 mA (electronic position transmitter)
Mechanical position indicator	Continuous indication, adjustable indicator disc with symbols OPEN and CLOSED
Running indication	Blinker transmitter (optional for modulating actuators)
Heater in switch compartment	Standard: Self-regulating PTC heater, 5 – 20 W, 110 – 250 V AC/DC
	Options: 24 – 48 V AC/DC (for actuators with 3-phase AC/1-phase AC/DC motors) or 380 – 400 V AC (for actuators with 3-phase AC motors)
	A resistance type heater of 5 W, 24 V AC is installed in the actuator in combination with AM or AC actuator controls.
Service conditions	
Use	Indoor and outdoor use permissible
Mounting position	Any position
Installation altitude	≤ 2 000 m above sea level
	> 2,000 m above sea level, on request
Ambient temperature	Refer to actuator name plate
Humidity	Up to 100 % relative humidity across the entire permissible temperature range
Enclosure protection according to EN 60529	Standard: IP68 (with AUMA 3-phase/1-phase AC or DC motor) For special motors differing enclosure protection available (refer to motor name plate)
	Option: DS Terminal compartment additionally sealed against interior (double sealed)
	According to AUMA definition, enclosure protection IP68 meets the following requirements: <ul style="list-style-type: none"> • Depth of water: Maximum 8 m head of water • Duration of continuous immersion in water: Maximum 96 hours • Up to 10 operations during flooding. • Modulating duty is not possible during continuous immersion.
	For exact version, refer to actuator name plate.
Pollution degree according to IEC 60664-1	Pollution degree 4 (when closed), pollution degree 2 (internal)
Vibration resistance according to IEC 60068-2-6	2 g, from 10 to 200 Hz (for actuators in AUMA NORM version) 1 g, from 10 to 200 Hz (for actuators with mounted AUMA actuator controls)
	Resistant to vibration during start-up or for failures of the plant. However, a fatigue strength may not be derived from this. Indications apply to actuators with AUMA 3-phase AC motor and AUMA plug/socket connector. They are not valid in combination with gearboxes.

Service conditions	
Corrosion protection	Standard: KS: Suitable for use in areas with high salinity, almost permanent condensation, and high pollution.
	Option: KX: Suitable for use in areas with extremely high salinity, permanent condensation, and high pollution.
	KX-G : same as KX, however aluminium-free version (outer parts)
Coating	Double layer powder coating Two-component iron-mica combination
Colour	Standard: AUMA silver-grey (similar to RAL 7037)
	Option: Other colours are possible on request.
Lifetime	AUMA multi-turn actuators meet or exceed the lifetime requirements of EN 15714-2. For further details, please contact AUMA
Noise level	< 72 dB (A)

Further information	
EU Directives	Electromagnetic Compatibility (EMC): (2014/30/EU) Low Voltage Directive: (2014/35/EU) Machinery Directive: (2006/42/EC)

Technical data for limit and torque switches	
Mechanical lifetime	2 x 10 ⁶ starts
Silver plated contacts:	
U min.	24 V AC/DC
U max.	250 V AC/DC
I min.	20 mA
I max. AC current	5 A at 250 V (resistive load)
	3 A at 250 V (inductive load, cos phi = 0.6)
I max. DC current	0.4 A at 250 V (resistive load)
	0.03 A at 250 V (inductive load, L/R = 3 µs)
	5 A at 30 V (resistive load)
	5 A at 30 V (inductive load, L/R = 3 µs)
Gold plated contacts	
U min.	5 V
U max.	50 V
I min.	4 mA
I max.	400 mA

Technical data for blinker transmitter	
Mechanical lifetime	10 ⁷ starts
Silver plated contacts:	
U min.	10 V AC/DC
U max.	250 V AC/DC
I max. AC current	3 A at 250 V (resistive load)
	2 A at 250 V (inductive load, cos phi ≈ 0.8)
I max. DC current	0.25 A at 250 V (resistive load)

Technical data for handwheel activation switches	
Mechanical lifetime	10 ⁶ starts
Silver plated contacts:	
U min.	12 V DC
U max.	250 V AC
I max. AC current	3 A at 250 V (inductive load, cos phi = 0.8)
I max. DC current	3 A at 12 V (resistive load)

14.2. Technical data Actuator controls

General information
Actuator controls AM 01.1/AM 02.1 for controlling multi-turn actuators of the SA/SAR .1, SA/SAR .2 type ranges and part-turn actuators of the SQ/SQR .2 type range.

Features and functions	
Power supply (mains voltage, mains frequency)	Refer to name plates at the controls and the motor Permissible variation of the mains voltage: $\pm 10\%$ Permissible variation of the mains frequency: $\pm 5\%$ Further permissible fluctuations of mains voltage and frequency (option): $(-20\%/+15\%)$, $(-20\%/+10\%)$, $(-30\%/+30\%)$, $(-30\%/+10\%)$
External supply of the electronics (option)	24 V DC $+20\%$ / -15% Current consumption: Basic version approx. 250 mA, with options up to 500 mA External power supply must have reinforced insulation against mains voltage in accordance with IEC 61010-1 and may only be supplied by a circuit limited to 150 VA in accordance with IEC 61010-1.
Current consumption	Current consumption of controls depending on mains voltage: For permissible variation of mains voltage of $\pm 10\%$: 100 to 120 V AC = max. 575 mA 208 to 240 V AC = max. 275 mA 380 to 690 V AC = max. 160 mA Current consumption for mains voltage variation: $> \pm 10\%$ on request
Overvoltage category	Category III according to IEC 60364-4-443
Rated power	
Switchgear	Standard: Reversing contactors (mechanically and electrically interlocked) for AUMA power classes A1/A2 Options: Reversing contactors (mechanically and electrically interlocked) for AUMA power classes A1/A2 with additional contacts, 1 NC + 1 NO each Reversing contactors (mechanically and electrically interlocked) for AUMA power class A3 Thyristor unit for mains voltage up to 500 V AC (recommended for modulating actuators) for AUMA power classes B1, B2 and B3 Reversing contactors are designed for a lifetime of 2 million starts. For applications requiring a high number of starts, we recommend using thyristor units. For the assignment of AUMA power classes, refer to the Electric data pertaining to the actuator.
Control inputs (control)	3 digital inputs: OPEN, STOP, CLOSE (via opto-isolator with one common), respect minimum pulse duration for modulating actuators
Control voltage/current consumption for control inputs	Standard: 24 V DC, current consumption: approx. 10 mA per input Option: 115 V AC, current consumption: approx. 15 mA per input

Features and functions		
Status signals (output signals)	Standard:	5 output contacts: <ul style="list-style-type: none"> • 4 NO contacts with one common, max. 250 V AC, 0.5 A (resistive load) <ul style="list-style-type: none"> - Default configuration: End position CLOSED, end position OPEN, selector switch REMOTE, selector switch LOCAL • 1 potential-free change-over contact, max. 250 V AC, 0.5 A (resistive load) for collective fault signal <ul style="list-style-type: none"> - Default configuration: Torque fault, phase failure, motor protection tripped
	Options:	5 output contacts with integrated running indication (blinking) for directions OPEN and CLOSE in combination with blinker transmitter <ul style="list-style-type: none"> • 4 NO contacts with one common, max. 250 V AC, 0.5 A (resistive load) <ul style="list-style-type: none"> - Default configuration: End position and running indication CLOSED, end position OPEN, selector switch REMOTE, selector switch LOCAL • 1 potential-free change-over contact, max. 250 V AC, 0.5 A (resistive load) for collective fault signal <ul style="list-style-type: none"> - Default configuration: Torque fault, phase failure, motor protection tripped
Voltage output	Standard:	Auxiliary voltage 24 V DC $\pm 5\%$, max. 50 mA for supply of control inputs, galvanically isolated from internal voltage supply
	Option:	115 V AC $\pm 10\%$, max. 30 mA for supply of the control inputs, galvanically isolated from internal voltage supply (Not possible in combination with PTC tripping device)
Local controls	Standard:	<ul style="list-style-type: none"> • Selector switch LOCAL - OFF - REMOTE (lockable in all three positions) • Push buttons OPEN, STOP, CLOSE • 3 indication lights: End position CLOSED (yellow), collective fault signal (red), end position OPEN (green)
	Options:	<ul style="list-style-type: none"> • Protection cover, lockable • Special colours for the 3 indication lights
Application functions	Standard:	<ul style="list-style-type: none"> • Selectable type of seating, limit or torque seating for end position OPEN and end position CLOSED • Overload protection against excessive torques over the whole travel • Excessive torque (torque fault) can be excluded from collective fault signal. • Phase failure monitoring with automatic phase correction • Push-to-run operation or self-retaining in REMOTE • Push-to-run operation or self-retaining in LOCAL • Blinker signal from actuator (option) for running indication via indication lights of local controls can be activated/deactivated.
	Options:	<ul style="list-style-type: none"> • Positioner for Split Range operation (requires position transmitter in actuator)
Motor protection evaluation	Standard:	<ul style="list-style-type: none"> • Monitoring the motor temperature in combination with thermostats within actuator motor
	Options:	<ul style="list-style-type: none"> • Additional thermal overload relay in the controls in combination with thermostats within the actuator • PTC tripping device in combination with PTC thermistors within actuator motor
Electrical connection	Standard:	AUMA plug/socket connector with screw-type connection
	Options:	<ul style="list-style-type: none"> • Terminals or crimp connection • Gold-plated control plug (sockets and plugs)
Threads for cable entries	Standard:	Metric threads
	Options:	Pg-threads, NPT-threads, G-threads
Wiring diagram	Refer to name plate	

Further options for version with electronic position transmitter in actuator

Position feedback signal (option)	Analogue output E2 = 0/4 – 20 mA (load max. 500 Ω)
-----------------------------------	--

Technical data

Service conditions	
Use	Indoor and outdoor use permissible
Mounting position	Any position
Installation altitude	≤ 2 000 m above sea level > 2,000 m above sea level, please contact AUMA
Ambient temperature	Refer to name plate of actuator controls
Enclosure protection according to EN 60529	Standard: IP68
	Option: DS Terminal compartment additionally sealed against interior (double sealed)
	According to AUMA definition, enclosure protection IP68 meets the following requirements: <ul style="list-style-type: none"> • Depth of water: maximum 8 m head of water • Duration of continuous immersion in water: Max. 96 hours • Up to 10 operations during continuous immersion • Modulating duty is not possible during continuous immersion. For exact version, refer to actuator controls name plate.
Pollution degree according to IEC 60664-1	Pollution degree 4 (when closed), pollution degree 2 (internal)
Vibration resistance according to IEC 60068-2-6	1 g, from 10 to 200 Hz Resistant to vibration during start-up or for failures of the plant. However, a fatigue strength may not be derived from this. (Not valid in combination with gearboxes)
Corrosion protection	Standard: KS: Suitable for use in areas with high salinity, almost permanent condensation, and high pollution.
	Options: KX: Suitable for use in areas with extremely high salinity, permanent condensation, and high pollution.
	KX-G: Same as KX, however aluminium-free version (outer parts)
Coating	Double layer powder coating Two-component iron-mica combination
Colour	Standard: AUMA silver-grey (similar to RAL 7037)
	Option: Available colours on request

Accessories	
Wall bracket	For AM mounted separately from the actuator, including plug/socket connector. Connecting cable on request. Recommended for high ambient temperatures, difficult access, or heavy vibration during service. Cable length between actuator and AM max. 100 m. Not suitable for version with potentiometer in the actuator. Instead of the potentiometer, the actuator has to be equipped with an electronic position transmitter.

Further information	
Weight	Approx. 7 kg (with AUMA plug/socket connector)
EU Directives	Electromagnetic Compatibility (EMC): (2014/30/EU) Low Voltage Directive: (2014/35/EU) Machinery Directive: (2006/42/EC)

15. Spare parts

15.1. Multi-turn actuators SA(V) 07.2 – SA(V) 16.2/SAR(V) 07.2 – SAR(V) 16.2

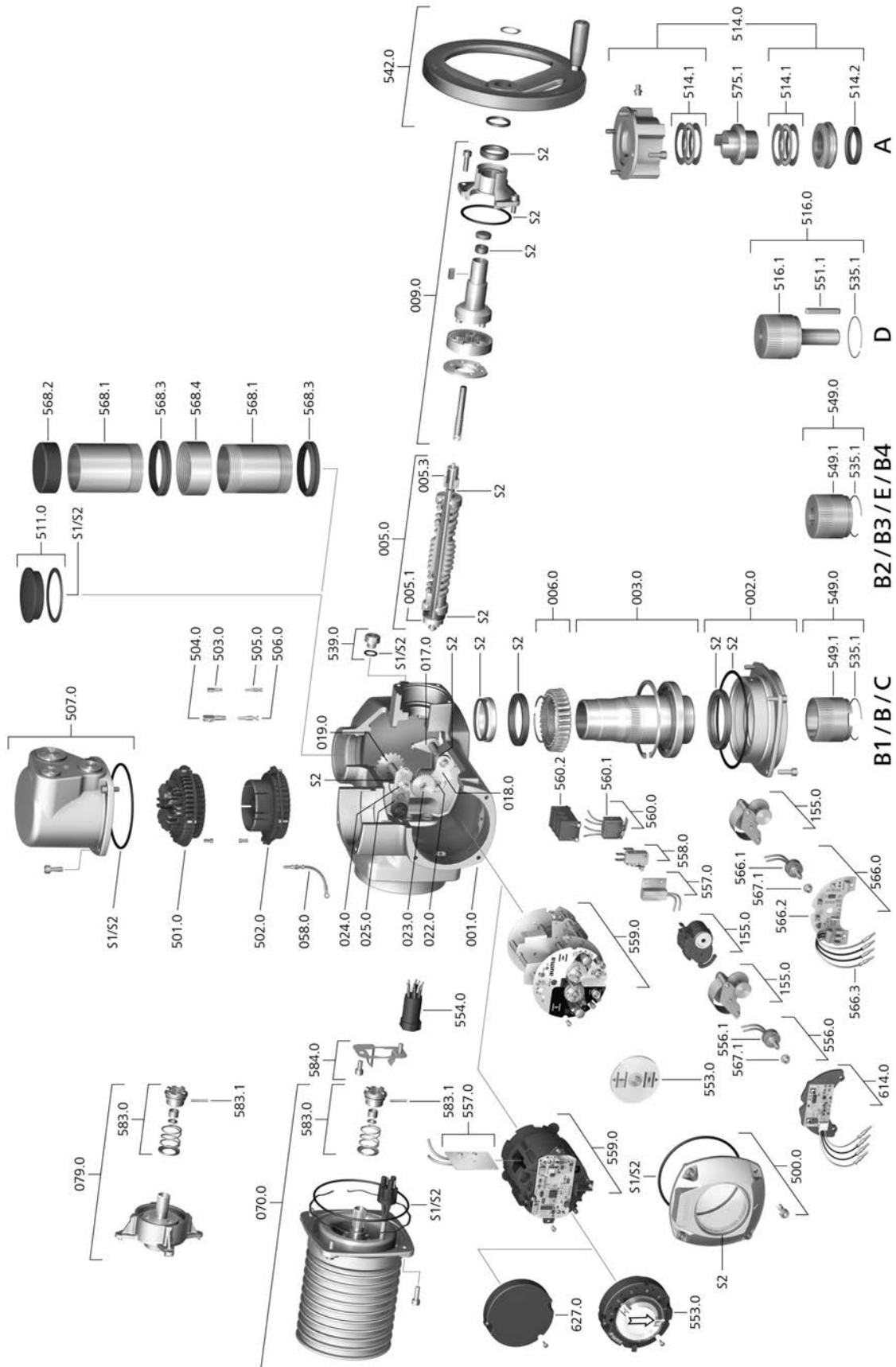

Spare parts

Please state device type and our order number (see name plate) when ordering spare parts. Only original AUMA spare parts should be used. Failure to use original spare parts voids the warranty and exempts AUMA from any liability. Representation of spare parts may slightly vary from actual delivery.

Ref. no.	Designation	Type	Ref. no.	Designation	Type
001.0	Housing	Sub-assembly	542.0	Handwheel with ball handle	Sub-assembly
002.0	Bearing flange	Sub-assembly	549.0	Output drive types B/B1/B2/B3/B4/C/E	Sub-assembly
003.0	Hollow shaft	Sub-assembly	549.1	Output drive sleeve B/B1/B2/B3/B4/C/E	Sub-assembly
005.0	Drive shaft	Sub-assembly	551.1	Parallel key	
005.1	Motor coupling		553.0	Mechanical position indicator	Sub-assembly
005.3	Manual drive coupling		554.0	Socket carrier for motor plug/socket connector with cable harness	Sub-assembly
006.0	Worm wheel		556.0	Potentiometer as position transmitter	Sub-assembly
009.0	Manual gearing	Sub-assembly	556.1	Potentiometer without slip clutch	Sub-assembly
017.0	Torque lever	Sub-assembly	557.0	Heater	
018.0	Gear segment		558.0	Blinker transmitter including pins at wires (without impulse disc and insulation plate)	Sub-assembly
019.0	Crown wheel		559.0–1	Electromechanical control unit with switches, including torque switching heads	Sub-assembly
022.0	Drive pinion II for torque switching	Sub-assembly	559.0–2	Electronic control unit with magnetic limit and torque transmitter (MWG)	Sub-assembly
023.0	Output drive wheel for limit switching	Sub-assembly	560.0–1	Switch stack for direction OPEN	Sub-assembly
024.0	Drive wheel for limit switching	Sub-assembly	560.0–2	Switch stack for direction CLOSE	Sub-assembly
025.0	Locking plate	Sub-assembly	560.1	Switch for limit/torque	Sub-assembly
058.0	Cable for protective earth	Sub-assembly	560.2–1	Switch case for direction OPEN	
070.0	Motor (only for V... motors incl. ref. no. 079.0)	Sub-assembly	560.2–2	Switch case for direction CLOSE	
079.0	Planetary gearing for motor drive (only for V... motors)	Sub-assembly	566.0	RWG position transmitter	Sub-assembly
155.0	Reduction gearing	Sub-assembly	566.1	Potentiometer for RWG without slip clutch	Sub-assembly
500.0	Cover	Sub-assembly	566.2	Position transmitter board for RWG	Sub-assembly
501.0	Socket carrier (complete with sockets)	Sub-assembly	566.3	Cable set for RWG	Sub-assembly
502.0	Pin carrier without pins	Sub-assembly	567.1	Slip clutch for potentiometer	Sub-assembly
503.0	Socket for controls	Sub-assembly	568.1	Stem protection tube (without cap)	
504.0	Socket for motor	Sub-assembly	568.2	Protective cap for stem protection tube	
505.0	Pin for controls	Sub-assembly	568.3	V-seal	
506.0	Pin for motor	Sub-assembly	568.4	Threaded sleeve	
507.0	Cover for electrical connection	Sub-assembly	575.1	Stem nut A (without thread)	
511.0	Threaded plug	Sub-assembly	583.0	Motor coupling on motor shaft	Sub-assembly
514.0	Output drive type A (without stem nut)	Sub-assembly	583.1	Pin for motor coupling	
514.1	Axial needle roller bearing	Sub-assembly	584.0	Retaining spring for motor coupling	Sub-assembly
514.2	Radial seal for output drive type A		614.0	EWG position transmitter	Sub-assembly
516.0	Output drive type D	Sub-assembly	627.0	MWG 05.03 cover	
516.1	Output drive shaft D		S1	Seal kit, small	Set
535.1	Snap ring		S2	Seal kit, large	Set
539.0	Screw plug	Sub-assembly			

15.2. Actuator controls AM 01.1/AM 02.1

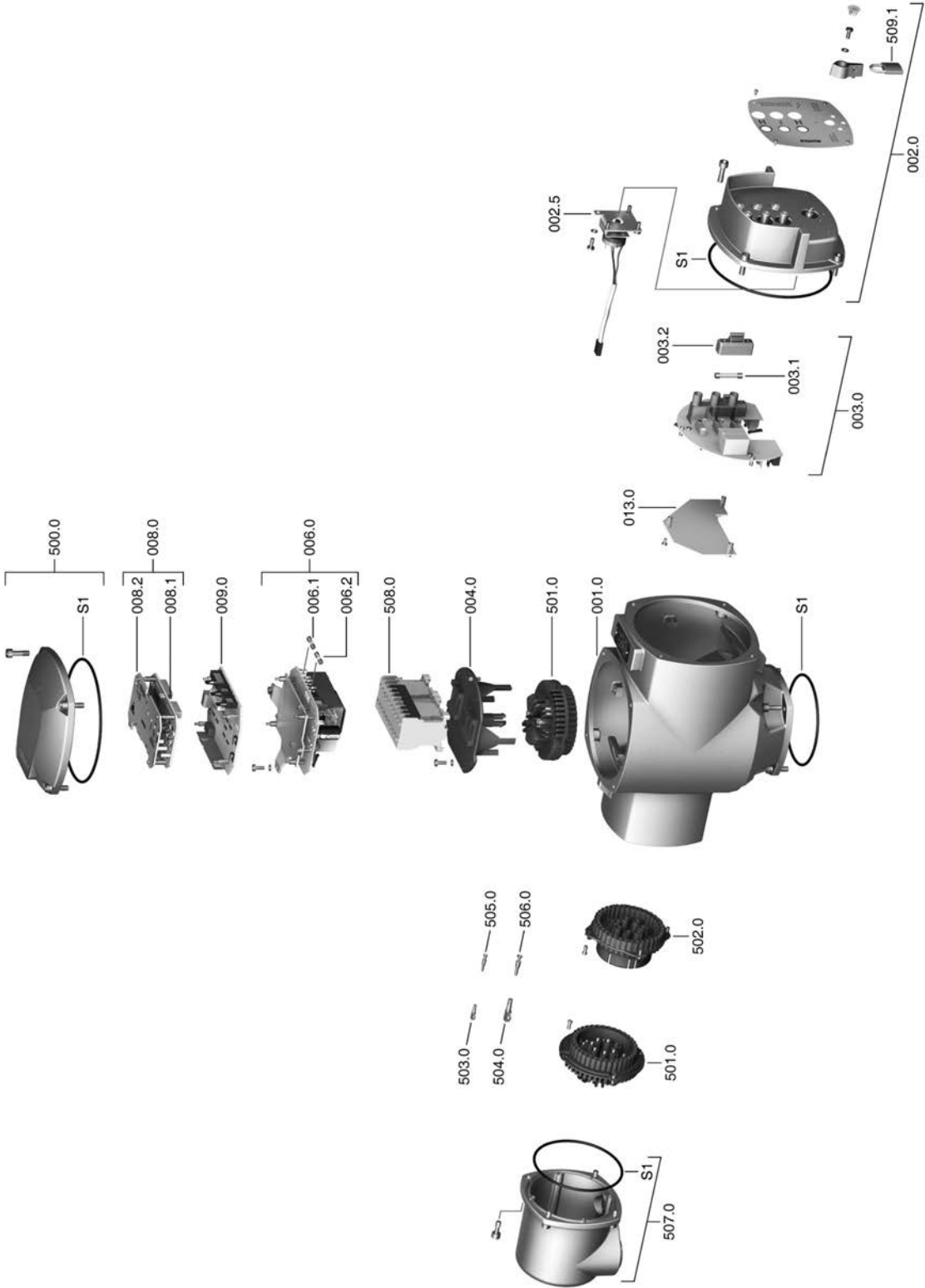

Spare parts

Please state device type and our order number (see name plate) when ordering spare parts. Only original AUMA spare parts should be used. Failure to use original spare parts voids the warranty and exempts AUMA from any liability. Representation of spare parts may slightly vary from actual delivery.

Ref. no.	Designation	Type
001.0	Housing	
002.0	Local controls	Sub-assembly
002.5	Selector switch	Sub-assembly
003.0	Signal and control board	Sub-assembly
003.1	Primary fuse F1/F2	
003.2	Fuse cover	
004.0	Carrier for contactors	
006.0	Power supply unit	Sub-assembly
006.1	Secondary fuse F3	
006.2	Secondary fuse F4	
008.0	Interface board	Sub-assembly
008.1	Interface board	
008.2	Cover plate for interface board	
009.0	Logic board	Sub-assembly
013.0	Adapter board	Sub-assembly
500.0	Cover	Sub-assembly
501.0	Socket carrier (complete with sockets)	Sub-assembly
502.0	Pin carrier without pins	Sub-assembly
503.0	Socket for controls	Sub-assembly
504.0	Socket for motor	Sub-assembly
505.0	Pin for controls	Sub-assembly
506.0	Pin for motor	Sub-assembly
507.0	Cover for electrical connection	Sub-assembly
508.0	Switchgear	Sub-assembly
509.1	Padlock	
S	Seal kit	Set

16. Certificates

Information Certificates are valid as from the indicated date of issue. Subject to changes without notice. The latest versions are attached to the device upon delivery and also available for download at <http://www.auma.com>.

16.1. Declaration of Incorporation and EU Declaration of Conformity

AUMA Riester GmbH & Co. KG
Aumastr. 1
79379 Müllheim, Germany
www.auma.com

Tel +49 7631 809-0
Fax +49 7631 809-1250
info@auma.com



EU Declaration of Conformity / Declaration of Incorporation in compliance with Machinery Directive

for electric actuators of the following type designations:

SA 07.2, SA 07.6, SA 10.2, SA 14.2, SA 14.6, SA 16.2,
SAR 07.2, SAR 07.6, SAR 10.2, SAR 14.2, SAR 14.6, SAR 16.2
SQ 05.2, SQ 07.2, SQ 10.2, SQ 12.2, SQ 14.2
SQR 05.2, SQR 07.2, SQR 10.2, SQR 12.2, SQR 14.2

in versions:

AUMA NORM
AUMA SEMIPACT SEM 01.1, SEM 02.1
AUMA MATIC AM 01.1, AM 02.1
AUMATIC AC 01.2

AUMA Riester GmbH & Co. KG as manufacturer declare herewith, that the above mentioned actuators meet the basic requirements of the following Directives:

2014/30/EU (EMC Directive)
2006/42/EC (Machinery Directive)

The following harmonised standards in terms of the specified directives have been applied:

Directive 2014/30/EU

EN 61000-6-4:2007 / A1:2011
EN 61000-6-2:2005 / AC:2005

Directive 2006/42/EC

EN ISO 12100:2010
EN ISO 5210:1996

AUMA actuators are designed for the operation of industrial valves. Putting into service is prohibited until the final machinery has been declared in conformity with the provisions of Directive 2006/42/EC.

The following basic requirements in compliance with Annex I of the Directive are respected:

Appendix I, articles 1.1.2, 1.1.3, 1.1.5, 1.2.1, 1.2.6, 1.3.1, 1.3.7, 1.5.1, 1.6.3, 1.7.1, 1.7.3, 1.7.4

The manufacturer shall be obligated to electronically submit the documents for the partly completed machinery to national authorities on request. The relevant technical documentation pertaining to the machinery described in Annex VII, part B has been prepared.

Authorised person for documentation: Peter Malus, Aumastrasse 1, 79379 Müllheim, Germany

Furthermore, the essential health and safety requirements in compliance with Directive 2014/35/EU (Low Voltage Directive) are fulfilled by applying the following harmonised standards, as far as applicable for the products:

EN 60204-1:2006 / A1:2009 / AC:2010
EN 60034-1:2010 / AC:2010
EN 50178:1997

Müllheim, 2016-04-01

H. Newerla, Managing Director

This declaration does not contain any guarantees. The safety instructions in product documentation supplied with the devices must be observed. Non-concerted modification of the devices voids this declaration.

Y006.332/003/en/1.16

Index**A**

Accessories (electrical connection)	30
Accessories for assembly	21
Actual value	54
Actuator operation from remote	35
Ambient temperature	8, 9, 68, 72
Analogue signals	38
Applications	5
Assembly	16
Assistant App	11
AUMA Assistant App	11

B

Behaviour on loss of signal	55
Blinker transmitter: activate/deactivate	53

C

Cable entries	67
Cables	25
Cable set	30
Certificates	77
Coating	72
Collective fault signal	36, 38
Colour	72
Commissioning	5
Commissioning – controls	51
Connecting cable	30
Connecting cables	25
Control	9, 10
Control inputs Potential	25
Control voltage	10
Corrective action	61
Corrosion protection	14, 69, 72
Current consumption	24
Current type	24

D

Data Matrix code	11
Dead band	58
Dead time	58
Declaration of Incorporation	77
Device type	10
Direction of rotation	43, 43
Directives	5
Disposal	66
Double sealed	31
DUO limit switching	42

E

Earth connection	32
Electrical connection	24, 67
Electronic position transmitter	46, 49
EMC	25
EMERGENCY command	59
Enclosure protection	8, 9, 9, 68, 72
End position signalling	48
EU Declaration of Conformity	77
EWG	46
EWG position transmitter	46

F

Fault	61
Flange size	10
Frequency range	24
Fuses	61

H

Handwheel	16
Heat-up time	39
Hollow shaft	43
Humidity	68

I

Identification	8
Indication lights	36
Indications	36
Indicator disc	50
Indicator mark	36
Input current	10
Input ranges	54
Input signal	10
Input signals Potential	25
Inspection certificate	10
Installation altitude	72
Insulation class	9, 67
Intermediate frame	31
Intermediate positions	42
Inverse operation (0/20 – 4 mA)	47

L

LED end position signalling	48
Lifetime	69
Limit seating	51
Limit switching	40, 44
Local control	34
Local controls	34
Loss of signal	55
Low temperature version	39
Lubrication	66

M		R	
Mains frequency	9, 9, 67	Range of application	5
Mains voltage	9, 9, 24, 67	Rated current	9
Maintenance	5, 65, 66	Rated power	9
Manual operation	33, 67	Recycling	66
Mechanical position indicator	36, 50	Remote actuator operation	35
Motor heater	67	Residual current device (RCD)	25
Motor operation	34	Running indication	36, 36
Motor protection	9, 67	Running indication: activate/deactivate	53
Motor protection LED	53	RWG	49
Motors	67	S	
Motor type	9	Safety instructions	5
Mounting position	72	Safety instructions/warnings	5
N		Safety measures	25
Name plate	8	Safety standards	25
O		Self-locking	67
Operation	5, 33	Self-retaining: set	52
Order number	8, 9, 10	Serial number	8, 9, 10
Output drive type A	16	Service	65
Output drive types B	19	Servicing	65
Output signals	38	Setpoint	54
Output signals Potential	25	Short-circuit protection	24
Overvoltage category	67	Signals	38
P		Signals (analogue)	38
Packaging	15	Signal type	54
Parking frame	31	Size	10
Phase failure LED	53	Spare parts	73
Pollution degree	72	Speed	8, 9
Positioner	54	Standards	5
Positioner adjustment	56	Status signals Potential	25
Positioner sensitivity	58	Stem	43
Position indicator	36, 50	Stem nut	17
Position transmitter (EWG)	46	Stem protection tube	21
Position transmitter (RWG)	49	Storage	14
Potentiometer	48	Supply networks	24
Power class	9	Support	65
Power class for switchgear	10	Switch check	61
Power factor	9		
Power supply of electronics	24		
Production, year	10		
Protection on site	24		
Protective measures	5		
PTC tripping device	45		
Push-to-run operation: set	52		
Q			
Qualification of staff	5		

T

Technical data	67
Technical data for switches	69
Temperature protection	9
Terminal plan	24, 68
Terminal plan for actuator	9
Test run	43
Torque fault LED	53
Torque fault signal: activate/deactivate	53
Torque range	8
Torque seating	51
Torque switching	40
Transport	12
Type (device type)	10
Type designation	8, 9
Type of current	9
Type of duty	9, 67
Type of lubricant	8
Type of networks	24
Type of seating: set	51

V

Valve attachment	68
Valve stem	21
Vibration resistance	72
Voltage range	24

W

Wall bracket	30
Wiring diagram	10, 24
Wiring diagram for controls	9

Y

Year of production	10
--------------------	----

Europe

AUMA Riester GmbH & Co. KG

Location Muellheim
DE 79373 Muellheim
 Tel +49 7631 809 - 0
 info@auma.com
 www.auma.com

Location Ostfildern-Nellingen
DE 73747 Ostfildern
 Tel +49 711 34803 - 0
 riester@auma.com

Service-Center Bayern
DE 85386 Eching
 Tel +49 81 65 9017- 0
 Service.SCB@auma.com

Service-Center Köln
DE 50858 Köln
 Tel +49 2234 2037 - 900
 Service@sck.auma.com

Service Center Magdeburg
DE 39167 Niederndodeleben
 Tel +49 39204 759 - 0
 Service@scm.auma.com

AUMA-Armaturentriebe Ges.m.b.H.
AT 2512 Tribuswinkel
 Tel +43 2252 82540
 office@auma.at
 www.auma.at

AUMA BENELUX B.V. B. A.
BE 8800 Roeselare
 Tel +32 51 24 24 80
 office@auma.be
 www.auma.nl

ProStream Group Ltd.
BG 1632 Sofia
 Tel +359 2 9179-337
 valtchev@prostream.bg
 www.prostream.bg

OOO "Dunkan-Privod"
BY 220004 Minsk
 Tel +375 29 6945574
 belarus@auma.ru
 www.zatvor.by

AUMA (Schweiz) AG
CH 8965 Berikon
 Tel +41 566 400945
 RettichP.ch@auma.com

AUMA Servopohony spol. s.r.o.
CZ 250 01 Brandýs n.L.-St.Boleslav
 Tel +420 326 396 993
 auma-s@auma.cz
 www.auma.cz

IBEROPLAN S.A.
ES 28027 Madrid
 Tel +34 91 3717130
 iberoplan@iberoplan.com

AUMA Finland Oy
FI 02230 Espoo
 Tel +358 9 5840 22
 auma@auma.fi
 www.auma.fi

AUMA France S.A.R.L.
FR 95157 Taverny Cedex
 Tel +33 1 39327272
 info@auma.fr
 www.auma.fr

AUMA ACTUATORS Ltd.
GB Clevedon, North Somerset BS21 6TH
 Tel +44 1275 871141
 mail@auma.co.uk
 www.auma.co.uk

D. G. Bellos & Co. O.E.
GR 13673 Acharnai, Athens
 Tel +30 210 2409485
 info@dgbellos.gr

APIS CENTAR d. o. o.
HR 10437 Bestovje
 Tel +385 1 6531 485
 auma@apis-centar.com
 www.apis-centar.com

Fabo Kereskedelmi és Szolgáltató Kft.
HU 8800 Nagykanizsa
 Tel +36 93/324-666
 auma@fabo.hu
 www.fabo.hu

Falkinn HF
IS 108 Reykjavik
 Tel +00354 540 7000
 os@falkinn.is
 www.falkinn.is

AUMA ITALIANA S.r.l. a socio unico
IT 20023 Cerro Maggiore (MI)
 Tel +39 0331 51351
 info@auma.it
 www.auma.it

AUMA BENELUX B.V.
LU Leiden (NL)
 Tel +31 71 581 40 40
 office@auma.nl

NB Engineering Services
MT ZBR 08 Zabbar
 Tel + 356 2169 2647
 nikibel@onvol.net

AUMA BENELUX B.V.
NL 2314 XT Leiden
 Tel +31 71 581 40 40
 office@auma.nl
 www.auma.nl

SIGUM A. S.
NO 1338 Sandvika
 Tel +47 67572600
 post@sifag.no

AUMA Polska Sp. z o.o.
PL 41-219 Sosnowiec
 Tel +48 32 783 52 00
 biuro@auma.com.pl
 www.auma.com.pl

AUMA-LUSA Representative Office, Lda.
PT 2730-033 Barcarena
 Tel +351 211 307 100
 geral@aumalusa.pt

SAUTECH
RO 011783 Bucuresti
 Tel +40 372 303982
 office@sautech.ro

OOO PRIWODY AUMA
RU 141402 Khimki, Moscow region
 Tel +7 495 221 64 28
 amarusia@auma.ru
 www.auma.ru

OOO PRIWODY AUMA
RU 125362 Moscow
 Tel +7 495 787 78 21
 amarusia@auma.ru
 www.auma.ru

AUMA Scandinavia AB
SE 20039 Malmö
 Tel +46 40 311550
 info.scandinavia@auma.com
 www.auma.se

ELSO-b, s.r.o.
SK 94901 Nitra
 Tel +421 905/336-926
 office@elsob.sk
 www.elsob.sk

Auma Endüstri Kontrol Sistemleri Limited
 Sirketi
TR 06810 Ankara
 Tel +90 312 217 32 88
 info@auma.com.tr

AUMA Technology Automations Ltd
UA 02099 Kiev
 Tel +38 044 586-53-03
 auma-tech@aumatech.com.ua

Africa

Solution Technique Contrôle Commande
DZ Bir Mourad Rais, Algiers
 Tel +213 21 56 42 09/18
 stcco@wissal.dz

A.T.E.C.
EG Cairo
 Tel +20 2 23599680 - 23590861
 contactus@atec-eg.com

SAMIREG
MA 203000 Casablanca
 Tel +212 5 22 40 09 65
 samireg@menara.ma

MANZ INCORPORATED LTD.
NG Port Harcourt
 Tel +234-84-462741
 mail@manzincorporated.com
 www.manzincorporated.com

AUMA South Africa (Pty) Ltd.
ZA 1560 Springs
 Tel +27 11 3632880
 aumasa@mweb.co.za

America

AUMA Argentina Rep.Office
AR Buenos Aires
 Tel +54 11 4737 9026
 contacto@aumaargentina.com.ar

AUMA Automação do Brazil Ltda.
BR Sao Paulo
 Tel +55 11 4612-3477
 contato@auma-br.com

TROY-ONTOR Inc.
CA L4N 8X1 Barrie, Ontario
 Tel +1 705 721-8246
 troy-ontor@troy-ontor.ca

AUMA Chile Representative Office
CL 7870163 Santiago
 Tel +56 2 2821 4108
 claudio.bizama@auma.com

B & C Biosciences Ltda.
CO Bogotá D.C.
 Tel +57 1 349 0475
 proyectos@bycenlinea.com
 www.bycenlinea.com

AUMA Región Andina & Centroamérica
EC Quito
 Tel +593 2 245 4614
 auma@auma-ac.com
 www.auma.com

Corsusa International S.A.C.
PE Miraflores - Lima
 Tel +511444-1200 / 0044 / 2321
 corsusa@corsusa.com
 www.corsusa.com

Control Technologies Limited
TT Marabella, Trinidad, W.I.
 Tel + 1 868 658 1744/5011
 www.ctltech.com

AUMA ACTUATORS INC.
US PA 15317 Canonsburg
 Tel +1 724-743-2862
 mailbox@auma-usa.com
 www.auma-usa.com

Suplibarca
VE Maracaibo, Estado, Zulia
 Tel +58 261 7 555 667
 suplibarca@intercable.net.ve

Asia

AUMA Actuators UAE Support Office
AE 287 Abu Dhabi
 Tel +971 26338688
 Nagaraj.Shetty@auma.com

AUMA Actuators Middle East
BH 152 68 Salmabad
 Tel +97 3 17896585
 salesme@auma.com

Mikuni (B) Sdn. Bhd.
BN KA1189 Kuala Belait
 Tel + 673 3331269 / 3331272
 mikuni@brunet.bn

AUMA Actuators (China) Co., Ltd.
CN 215499 Taicang
 Tel +86 512 3302 6900
 mailbox@auma-china.com
 www.auma-china.com

PERFECT CONTROLS Ltd.
HK Tsuen Wan, Kowloon
 Tel +852 2493 7726
 joeip@perfectcontrols.com.hk

PT. Carakamas Inti Alam
ID 11460 Jakarta
 Tel +62 215607952-55
 auma-jkt@indo.net.id

AUMA INDIA PRIVATE LIMITED.
IN 560 058 Bangalore
 Tel +91 80 2839 4656
 info@auma.co.in
 www.auma.co.in

ITG - Iranians Torque Generator
IR 13998-34411 Teheran
 +982144545654
 info@itg-co.ir

Trans-Jordan Electro Mechanical Supplies
JO 11133 Amman
 Tel +962 - 6 - 5332020
 Info@transjordan.net

AUMA JAPAN Co., Ltd.
JP 211-0016 Kawasaki-shi, Kanagawa
 Tel +81-(0)44-863-8371
 mailbox@auma.co.jp
 www.auma.co.jp

DW Controls Co., Ltd.
KR 153-702 Gasan-dong, GeumChun-Gu,, Seoul
 Tel +82 2 2624 3400
 import@actuatorbank.com
 www.actuatorbank.com

Al-Arfaj Engineering Co WLL
KW 22004 Salmiyah
 Tel +965-24817448
 info@arfajengg.com
 www.arfajengg.com

TOO "Armaturny Center"
KZ 060005 Atyrau
 Tel +7 7122 454 602
 armacentre@bk.ru

Network Engineering
LB 4501 7401 JBEIL, Beirut
 Tel +961 9 944080
 nabil.ibrahim@networkenglb.com
 www.networkenglb.com

AUMA Malaysia Office
MY 70300 Seremban, Negeri Sembilan
 Tel +606 633 1988
 sales@auma.com.my

Mustafa Sultan Science & Industry Co LLC
OM Ruwi
 Tel +968 24 636036
 r-negi@mustafasultan.com

FLOWTORK TECHNOLOGIES
 CORPORATION
PH 1550 Mandaluyong City
 Tel +63 2 532 4058
 flowtork@pltdsl.net

M & C Group of Companies
PK 54000 Cavalry Ground, Lahore Cantt
 Tel +92 42 3665 0542, +92 42 3668 0118
 sales@mcss.com.pk
 www.mcss.com.pk

Petrogulf W.L.L.
QA Doha
 Tel +974 44350151
 pgulf@qatar.net.qa

AUMA Saudi Arabia Support Office
SA 31952 Al Khobar
 Tel + 966 5 5359 6025
 Vinod.Fernandes@auma.com

AUMA ACTUATORS (Singapore) Pte Ltd.
SG 569551 Singapore
 Tel +65 6 4818750
 sales@auma.com.sg
 www.auma.com.sg

NETWORK ENGINEERING
SY Homs
 +963 31 231 571
 eyad3@scs-net.org

Sunny Valves and Intertrade Corp. Ltd.
TH 10120 Yannawa, Bangkok
 Tel +66 2 2400656
 mainbox@sunnyvalves.co.th
 www.sunnyvalves.co.th

Top Advance Enterprises Ltd.
TW Jhonghe City, Taipei Hsien (235)
 Tel +886 2 2225 1718
 support@auma-taiwan.com.tw
 www.auma-taiwan.com.tw

AUMA Vietnam Hanoi RO
VN Hanoi
 +84 4 37822115
 chiennguyen@auma.com.vn

Australia

BARRON GJM Pty. Ltd.
AU NSW 1570 Artarmon
 Tel +61 2 8437 4300
 info@barron.com.au
 www.barron.com.au

auma[®]

Solutions for a world in motion

AUMA Riester GmbH & Co. KG

P.O. Box 1362

DE 79373 Muellheim

Tel +49 7631 809 - 0

Fax +49 7631 809 - 1250

info@auma.com

www.auma.com