

Single window sight glasses

Double window sight glasses

Model 265

Threaded connection
Flange connection

Model 365
Model 366



To verify the flow, direction and condition of liquid in a section of piping.

It helps detect blockages in valves, filters and other line equipment.

In particular, it enables verification of correct operation of the condensate traps, ensuring that there are no steam leaks, with the cost this would entail.

It also enables observation of a product's viscosity, turbidity and, in particular, its colour in the different phases of its production process.

Applicable to: piping conveying liquids, steam and condensates, among others, in any type of industry: chemical, petrochemical, pharmaceutical, food and more.

In accordance with the requirements of Directive 2014/68/EU.

EC verification of certified sight glasses by TÜV Rheinland Industrie Service GmbH, Notified Body for Pressure Equipment ID-No. 0035.

Final EC product verification test (Module B) certified by: TÜV Rheinland Ibérica ICT, S.A.

In accordance with ATEX Directive 2014/34/EU "Equipment and protective systems intended for use in potentially explosive atmospheres".

Specifications

- Reduced assembly length as per EN-558-1 type series 1.
- Materials carefully selected for resistance to wear, temperature and corrosion. Fully recyclable.
- Circular sight glasses in borosilicate as per DIN-7080, high chemical stability, extraordinary purity and homogeneity. Low thermal expansion coefficient. Prestressed by heat to guarantee a high mechanical strength. High resistance to sudden temperature or pressure changes and chemical attack, guaranteeing a long service life. Perfectly ground seal surfaces. Glass does not shatter if accidentally broken.
- Simple construction.
- No moving parts, guaranteeing minimum maintenance.
- Compact, robust. Reduced weight and size, facilitating storage.
- Designed to allow a clear, accurate view of the fluid.
- Simple to install, can be mounted in any position.
- The markings on the body specify the service and assembly conditions.
- Silent.
- All sight glasses undergo strict tests and checks.
- Each component is numbered, registered and monitored. If requested beforehand, the sight glass will be delivered with certifications of materials, casts, tests and yields.

IMPORTANT

We recommend, if necessary, the use of thermal and acoustic insulation textile jackets Model 008.

On order:

- Option for manufacturing in other materials for special working conditions (high temperatures, fluids, etc).
 - Other connections.
 - Mica plates. When combined with transparent glass, they prolong the latter's life at high pressures and temperatures. They also protect from erosion caused by aggressive chemicals, alkaline solutions, boiler water, steam, caustic products hydrofluoric acids, hot, concentrated phosphoric acids, sodium and potassium hydroxides and other contaminated, viscous or corrosive media.
- Applicable in sight glasses for electricity generating plants, thermal power stations, oil refineries, petrochemical plants, pressure vessels, fertilizers, sugar mills, paper mills and more.

EN ASME/FNPT ASME/SW ASME/ANSI

N°. PIECE	PIECE	MODEL 265-365							
		MATERIAL							
		CARBON STEEL				STAINLESS STEEL			
1	Body	Carbon steel (EN-1.0580)(1)				Stainless steel (EN-1.4401)			
2	Cover	Carbon steel (EN-1.0580)(1)				Stainless steel (EN-1.4401)			
3	Seal	Graphite							
4	Glass	Borosilicate							
5	Screw	Carbon steel (EN-1.1191)				Stainless steel (EN-1.4401)			
6	Washer	Carbon steel (EN-1.1141)				Stainless steel (EN-1.4401)			
R		1/2" to 2" (GAS,NPT, SW)							
PN		40				40			
OPERATING CONDITIONS	PRESSURE IN bar	40	35	28	24	40	34	32	29
	MAX.TEMPERATURE IN °C	120	200	280	280	120	200	280	280
	MIN. TEMPERATURE IN °C	-10				-60			

(1) R.1/2" to 1 in Carbon steel (EN-1.1191)

N°. PIECE	PIECE	MODEL 366															
		MATERIAL															
		CARBON STEEL								STAINLESS STEEL							
1	Body	Carbon steel (EN-1.0580)(1)								Stainless steel (EN-1.4401)							
2	Cover	Carbon steel (EN-1.0580)(1)								Stainless steel (EN-1.4401)							
3	Seal	Graphite															
4	Glass	Borosilicate															
5	Screw	Carbon steel (EN-1.1191)								Stainless steel (EN-1.4401)							
6	Washer	Carbon steel (EN-1.1141)								Stainless steel (EN-1.4401)							
7	Threaded pin	Carbon steel (EN-1.1181)								Stainless steel (EN-1.4401)							
8	Nut	Carbon steel (EN-1.1141)								Stainless steel (EN-1.4401)							
9	Inlet flange	Carbon steel (EN-1.0460)								Stainless steel (EN-1.4401)							
10	Outlet flange	Carbon steel (EN-1.0308)								Stainless steel (EN-1.4401)							
DN		15 to 200 (EN, ANSI)															
PN		16				40				16				40			
OPERATING CONDITIONS	PRESSURE IN bar	16	13	13	13	40	35	28	24	16	13	13	13	40	34	32	29
	MAX.TEMPERATURE IN °C	120	200	250	280	120	200	250	280	120	200	250	280	120	200	250	280
	MIN. TEMPERATURE IN °C	-10								-60							

(1) DN-15 to 25 in Carbon steel (EN-1.1191)

ADDITIONAL RESTRICTIONS:

- PN-16 DN-200 PMS-8,5 bar
- PN-40 DN-100 PMS-25 bar
- PN-40 DN-125 PMS-25 bar
- PN-40 DN-150 PMS-16 bar

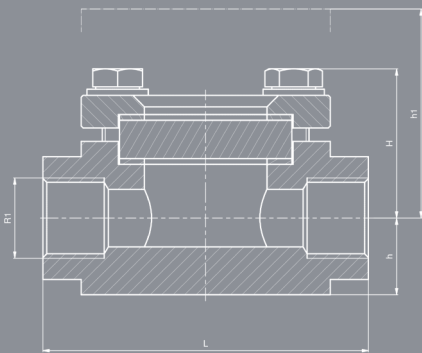

Mod. 265

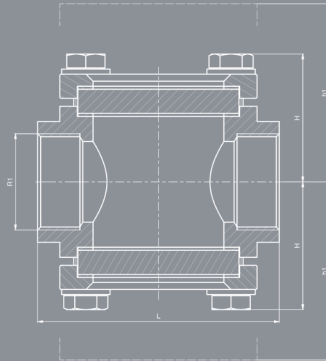

Mod. 365

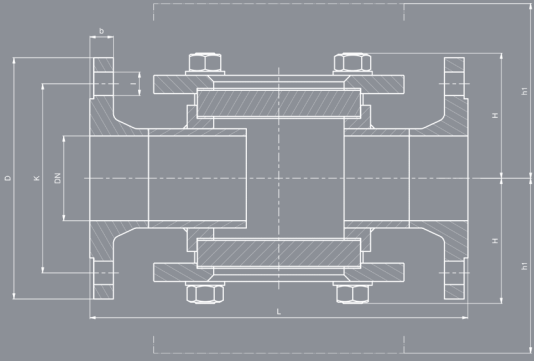

Mod. 366

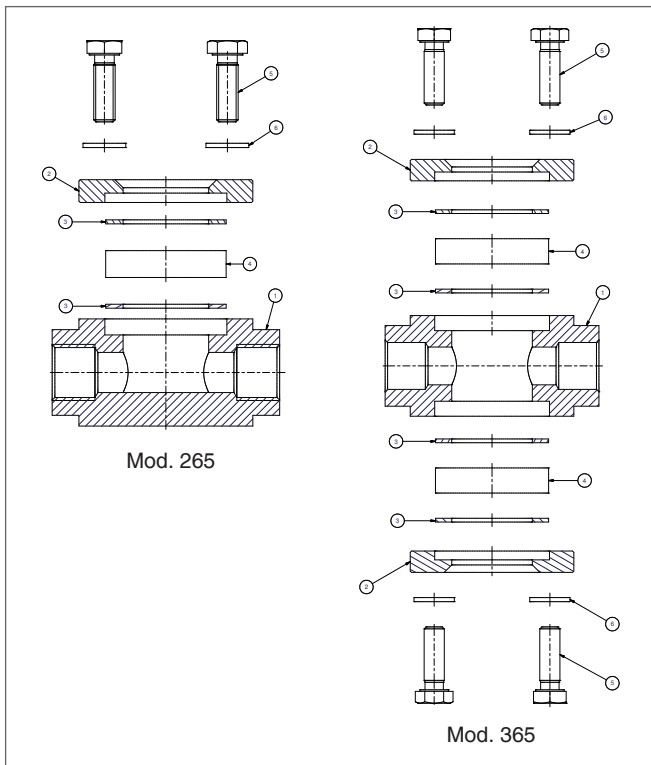

Mod. 366
DN15, DN20, DN25

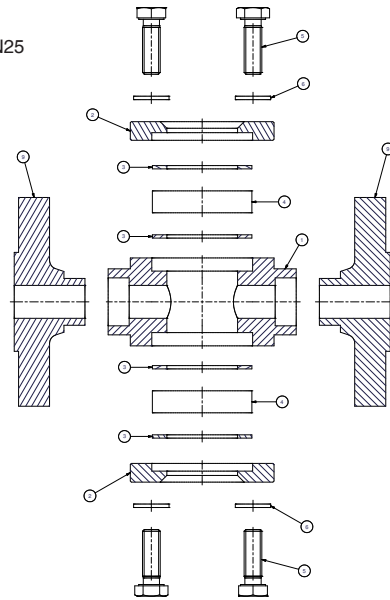

DN32, DN40, DN50

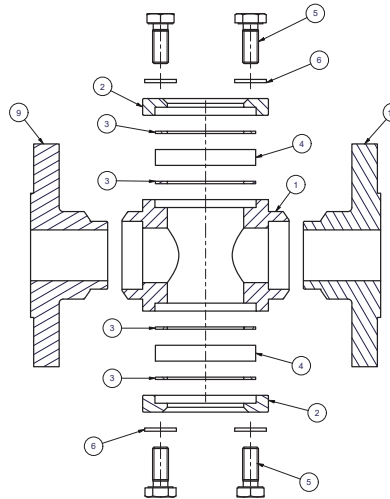

DN65, DN80, DN100, DN125, DN150 and DN200

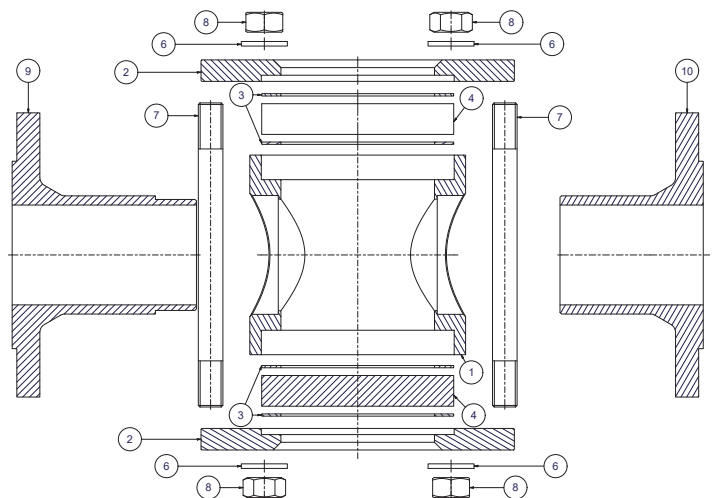

Installation

It can be installed downstream from valves, filters and other line equipment.

If it is installed after a condensate trap, install at the lowest point. If the trap discharges intermittently, we recommend installing it 1 metre downstream to avoid erosive wear. Provide cut-off valves to close sections off for maintenance.

Use safety glasses to observe liquid flow through a sight glass.

Maintenance

In certain applications, erosion is caused by aggressive chemicals, alkaline solutions, boiler water, steam, caustic products, hydrofluoric acids, hot, concentrated phosphoric acids, sodium and potassium hydroxides and other contaminated, viscous or corrosive media. If any signs of wear are observed, change the glass immediately.

Before dismantling the sight glass, remember to depressurize and close off the area with the cut-off valves.

Check which fluid was being conveyed and whether additional precautions need to be taken. Prevent accidents. After depressurizing and bringing to room temperature, release the sight glass from its housing and dismantle.

Unscrew the nuts (8) or screws (5), remove the washers (6) and release the cover (2). Remove the seals (3) and the glass (4). Clean the housing.

Position the new glass (4) with seals above and below (3). Insert the cover (2), place the washers (6) and tighten the nuts (8) or screws (5) to their tightening torque.

MODEL		265				365					
R1		1/2"	3/4"	1"	1/2"	3/4"	1"	1 1/4"	1 1/2"	2"	
CONNECTIONS		Female Gas Whitworth cylindrical thread ISO 228/1 (DIN-259)									
		NPT thread, ASME B1.20.1									
		Ends for welding SW ASME B16.11									
H		39,00	45,00	57,00	39,00	45,00	57,00	62,00	75,50	92,50	
h		20	25	30							
h ₁		60,00	66,00	87,00	60,00	66,00	87,00	92,00	110,00	130,00	
L		85	95	105	85	95	105	105	120	140	
WEIGHT IN kgs.		1,42	2,32	3,60	1,58	2,59	3,80	4,92	7,35	11,53	
CODE 2101-	CARBON STEEL	GAS	265.8024	265.8344	265.8104	365.8024	365.8344	365.8104	365.8144	365.8124	365.8204
		NPT	265.80241	265.83441	265.81041	365.80241	365.83441	365.81041	365.81441	365.81241	365.82041
		SW	265.80242	265.83442	265.81042	365.80242	365.83442	365.81042	365.81442	365.81242	365.82042
	STAINLESS STEEL	GAS	265.8022	265.8342	265.8102	365.8022	365.8342	365.8102	365.8142	365.8122	365.8202
		NPT	265.50221	265.83421	265.81021	365.80221	365.83421	365.81021	365.81421	365.81221	365.82021
		SW	265.50222	265.83422	265.81022	365.80222	365.83422	365.81022	365.81422	365.81222	365.82022

MODEL		366																							
DN		15				20				25				32				40				50			
CONNECTIONS		I - Flanges PN-16 EN-1092-1																							
		II - Flanges PN-40 EN-1092-1																							
		III - Flanges class 150 lbs ASME B 16.5																							
		IV - Flanges class 300 lbs ASME B 16.5																							
		I	II	III	IV	I	II	III	IV	I	II	III	IV	I	II	III	IV	I	II	III	IV	I	II	III	IV
H		39,00				45,00				57,00				62,00				75,50				92,50			
h ₁		60,00				66,00				87,00				92,00				110,50				130,00			
L		130				150				160				180				200				230			
D		95	95	90	95	105	105	100	115	115	115	110	125	140	140	115	135	150	150	125	155	165	165	150	165
K		65,00	65,00	60,30	66,70	75,00	75,00	69,90	82,60	85,00	85,00	79,40	88,90	100,00	100,00	88,90	98,40	110,00	110,00	98,40	114,30	125,00	125,00	120,70	127,00
I		14,00	14,00	15,90	15,90	14,00	14,00	15,90	19,10	14,00	14,00	15,90	19,10	18,00	18,00	15,90	19,10	18,00	18,00	15,90	22,20	18,00	18,00	19,10	19,10
b		16,00	16,00	11,20	14,30	18,00	18,00	12,70	15,90	18,00	18,00	14,30	17,50	18,00	18,00	15,90	19,10	18,00	18,00	17,50	20,70	18,00	18,00	19,10	22,30
DRILLS N°.		4				4				4				4				4				8			
WEIGHT IN kgs.		3,06				4,69				6,60				9,07				12,00				18,00			
CODE 2101-366.	CARBON STEEL	5024	8024	50241	80241	5344	8344	53441	83441	5104	8104	51041	81041	5144	8144	51441	81441	5124	8124	51241	81241	5204	8204	52041	82041
	STAINLESS STEEL	5022	8022	50221	80221	5342	8342	53421	83421	5102	8102	51021	81021	5142	8142	51421	81421	5122	8122	51221	81221	5022	8202	52021	82021

MODEL		366																							
DN		65				80				100				125				150				200			
CONNECTIONS		I - Flanges PN-16 EN-1092-1																							
		II - Flanges PN-40 EN-1092-1																							
		III - Flanges class 150 lbs ASME B 16.5																							
		IV - Flanges class 300 lbs ASME B 16.5																							
		I	II	III	IV	I	II	III	IV	I	II	III	IV	I	II	III	IV	I	II	III	IV	I	II	III	IV
H		109,00				116,50				125,50				141,00				160,00				196,00			
h ₁		128,00				135,50				144,50				163,00				182,00				218,00			
L		290				310				350				400				480				600			
D		185	185	180	190	200	200	190	210	220	235	230	255	250	270	255	280	285	300	280	320	340			
K		145,00	145,00	139,70	149,20	160,00	160,00	152,4	168,30	180,00	190,00	190,50	200,00	210,00	220,00	215,90	235,00	240,00	250,00	241,30	269,90	295,00			345
I		18,00	18,00	19,10	22,20	18,00	18,00	19,10	22,20	18,00	22,00	19,10	22,20	18,00	26,00	22,20	22,20	22,00	26,00	22,20	22,20	22,00			22,20
b		18,00	22,00	22,30	25,40	20,00	24,00	23,90	28,60	20,00	24,00	23,90	31,80	22,00	26,00	23,90	35,00	22,00	28,00	25,40	36,60	24,00			28,60
DRILLS N°.		8	8	4	8	8	8	4	8	8	8	8	8	8	8	8	8	8	8	12	12	12			8
WEIGHT IN kgs.		18,15				20,20				31,53				45,19				64,37				110,80			
CODE 2101-366.	CARBON STEEL	5224	8224	52241	82241	5304	8304	53041	83041	5404	8404	54041	84041	5504	8504	55041	85041	5604	8604	56041	86041	5804			58041
	STAINLESS STEEL	5222	8222	52221	82221	5302	8302	53021	83021	5402	8402	54021	84021	5502	8502	55021	85021	5602	8602	56021	86021	5802			58021