

ACTUATORS

MANUAL PNEUMATIC D/A ELECTRIC

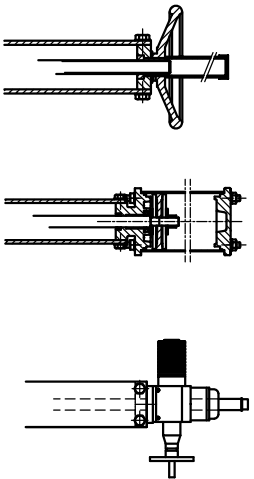

MODEL	SOFT SEAT	BORE			DIMENSIONS		FLANGE DIMENSIONS					
		MM	A	DxD	Y n°div=Z	Ø	d	N°	Thread	e	N°	
125x125	93	107	80	215x215	2x92,5=185	12	7	M10	1	1		
150x150	118	132	80	240x240	2x105=210	12	7	M10	1	1		
200x200	168	182	80	290x290	2x130=260	12	7	M10	1	1		
250x250	218	232	80	340x340	2x155=310	12	7	M10	1	1		
300x300	268	282	80	390x390	3x120=360	12	10	M10	2	2		
350x350	318	330	100	450x450	3x140=420	14	10	M12	2	2		
400x400	368	380	100	500x500	4x117,5=470	14	13	M12	3	3		
450x450	418	430	100	550x550	4x130=520	14	13	M12	3	3		
500x500	468	480	100	600x600	4x142,5=570	14	13	M12	3	3		
550x550	518	530	100	650x650	4x155=620	14	13	M12	3	3		
600x600	568	580	100	700x700	4x167,5=670	14	13	M12	3	3		
650x650	618	630	100	750x750	4x180=720	14	13	M12	3	3		
700x700	668	680	120	810x810	5x155=775	16	16	M14	4	4		
750x750	718	730	120	860x860	5x166=830	16	16	M14	4	4		
800x800	768	780	120	910x910	5x175=875	16	16	M14	4	4		
900x900	868	880	140	1010x1010	6x162,5=975	18	18	M16	6	6		
1000x1000	968	980	140	1120x1120	7x155=1085	18	20	M16	6	6		

MODEL	DIMENSIONS	MANUAL		PNEUMATIC		ELECTRIC	
		ØSTEM	HANDWHEEL	ØCYLINDER	ØSTEM	COUPLING	PAR m/kg
125x125	Ø25x5	Ø300	Ø80	Ø20	F10	30	SA07.2
150x150	Ø25x5	Ø300	Ø80	Ø20	F10	30	SA07.2
200x200	Ø25x5	Ø300	Ø80	Ø20	F10	30	SA07.2
250x250	Ø25x5	Ø300	Ø80	Ø20	F10	60	SA07.6
300x300	Ø25x5	Ø300	Ø80	Ø20	F10	60	SA07.6
350x350	Ø25x5	Ø300	Ø100	Ø20	F10	60	SA07.6
400x400	Ø25x5	Ø300	Ø125	Ø25	F10	60	SA07.6
450x450	Ø25x5	Ø300	Ø125	Ø25	F10	120	SA10.2
500x500	Ø25x5	Ø300	Ø160	Ø30	F10	120	SA10.2
550x550	Ø25x5	Ø300	Ø160	Ø30	F10	120	SA10.2
600x600	Ø36x6	Ø400	Ø160	Ø30	F10	120	SA10.2
650x650	Ø36x6	Ø400	Ø160	Ø30	F10	120	SA10.2
700x700	Ø36x6	Ø400	Ø200	Ø30	F10	120	SA10.2
750x750	Ø36x6	Ø400	Ø200	Ø30	F10	120	SA10.2
800x800	Ø40x7	Ø500	Ø200	Ø30	F10	120	SA10.2
900x900	Ø40x7	Ø500	Ø250	Ø40	F10	120	SA10.2
1000x1000	Ø40x7	Ø500	Ø250	Ø40	F10	120	SA10.2

*Higher dimensions under request

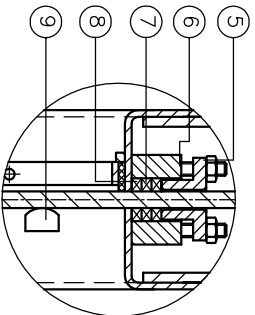
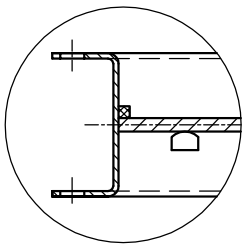
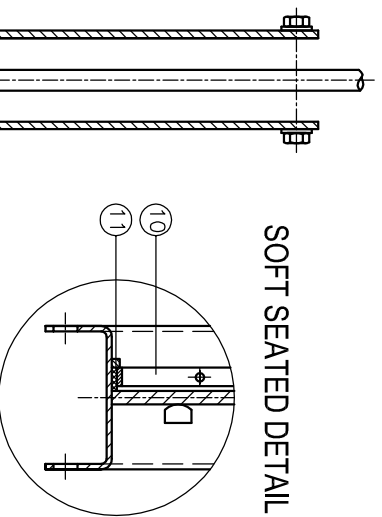
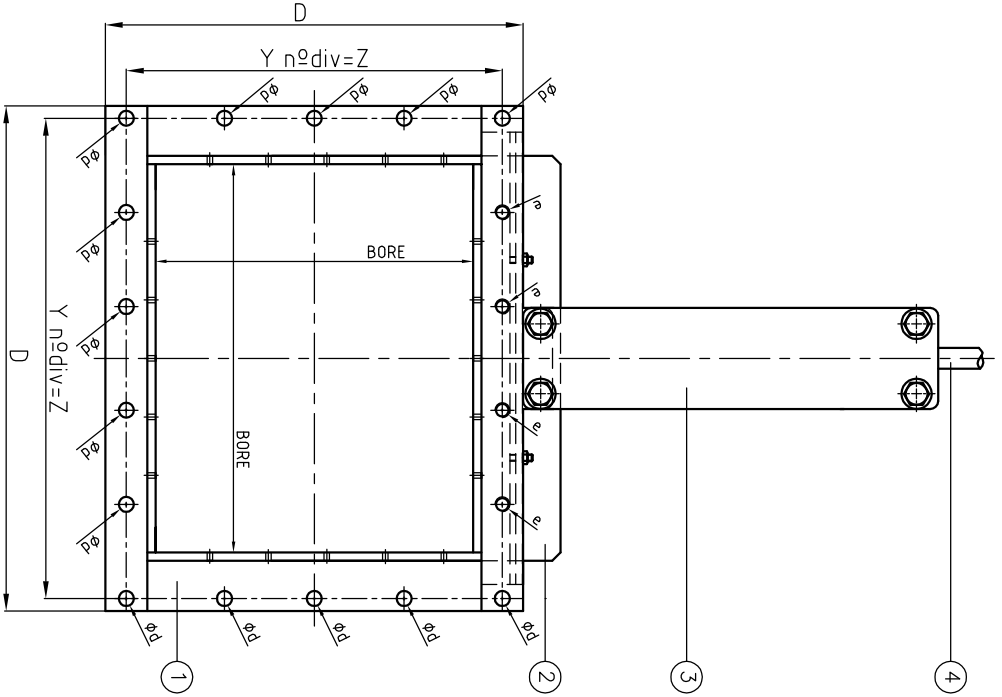

* Consult material.

Bolting	A2
Seat	EPDM/NBR/VITON/SILICONE
Fixing plate	SS304L/SS316L
Wedge	Ertacetal*
Packing o'ring	SYNT+PTFE
Toric joint	EPDM/NBR/VITON/SILICONE
Packing	Steel/SS304L/SS316L
Packing gland	Steel/SS304L/SS316L
Stem	SS303*
Support plate	Steel/SS304L/SS316L
Gate	SS304L/SS316L
Body	Steel/SS304L/SS316L

VÁLVALAS ZUBI S.L. C/AUZOLAN 2-B (Baño) 20303 IRÚN TELEF.(943)635271 FAX(943)635193

Square model
Square gate valve

ZUBI reserves the right to modify the measures without previous notice