

**Description:**

The HQ008 to HQ120 electric actuators are specially designed for quarter turn applications such as ball, butterfly, plug valves and dampers. With a wide range of output torques and control options the HQ series electric actuator can be configured to meet the demands of any site specification. High quality electrical components, alloy gearing and a high pressure die cast aluminium housing ensure reliability and extended life span.

**Standard Specification:**

- Enclosure : Weatherproof IP67 (IP68 Option)
- Power Supply : 110/220v 50/60Hz, 24vAC/DC, 380/440V 3Phase
- Duty Cycle (On/Off Duty) : S4, 70% Standard, 100% for max 30 mins
- Motor : Squirrel Caged Induction Motor
- Limit Switches : 4 x SPDT, 250V AC 10A
- Torque Switches : 2 x SPDT, 250vAC 10A (HQ015-HQ120)
- Space Heater : 10W(110/220VAC) Anti Condensation
- Conduit Entries : 2 x M25 (PG13.5 OR 1/2"NPT OPTION)
- Travel Angle : 90° ± 5°
- Ambient Temperature : -20°C to +70°C On/Off, -20° to +55° Modulating
- External Coating : Hard Anodised before Dry Powder Polyester Coating

**Option Specification:**

- PIU : Potentiometer Unit (1K - 10K)
- PCU : Proportional Control Unit (In/Out: 0-10VDC, 4-20mA)
- CPT : Current Position Transmitter (Output 4-20mA)
- LCU-B : Local Control Unit (Remote/Open/Stop/Close switch)
- EXA : Explosion Proof Enclosure. ATEX II 2G Eexd IIB T4
- FPA : Fire Proof Actuator. 250°C/150 min
- RBP : Rechargeable Battery Back up for Fail Safe
- MRCT : Speed Control Card

**Performance:**

MODEL	HQ008	HQ015	HQ020	HQ030	HQ050	HQ060	HQ080	HQ120
TORQUE (Nm)	80	150	200	300	500	600	800	1200
SPEED 90° 50/60Hz	16/13	25/21	25/21	31/26	31/26	31/26	34/28	34/28
CURRENT (A)	110/1/50	1.2	2.1	2.2	2.4	4.2	5.7	6.9
	220/1/50	0.6	1	1.1	1.3	1.9	2	3
	380/3/50	0.2	0.6	0.7	0.6	0.9	1	1.3
MAX 24V AC/DC	3.7	5.3	6.5	8.6	-	7.0	8.6	8.6
WEIGHT (Kg)	7.4	16.6	16.6	22	23	23	29	29
MAX. SQ. DRIVE	17	19	19	30	30	30	40	40

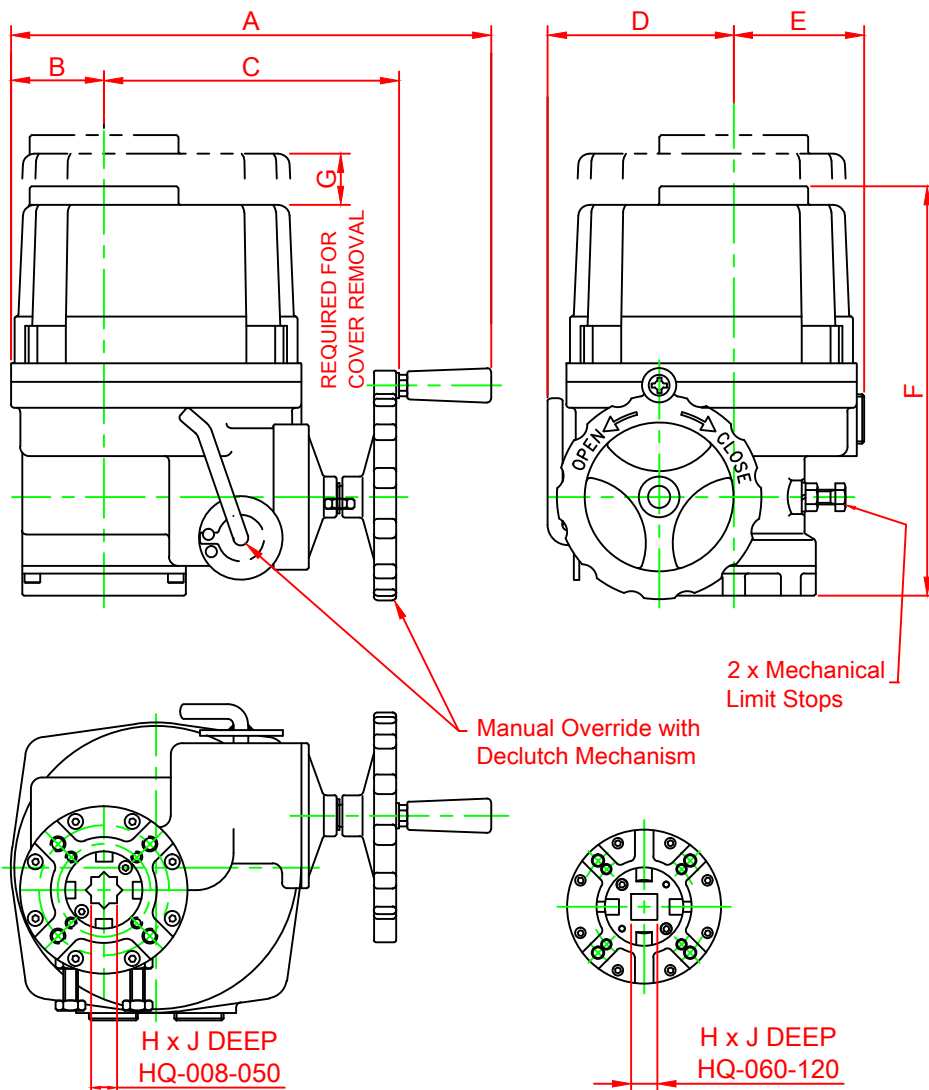

DRIVE BUSH CAN BE MACHINED TO SUIT MOST VALVE STEMS ( ON REQUEST)

**Dimensions:**

MODEL	BASE	A	B	C	D	E	F	G	H	J
HQ008	F07	258	50	157	100	70	235	120	14	40
HQ015	F07/F10	338	73	200	142	87	268	160	17	45
HQ020	F07/F10	338	73	200	142	87	268	160	17	45
HQ030	F10/F12	368	82	221	160	99	290	180	22	52
HQ050	F10/F12	368	82	221	160	99	290	180	22	52
HQ060	F10/F12	368	82	221	160	99	290	180	27	52
HQ080	F12/F14	410	103	242	186	111	330	210	27	60
HQ120	F12/F14	410	103	242	186	111	330	210	36	60

DATA SHEET No.

3.02

ISSUE DATE

AUG 2020

ISSUE REF

G