

XLC 400 - Standard version - Technical details

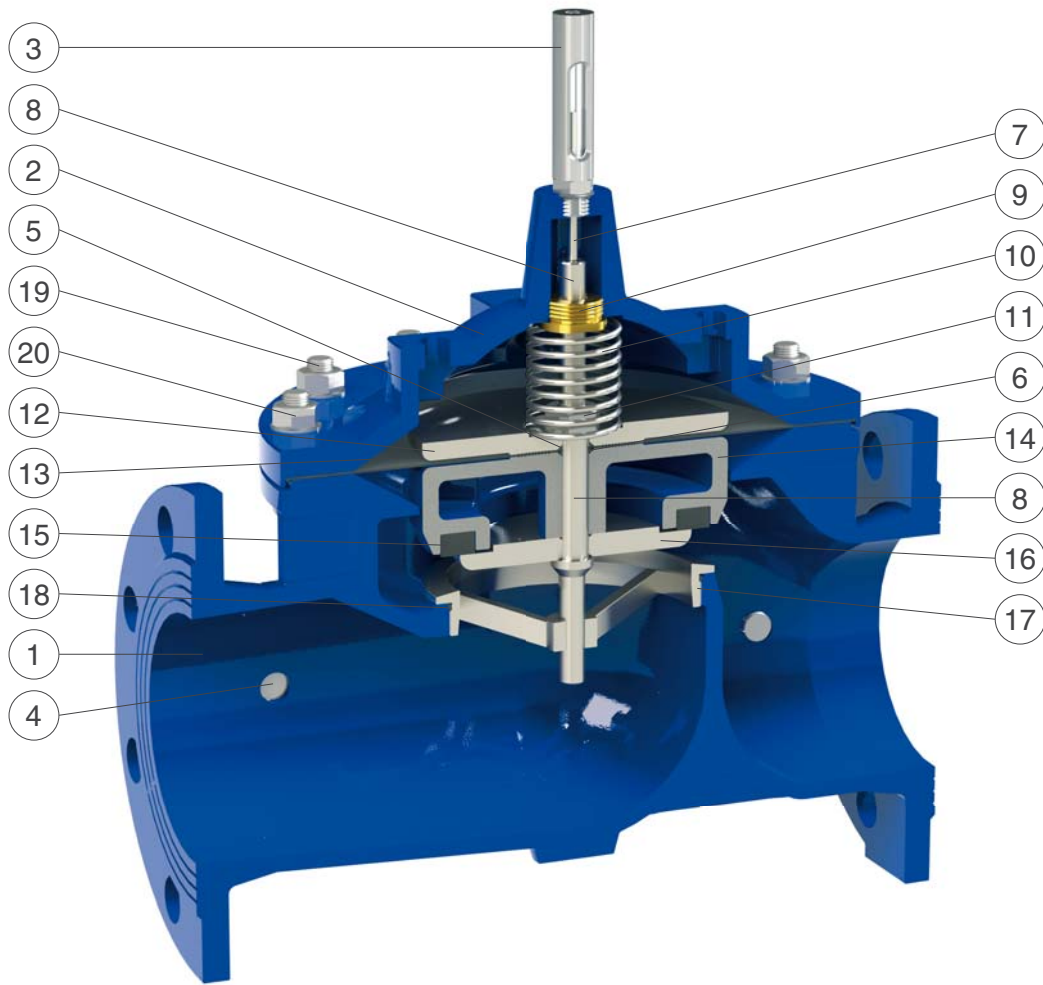

N.	Component	Standard material	Optional
1	Body	ductile cast iron GJS 500-7 or GJS 450-10	
2	Cap	ductile cast iron GJS 500-7 or GJS 450-10	
3	Position indicator	s.s. AISI 303 (nickel-plated brass from DN 300)	stainless steel AISI 303
4	Pressure outlet taps	stainless steel AISI 316	
5	Upper flat O-ring	NBR	EPDM/Viton
6	Obturator O-ring	NBR	EPDM/Viton
7	Indicator stem	stainless steel AISI 303	stainless steel AISI 316
8	Main shaft	stainless steel AISI 303	stainless steel AISI 316
9	Guide ring	bronze CuSn5Zn5Pb5	stainless s. AISI 304/316
10	Spring	stainless steel AISI 302	
11	Locking nut	stainless steel AISI 304	stainless steel AISI 316
12	Upper flat	painted steel	stainless s. AISI 304/316
13	Diaphragm	polyamide-Nylon	neoprene/EPDM-Nylon
14	Obturator	AISI 303 (DN 50-65), steel, duct. c. iron (from DN 150)	stainless s. AISI 304/316
15	Plane gasket	NBR	
16	Gasket holder	stainless steel AISI 303 (304 from DN 150)	stainless steel AISI 316
17	Seat	stainless steel AISI 303 (316 from DN 150)	stainless steel AISI 316
18	Seat O-ring	NBR	EPDM/Viton
19	Studs	stainless steel AISI 304	stainless steel AISI 316
20	Nuts and washers	stainless steel AISI 304	stainless steel AISI 316

The list of materials and components is subject to changes without notice.



XLC 400 - Standard version - Technical data

DN (mm)	40	50	65	80	100	150	200	250	300	400
Kv (m³/h)	40,6	40,6	68	100	169	410	662	1126	1504	2675
Stroke (mm)	15	15	18	21	27	43	56	70	84	110

Head loss coefficient

Kv coefficient representing the flow rate which is flowing through the valve fully open, and producing a head loss of 1 bar.

Cavitation chart

The cavitation analysis is very important since it may lead to substantial damages, in addition to vibration and noise. The cavitation chart has to be used to determine whether the working point obtained by the intersection of the lines, connecting upstream (y axis) and downstream (x axis) pressure conditions, lies within one of the 3 zones to be identified as follows:

- A: Recommended working conditions;
- B: Noise cavitation;
- C: Damage cavitation.

The chart is to be used for valves modulating with an opening percentage between 35-40% at standard water temperature and elevation below 300 m. For continuous pressure reduction the maximum allowed Δp shall not exceed 15 bar.

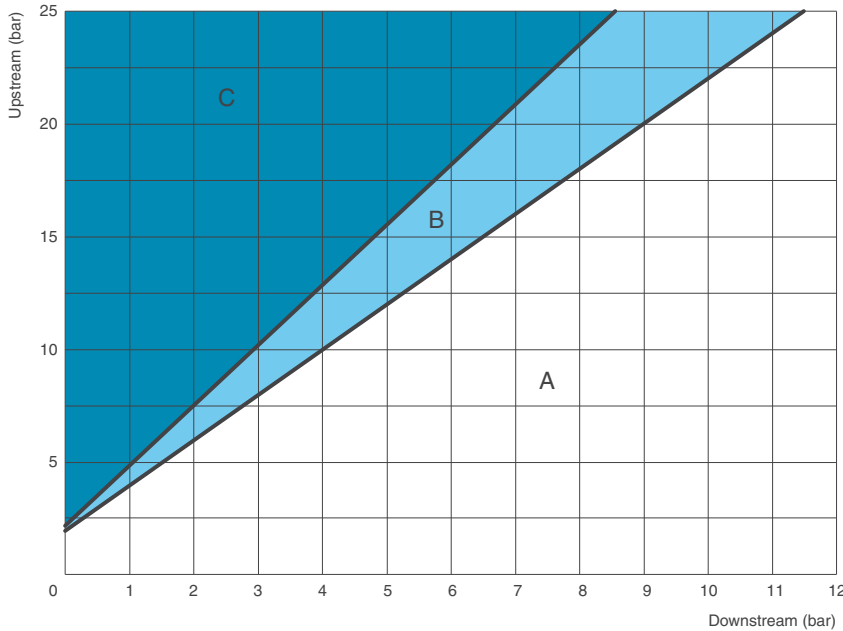

Head loss chart

The chart indicates the head loss of XLC 400 automatic control valves fully open versus flow rate in l/s.

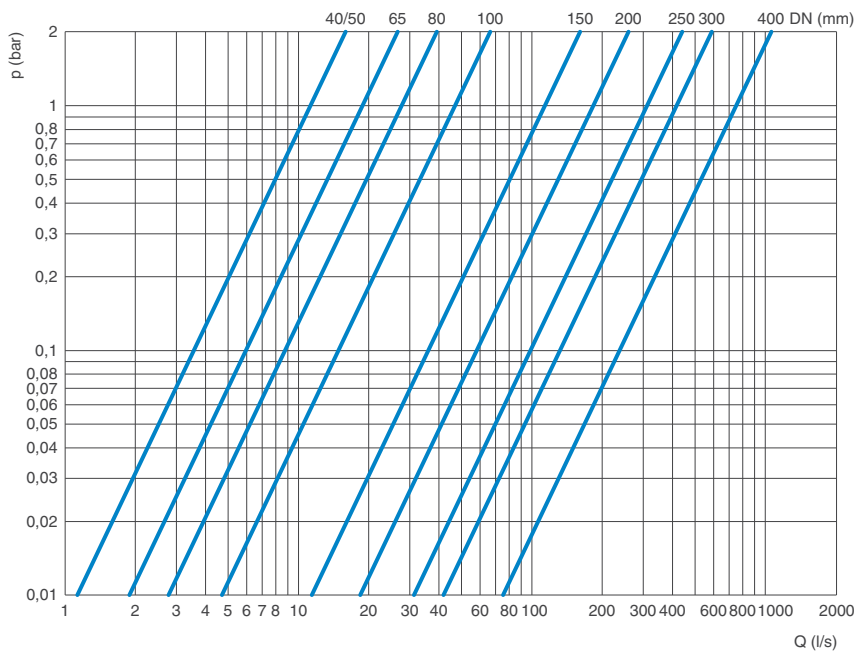

Recommended flow rate

The following chart shows the recommended flow rate for the proper sizing of XLC 400 control valves.

DN (mm)			40/50	65	80	100	150	200	250	300	400
Flow rate (l/s)	Low head loss (0,1-0,15 bar)	Max.	3,9	6,6	10	16	35	63	98	140	250
		Min.	1	1,7	2,5	3,9	8,8	16	25	35	63
	Recommended	Max.	9,8	17	25	39	88	157	245	353	628
		Pressure relief	Max.	15	25	38	59	132	235	368	530

All values are approximate, consult CSA service for more details.

XLC 400 - Standard and anti-cavitation versions - Technical data

Kv to valve opening chart

The following chart shows the opening percentage of XLC 400, XLC 400-AC and XLC 400-CP versus the Kv.

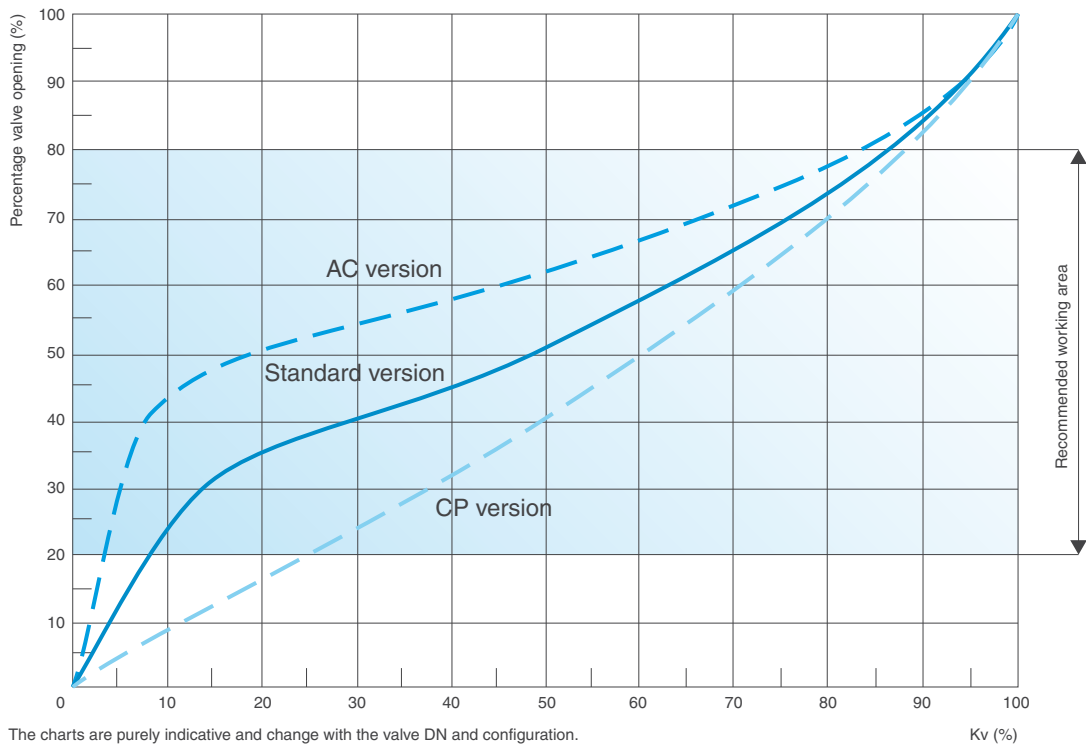

Working conditions

Treated filtered water.
 Maximum temperature: 70°C.
 Minimum pressure on the pilot : 0,5 bar plus head loss.
 Maximum pressure : 25 bar.

Standard

Certified and tested in compliance with EN 1074/5.
 Pressure rating 25 bar.
 Flanges according to EN 1092/2 (different drilling on request).
 Epoxy painting applied through FBT technology blue RAL 5005.

Weights and dimensions

DN (mm)	A (mm)	B (mm)	C (mm)	D (mm)	E (mm)	Weight (Kg)
40	230	162	83	235	30	18
50	230	162	83	235	30	18
65	290	194	93	275	30	23,5
80	310	218	100	295	30	28
100	350	260	118	335	30	39
150	480	370	150	450	30	84
200	600	444	180	495	30	138
250	730	570	213	600	40	264
300	850	676	242	720	40	405
400	1100	870	310	915	40	704

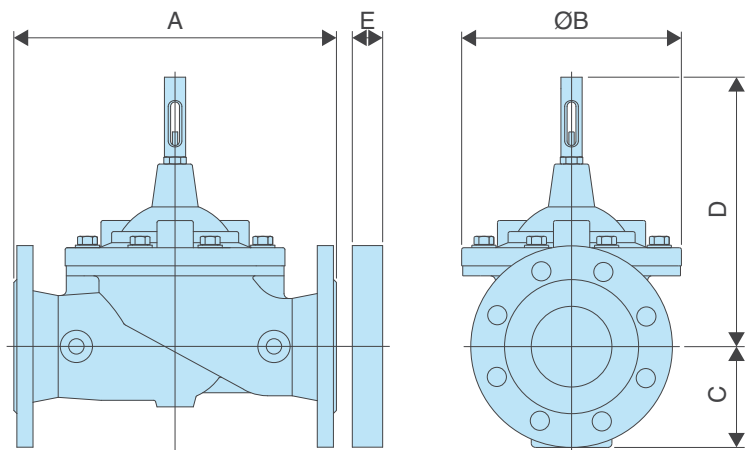

The dimension E in the picture above refers only to applications where it is necessary to add a flanged orifice downstream or upstream of the valve, for example for flow control or cavitation prevention.

All values are approximate, consult CSA service for more details.

XLC 400 - Standard and anti-cavitation versions - Spare parts breakdown

