

SERIES 3S/31 ANSI RANGE

Check Valves are self-acting valves used for preventing the reverse of flow in a piping system. Series 3S are Swing Check Valves that operate by means of its articulated disc. They are featured by its rugged and simple design and easy maintenance.

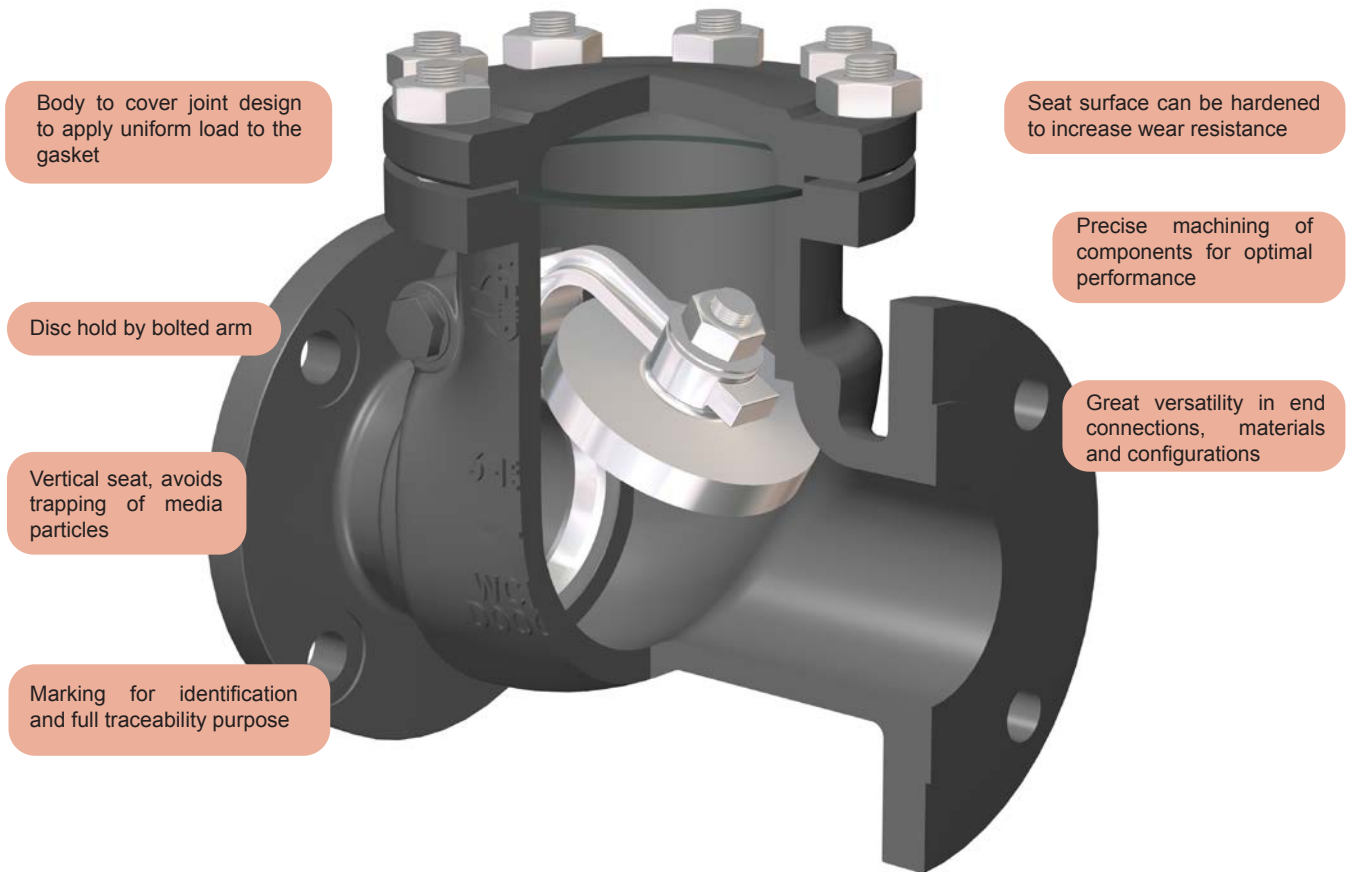

Body to cover joint design to apply uniform load to the gasket

Seat surface can be hardened to increase wear resistance

Disc hold by bolted arm

Precise machining of components for optimal performance

Vertical seat, avoids trapping of media particles

Great versatility in end connections, materials and configurations

Marking for identification and full traceability purpose

Main Features / Reference Standards

Design: API 6D / BS 1868
 Pressure Rating: 150/300/600/900/1500/2500#
 Face to face length: ASME B16.10
 Valve end connections: Flanged RF or RTJ to ASME B16.5 (size ≤ 24") / ASME B16.47 (size > 24")
 Welded BW to ASME B16.25
 Marking: MSS SP-25
 Inspections & Tests: API 598
 Primer painted grey color similar to RAL 7037 for protection during storage and transport (carbon steel body/bonnet)
 Product compliant with Directive 2014/68/EU on Pressure Equipment (PED) for European Union territory

Main Duties / Limits of use

Fluids compatible with materials of construction. Questions referring to chemical resistance, please consult us
 Pressure / Temperature Rating to ASME B16.34. See section "Engineering & Performance Data"
 For products compliant with Directive 2014/68/EU, observe also limits acc. to Annex II tables 6 & 8 (gases & liquids group 1*) and tables 7 & 9 (gases & liquids group 2*) up to category III
 *Classification of fluids (group 1 or 2) acc. to Directive 2014/68/EU, Article 13

Options

Diverse materials of construction and trim combinations, special designs, execution for aggressive atmosphere, etc.
 Please consult us

Main Parts and Materials

SERIES 3S ANSI RANGE
Class 150&300

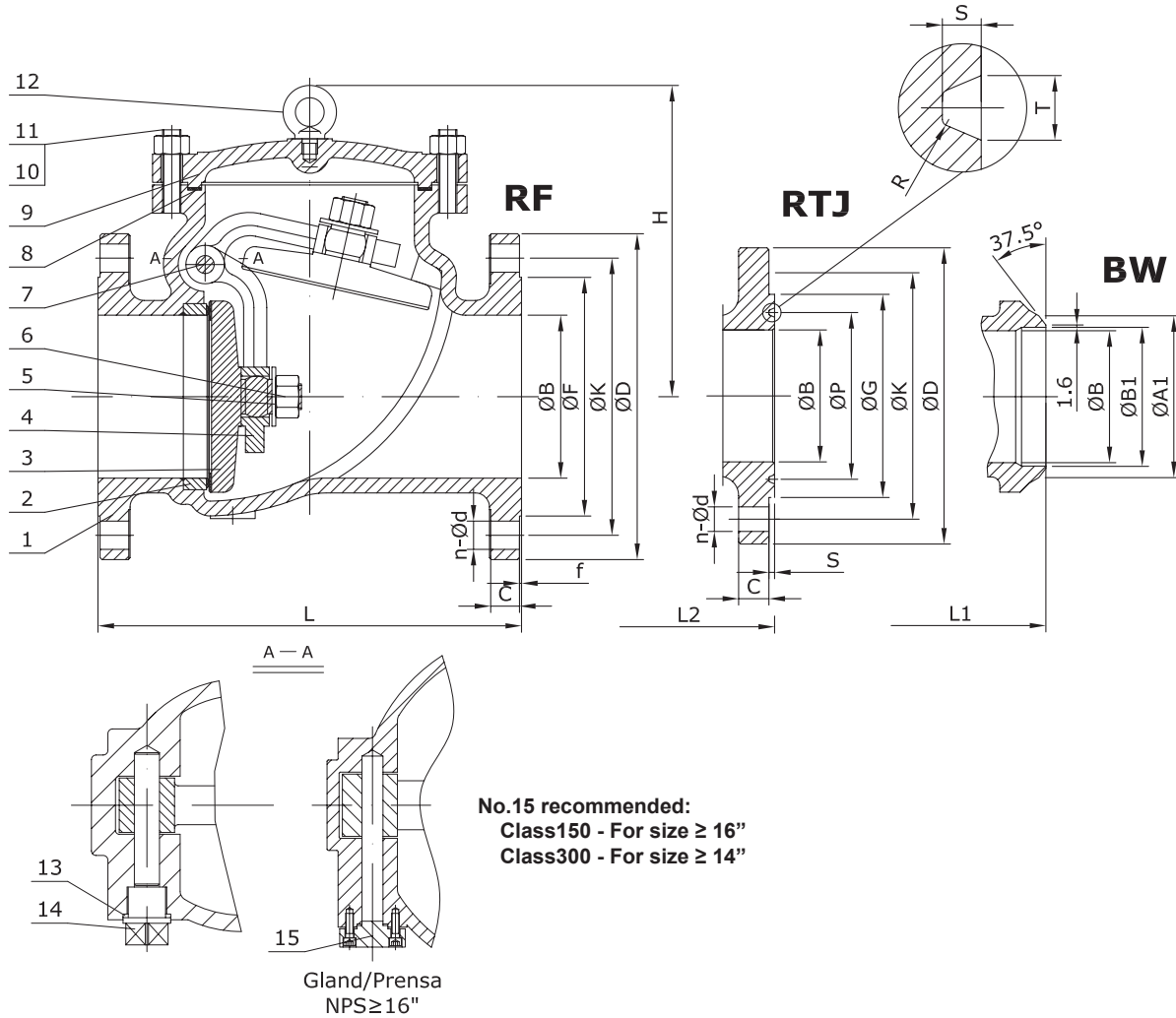

Nº	Part name	A216 WCB (3SA0_)	A352 LCB		A217 WC1 (3SB1_)	A217 WC6 (3SB8_)	A217 WC9 (3SB9_)	A217 C5 (3SC2_)	A217 C12 (3SC4_)
			Trim 2 (3SA82_)	Trim 12 (3SA8G_)					
1	Body	A216 WCB	A352 LCB		A217 WC1	A217 WC6	A217 WC9	A217 C5	A217 C12
2	Seat Ring	A105	A182 F304	A182 F316+HF	A182 F1+HF	A182 F11+HF	A182 F22+HF	A182 F5+HF	A182 F9+HF
3	Disc	A216 WCB	A351 CF8	A351 CF8M	A217 WC1+HF	A217 WC6+HF	A217 WC9+HF	A217 C5+HF	A217 C12+HF
4	Hinge	A216 WCB	A352 LCB		A217 WC1	A217 WC6	A217 WC9	A217 C5	A217 C12
5	Washer	SS304	SS304	SS316	SS304		SS304		
6	Disc Nut	A194 2H	A194 4		A194 4		A194 4		
7	Hinge Pin	A182 F6a	A182 F304	A182 F316	A182 F6a		A182 F6a		
8	Gasket	SS304 +Graphite	SS304 +Graphite	SS316 +Graphite	SS304 +Graphite		SS304 +Graphite		
9	Cover	A216 WCB	A352 LCB		A217 WC1	A217 WC6	A217 WC9	A217 C5	A217 C12
10	Cover Bolt	A193 B7	A320 L7		A193 B16		A193 B16		
11	Cover Nut	A194 2H	A194 4		A194 4		A194 4		
12	Eye Bolt	Carbon Steel	Carbon Steel		Carbon Steel		Carbon Steel		
13	Gasket	SS304	SS304	SS316	SS304		SS304		
14	Plug	A105	A350 LF2		A182 F1	A182 F11	A182 F22	A182 F5	A182 F9
15	Gland	A105	A350 LF2		A182 F1	A182 F11	A182 F22	A182 F5	A182 F9

Fig. 3SA0_	Seat Surface	Disc Surface
TRIM #1 (3SA01)	A105+13Cr	A216 WCB+13Cr
TRIM #5 (3SA05)	A105+HF	A216 WCB+HF
TRIM #8 (3SA08)	A105+HF	A216 WCB+13Cr

HF = Hard faced

Main Parts and Materials

SERIES 3S ANSI RANGE
Class 150&300

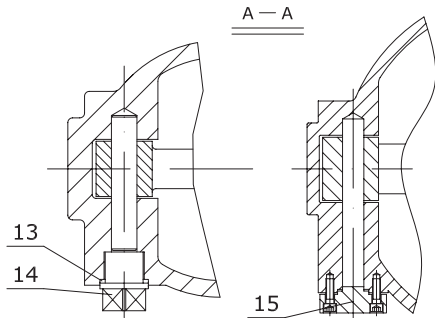
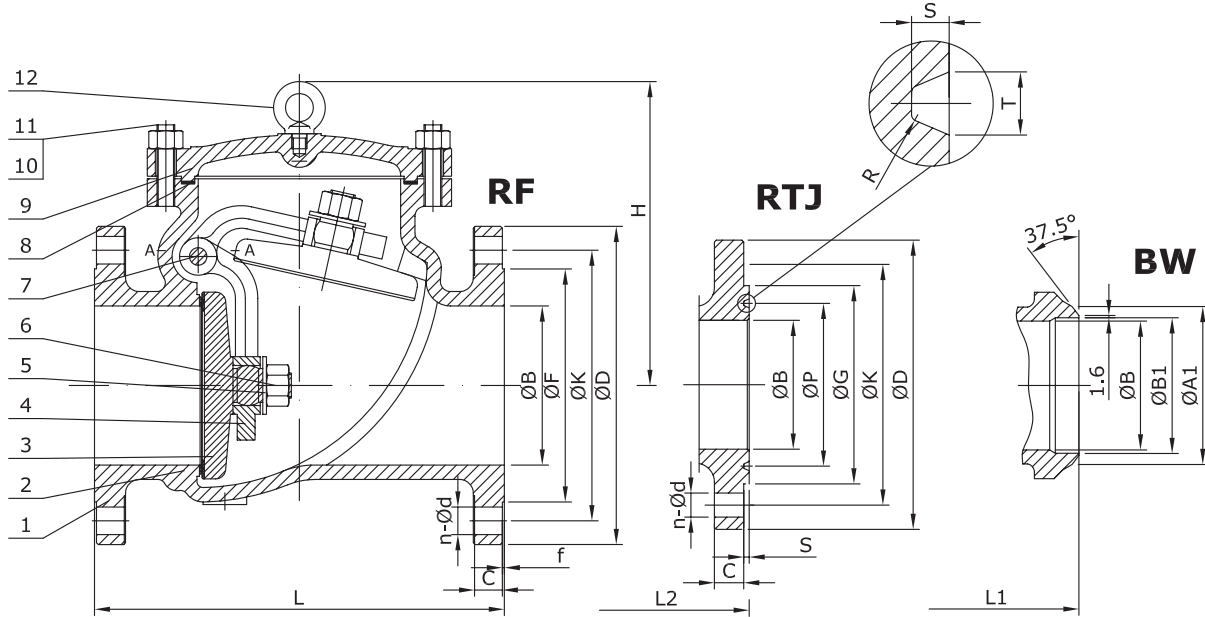

No.15 recommended:
Class150 - For size ≥ 16"
Class300 - For size ≥ 14"

Gland/Prensa
NPS ≥ 16"

Nº	Part name	CF8 (3SI2_)	CF8M (3SI0_)	CF3 (3SI1_)	CF3M (3SI7_)
1	Body	A351 CF8	A351 CF8M	A351 CF3	A351 CF3M
2	Seat Ring	Integral SS304	Integral+HF	Integral SS304L	Integral+HF
3	Disc	A351 CF8	A351 CF8M	A351 CF3	A351 CF3M
4	Hinge	A351 CF8	A351 CF8M	A351 CF3	A351 CF3M
5	Washer	SS304	SS316	SS304L	SS316L
6	Disc Nut	A194 8	A194 8M	A194 8M	
7	Hinge Pin	A182 F304	A182 F316	A182 F304L	A182 F316L
8	Gasket	SS304+Graphite	SS316+Graphite	SS316+Graphite	SS316L+Graphite
9	Cover	A351 CF8	A351 CF8M	A351 CF3	A351 CF3M
10	Cover Bolt	A193 B8	A193 B8M	A193 B8M	
11	Cover Nut	A194 8	A194 8M	A194 8M	
12	Eye Bolt	Carbon Steel		Carbon Steel	
13	Gasket	SS304	SS316	SS304L	SS316L
14	Plug	A182 F304	A182 F316	A182 F304L	A182 F316L
15	Gland	A182 F304	A182 F316	A182 F304L	A182 F316L

Main Valve Parameters - Class 150

SERIES 3S ANSI RANGE

Nominal Size		inch	2"	2-1/2"	3"	4"	5"	6"	8"	10"	12"	14"
DN			50	65	80	100	125	150	200	250	300	350
End connection	RF	L	203	216	241	292	330	356	495	622	698	787
		ØB	51	65,375	76	102	128,25	152	203	254	305	337
		ØD	150	180	190	230	255	280	345	405	485	535
		ØK	120,7	139,7	152,4	190,5	215,9	241,3	298,5	362	431,8	476,3
		ØF	92,1	104,8	127	157,2	185,7	215,9	269,9	323,8	381	412,8
		C	14,3	15,9	17,5	22,3	22,3	23,9	27	28,6	30,2	33,4
		f	2	2	2	2	2	2	2	2	2	2
		n-Ød	4 - 3/4	4 - 3/4	4 - 3/4	8 - 3/4	8 - 7/8	8 - 7/8	8 - 7/8	12 - 1	12 - 1	12 - 1 1/8
	BW	L1	203	216	241	292	330	356	495	622	698	787
		Schedule No.(1)	40	-	40	40	-	40	40	40	STD	STD
		ØB	51	65,375	76	102	128,25	152	203	254	305	337
		ØA1	60,3	-	91	117	-	172	223	278	329	362
		ØB1	52,48	-	78	102	-	154	203	254,5	305	336,5
	RTJ	L2	216	229	254	305	343	369	508	635	711	800
		ØB	51	65,375	76	102	128,25	152	203	254	305	337
		ØD	150	180	190	230	255	280	345	405	485	535
		ØK	120,7	139,7	152,4	190,5	215,9	241,3	298,5	362	431,8	476,3
		ØG	102	121	133	171	194	219	273	330	406	425
		ØP	82,55	101,6	114,3	149,23	171,45	193,68	247,65	304,8	381	396,88
		C	17,5	20,7	22,3	22,3	22,3	23,9	27	28,6	30,2	33,4
		n-Ød	4 - 3/4	4 - 3/4	4 - 3/4	8 - 3/4	8 - 7/8	8 - 7/8	8 - 7/8	12 - 1	12 - 1	12 - 1 1/8
		T	8,74	8,74	8,74	8,74	8,74	8,74	8,74	8,74	8,74	8,74
		S	6,35	6,35	6,35	6,35	6,35	6,35	6,35	6,35	6,35	6,35
	R	0,8	0,8	0,8	0,8	0,8	0,8	0,8	0,8	0,8	0,8	
	H		127	144	156	177	210	235	340	410	456	475
	Kvs-value		86	177	244	444	801	1064	1949	3051	4530	5556
	Approx. Weight RF (2)		13	19	23	36	51	62	115	180	275	351
	Approx. Weight BW		10	14	18	28	40	49	93	151	231	295

(1) Other schedule nos. on request
 (2) RTJ weight increases approx. by 10%

Dimensions in mm (except for bolt holes - Ød -, which are in inch units) subject to manufacturing tolerance
 Kvs-values in m³/h / Weights in kg
 For more information about flanged and welded ends refer to page 16

Main Valve Parameters - Class 150

SERIES 3S ANSI RANGE



Nominal Size		inch	16"	18"	20"	24"	26"	28"	30"	32"	36"	
DN			400	450	500	600	650	700	750	800	900	
End connection	RF	L	914	978	978	1295	1295	1448	1524	1727 (3)	1956	
		ØB	387	438	489	591	633	684	735	779	874	
		ØD	595	635	700	815	870	925	985	1060	1170	
		ØK	539,8	577,9	635	749,3	806,4	863,6	914,4	977,9	1085,8	
		ØF	469,9	533,4	584,2	692,2	749	800	857	914	1022	
		C	35	38,1	41,3	46,1	66,7	69,9	73,1	79,4	88,9	
		f	2	2	2	2	2	2	2	2	2	
		n-Ød	16 - 1 1/8	16 - 1 1/4	20 - 1 1/4	20 - 1 3/8	24 - 1 3/8	28 - 1 3/8	28 - 1 3/8	28 - 1 3/8	28 - 1 5/8	32 - 1 5/8
	BW	L1	914	978	978	1295	1295	1448	1524	1727 (3)	1956	
		Schedule No.(1)	STD	STD	STD	STD	20	20	20	20	20	
		ØB	387	438	489	591	633	684	735	779	874	
		ØA1	413	464	516	619	670	721	772	825	927	
		ØB1	387,5	438	489	590,5	635	686	736,5	787,5	889	
	RTJ	L2	927	991	991	1308	-	-	-	-	-	
		ØB	387	438	489	591	633	684	735	779	874	
		ØD	595	635	700	815	870	925	985	1060	1170	
		ØK	539,8	577,9	635	749,3	806,4	863,6	914,4	977,9	1085,8	
		ØG	483	546	597	711	810	861	917	984	1092	
		ØP	454,03	517,53	558,8	673,1	749,3	800,1	857,25	914,4	1022,35	
		C	35	38,1	41,3	46,1	66,7	69,9	73,1	79,4	88,9	
		n-Ød	16 - 1 1/8	16 - 1 1/4	20 - 1 1/4	20 - 1 3/8	24 - 1 3/8	28 - 1 3/8	28 - 1 3/8	28 - 1 3/8	28 - 1 5/8	32 - 1 5/8
		T	8,74	8,74	8,74	8,74	19,84	19,84	19,84	23,01	23,01	
		S	6,35	6,35	6,35	6,35	12,7	12,7	12,7	14,27	14,27	
	R	0,8	0,8	0,8	0,8	1,5	1,5	1,5	1,5	1,5		
	H		552	572	660	740	785	838	889	1012	1090	
	Kvs-value		7363	9829	12222	17833	21509	25225	28983	36863	52624	
	Approx. Weight RF (2)		460	575	740	1350	1800	2350	2650	3000	3690	
	Approx. Weight BW		390	498	648	1208	1628	2128	2411	2694	3250	

- (1) Other schedule nos. on request
- (2) RTJ weight increases approx. by 10%
- (3) Acc. to manufacturer standard

Dimensions in mm (except for bolt holes - Ød -, which are in inch units) subject to manufacturing tolerance
 Kvs-values in m³/h / Weights in kg
 For more information about flanged and welded ends refer to page 16

Main Valve Parameters - Class 300

SERIES 3S ANSI RANGE



Nominal Size		inch	2"	2-1/2"	3"	4"	5"	6"	8"	10"	12"
DN			50	65	80	100	125	150	200	250	300
End connection	RF	L	267	292	318	356	400	444	533	622	711
		ØB	51	65,375	76	102	128,25	152	203	254	305
		ØD	165	190	210	255	280	320	380	445	520
		ØK	127	149,2	168,3	200	235	269,9	330,2	387,4	450,8
		ØF	92,1	104,8	127	157,2	185,7	215,9	269,9	323,8	381
		C	20,7	23,9	27	30,2	33,4	35	39,7	46,1	49,3
		f	2	2	2	2	2	2	2	2	2
		n-Ød	8 - 3/4	8 - 7/8	8 - 7/8	8 - 7/8	8 - 7/8	12 - 7/8	12 - 1	16 - 1 1/8	16 - 1 1/4
	BW	L1	267	292	318	356	400	444	533	622	711
		Schedule No.(1)	40	-	40	40	-	40	40	40	STD
		ØB	51	65,375	76	102	128,25	152	203	254	305
		ØA1	60,3	-	91	117	-	172	223	278	329
		ØB1	52,48	-	78	102	-	154	203	254,5	305
	RTJ	L2	283	308	334	372	416	460	549	638	727
		ØB	51	65,375	76	102	128,25	152	203	254	305
		ØD	165	190	210	255	280	320	380	445	520
		ØK	127	149,2	168,3	200	235	269,9	330,2	387,4	450,8
		ØG	108	127	146	175	210	241	302	356	413
		ØP	82,55	101,6	123,83	149,23	180,98	211,12	269,88	323,85	981
		C	20,7	23,9	27	30,2	33,4	35	39,7	46,1	49,3
		n-Ød	8 - 3/4	8 - 7/8	8 - 7/8	8 - 7/8	8 - 7/8	12 - 7/8	12 - 1	16 - 1 1/8	16 - 1 1/4
		T	11,91	11,91	11,91	11,91	11,91	11,91	11,91	11,91	11,91
		S	7,92	7,92	7,92	7,92	7,92	7,92	7,92	7,92	7,92
		R	0,8	0,8	0,8	0,8	0,8	0,8	0,8	0,8	0,8
	H		137	162	180	205	268	315	370	430	465
	Kvs-value		86	177	244	440	799	1064	1953	3056	4568
	Approx. Weight RF (2)		17	27	34	55	83	104	176	258	420
Approx. Weight BW		12	20	26	42	64	81	140	209	346	

(1) Other schedule nos. on request
 (2) RTJ weight increases approx. by 10%

Dimensions in mm (except for bolt holes - Ød -, which are in inch units) subject to manufacturing tolerance
 Kvs-values in m³/h / Weights in kg
 For more information about flanged and welded ends refer to page 16

Main Valve Parameters - Class 300

SERIES 3S ANSI RANGE



Nominal Size		inch	14"	16"	18"	20"	24"	26"	28"	30"	32"
DN			350	400	450	500	600	650	700	750	800
End connection	RF	L	838	864	978	1016	1346	1346	1499	1594	1727 (3)
		ØB	337	387	432	483	584	633	684	735	779
		ØD	585	650	710	775	915	970	1035	1090	1150
		ØK	514,4	571,5	628,6	685,8	812,8	876,3	939,8	997	1054,1
		ØF	412,8	469,9	533,4	584,2	692,2	749	800	857	914
		C	52,4	55,6	58,8	62	68,3	77,8	84,2	90,5	96,9
		f	2	2	2	2	2	2	2	2	2
		n-Ød	20 - 1 1/4	20 - 1 3/8	24 - 1 3/8	24 - 1 3/8	24 - 1 5/8	28 - 1 3/4	28 - 1 3/4	28 - 1 7/8	28 - 2
	BW	L1	838	864	978	1016	1346	1346	1499	1594	1727 (3)
		Schedule No.(1)	STD	STD	STD	STD	STD	20	20	20	20
		ØB	337	387	432	483	584	633	684	735	779
		ØA1	362	413	464	516	619	670	721	772	825
		ØB1	336,5	387,5	438	489	590,5	635	686	736,5	787,5
	RTJ	L2	854	880	994	1035	1368	1374	1524	1619	1755
		ØB	337	387	432	483	584	633	684	735	779
		ØD	585	650	710	775	915	970	1035	1090	1150
		ØK	514,4	571,5	628,6	685,8	812,8	876,3	939,8	997	1054,1
		ØG	457	508	575	635	749	810	861	917	984
		ØP	419,1	469,9	533,4	584,2	692,15	749,3	800,1	857,25	914,4
		C	52,4	55,6	58,8	62	68,3	77,8	84,2	90,5	96,9
		n-Ød	20 - 1 1/4	20 - 1 3/8	24 - 1 3/8	24 - 1 3/8	24 - 1 5/8	28 - 1 3/4	28 - 1 3/4	28 - 1 7/8	28 - 2
		T	11,91	11,91	11,91	13,49	16,66	19,84	19,84	19,84	23,01
		S	7,92	7,92	7,92	9,53	11,13	12,7	12,7	12,7	14,27
	R	0,8	0,8	0,8	1,5	1,5	1,5	1,5	1,5	1,5	
	H		505	554	620	680	770	770	889	977	1016
	Kvs-value		5564	7368	9534	11910	17453	21368	24573	28983	36094
	Approx. Weight RF (2)		516	780	1150	1350	2100	2600	2900	3200	4900
	Approx. Weight BW		415	647	984	1145	1804	2254	2492	2713	4338

- (1) Other schedule nos. on request
- (2) RTJ weight increases approx. by 10%
- (3) Acc. to manufacturer standard

Dimensions in mm (except for bolt holes - Ød -, which are in inch units) subject to manufacturing tolerance
 Kvs-values in m³/h / Weights in kg
 For more information about flanged and welded ends refer to page 16

Main Parts and Materials

SERIES 3S ANSI RANGE
Class 600

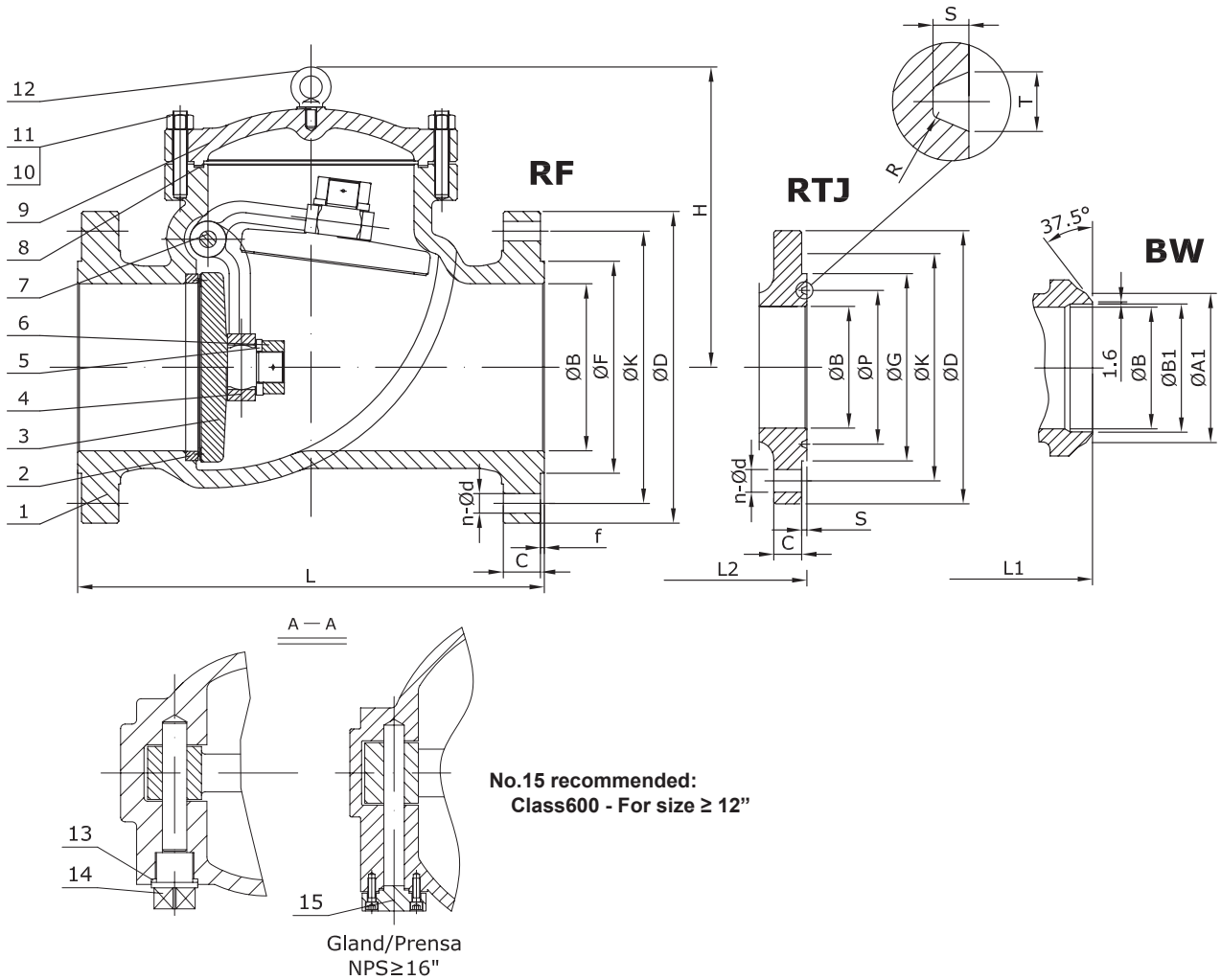

Nº	Part name	A216 WCB (3SA0_)	A352 LCB		A217 WC1 (3SB1_)	A217 WC6 (3SB8_)	A217 WC9 (3SB9_)	A217 C5 (3SC2_)	A217 C12 (3SC4_)
			Trim 2 (3SA82_)	Trim 12 (3SA8G_)					
1	Body	A216 WCB	A352 LCB		A217 WC1	A217 WC6	A217 WC9	A217 C5	A217 C12
2	Seat Ring	A105	A182 F304	A182 F316+HF	A182 F1+HF	A182 F11+HF	A182 F22+HF	A182 F5+HF	A182 F9+HF
3	Disc	A216 WCB	A351 CF8	A351 CF8M	A217 WC1+HF	A217 WC6+HF	A217 WC9+HF	A217 C5+HF	A217 C12+HF
4	Hinge	A216 WCB	A352 LCB		A217 WC1	A217 WC6	A217 WC9	A217 C5	A217 C12
5	Washer	SS304	SS304	SS316	SS304		SS304		
6	Disc Nut	A194 2H	A194 4		A194 4		A194 4		
7	Hinge Pin	A182 F6a	A182 F304	A182 F316	A182 F6a		A182 F6a		
8	Gasket	SS304 +Graphite	SS304 +Graphite	SS316 +Graphite	SS304 +Graphite		SS304 +Graphite		
9	Cover	A216 WCB	A352 LCB		A217 WC1	A217 WC6	A217 WC9	A217 C5	A217 C12
10	Cover Bolt	A193 B7	A320 L7		A193 B16		A193 B16		
11	Cover Nut	A194 2H	A194 4		A194 4		A194 4		
12	Eye Bolt	Carbon Steel	Carbon Steel		Carbon Steel		Carbon Steel		
13	Gasket	SS304	SS304	SS316	SS304		SS304		
14	Plug	A105	A350 LF2		A182 F1	A182 F11	A182 F22	A182 F5	A182 F9
15	Gland	A105	A350 LF2		A182 F1	A182 F11	A182 F22	A182 F5	A182 F9

Fig. 3SA0_	Seat Surface	Disc Surface
TRIM #1 (3SA01)	A105+13Cr	A216 WCB+13Cr
TRIM #5 (3SA05)	A105+HF	A216 WCB+HF
TRIM #8 (3SA08)	A105+HF	A216 WCB+13Cr

HF = Hard faced

Main Parts and Materials

SERIES 3S ANSI RANGE
Class 600

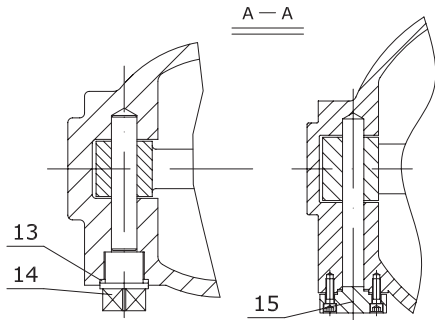
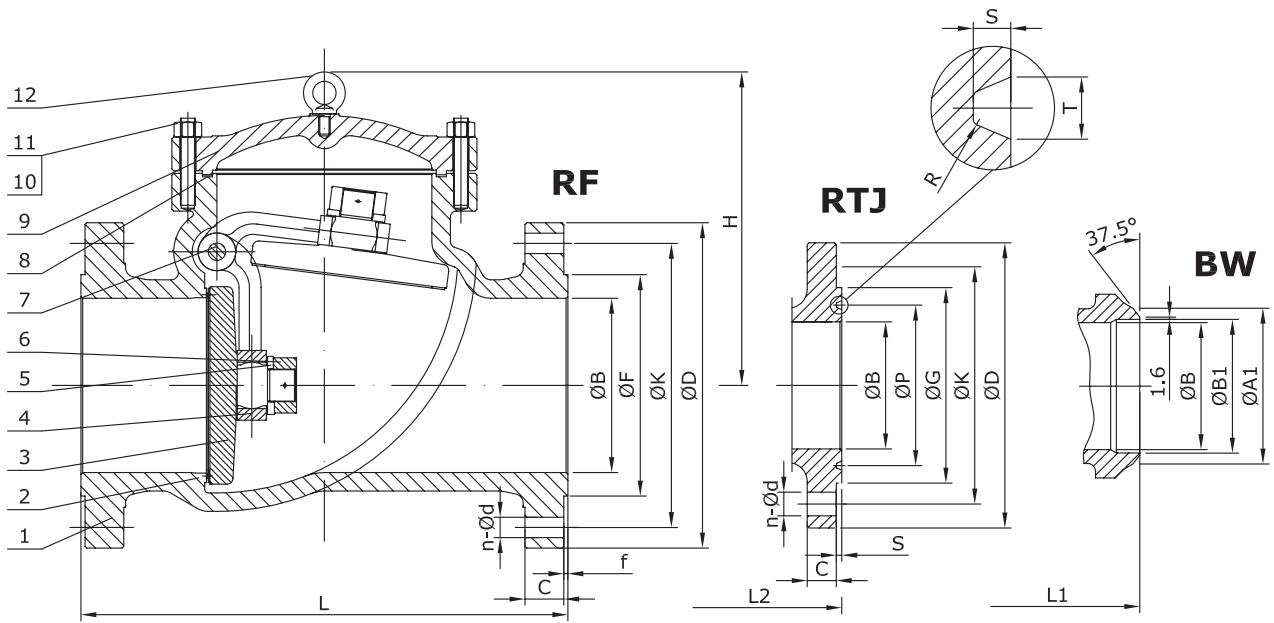

No.15 recommended:
Class600 - For size ≥ 12"

Gland/Prensa
NPS ≥ 16"

Nº	Part name	CF8 (3SI2_)	CF8M (3SI0_)	CF3 (3SI1_)	CF3M (3SI7_)
1	Body	A351 CF8	A351 CF8M	A351 CF3	A351 CF3M
2	Seat Ring	Integral SS304	Integral+HF	Integral SS304L	Integral+HF
3	Disc	A351 CF8	A351 CF8M	A351 CF3	A351 CF3M
4	Hinge	A351 CF8	A351 CF8M	A351 CF3	A351 CF3M
5	Washer	SS304	SS316	SS304L	SS316L
6	Disc Nut	A194 8	A194 8M	A194 8M	
7	Hinge Pin	A182 F304	A182 F316	A182 F304L	A182 F316L
8	Gasket	SS304+Graphite	SS316+Graphite	SS316+Graphite	SS316L+Graphite
9	Cover	A351 CF8	A351 CF8M	A351 CF3	A351 CF3M
10	Cover Bolt	A193 B8	A193 B8M	A193 B8M	
11	Cover Nut	A194 8	A194 8M	A194 8M	
12	Eye Bolt	Carbon Steel		Carbon Steel	
13	Gasket	SS304	SS316	SS304L	SS316L
14	Plug	A182 F304	A182 F316	A182 F304L	A182 F316L
15	Gland	A182 F304	A182 F316	A182 F304L	A182 F316L

Main Valve Parameters - Class 600

Nominal Size		inch	2"	2-1/2"	3"	4"	5"	6"	8"	10"
DN			50	65	80	100	125	150	200	250
End connection	RF	L	292	330	356	432	508	559	660	787
		ØB	51	65,375	76	102	128,25	152	200	248
		ØD	165	190	210	275	330	355	420	510
		ØK	127	149,2	168,3	215,9	266,7	292,1	349,2	431,8
		ØF	92,1	104,8	127	157,2	185,7	215,9	269,9	323,8
		C	25,4	28,6	31,8	38,1	44,5	47,7	55,6	63,5
		f	7	7	7	7	7	7	7	7
		n-Ød	8 - 3/4	8 - 7/8	8 - 7/8	8 - 1	8 - 1 1/8	12 - 1 1/8	12 - 1/4	16 - 1 3/8
	BW	L1	292	330	356	432	508	559	660	787
		Schedule No.(1)	80	-	80	80	-	80	80	80
		ØB	51	65,375	76	102	128,25	152	200	248
		ØA1	60,3	-	91	117	-	172	223	278
		ØB1	49,22	-	73,5	97	-	146,5	193,5	243
	RTJ	L2	295	346	372	448	524	562	663	790
		ØB	51	65,375	76	102	128,25	152	200	248
		ØD	165	190	210	275	330	355	420	510
		ØK	127	149,2	168,3	215,9	266,7	292,1	349,2	431,8
		ØG	108	127	146	175	210	241	302	356
		ØP	82,55	101,6	123,83	149,23	180,98	211,12	269,88	323,85
		C	25,4	28,6	31,8	38,1	44,5	47,7	55,6	63,5
		n-Ød	8 - 3/4	8 - 7/8	8 - 7/8	8 - 1	8 - 1 1/8	12 - 1 1/8	12 - 1/4	16 - 1 3/8
		T	11,91	11,91	11,91	11,91	11,91	11,91	11,91	11,91
		S	7,92	7,92	7,92	7,92	7,92	7,92	7,92	7,92
		R	0,8	0,8	0,8	0,8	0,8	0,8	0,8	0,8
	H		142	189	223	256	300	332	409	478
	Kvs-value		86	177	244	444	801	1064	1889	2906
	Approx. Weight RF (2)		22	34	43	78	122	155	285	485
Approx. Weight BW		15	24	30	55	87	111	221	382	

(1) Other schedule nos. on request
 (2) RTJ weight increases approx. by 10%

Dimensions in mm (except for bolt holes - Ød -, which are in inch units) subject to manufacturing tolerance
 Kvs-values in m³/h / Weights in kg
 For more information about flanged and welded ends refer to page 16

Main Valve Parameters - Class 600

SERIES 3S ANSI RANGE



Nominal Size		inch	12"	14"	16"	18"	20"	24"	26"	28"	
DN			300	350	400	450	500	600	650	700	
End connection	RF	L	838	889	991	1092	1194	1397	1448	1600	
		ØB	299	327	375	419	464	559	603	648	
		ØD	560	605	685	745	815	940	1015	1075	
		ØK	489	527	603,2	654	723,9	838,2	914,4	965,2	
		ØF	381	412,8	469,9	533,4	584,2	692,2	749	800	
		C	66,7	69,9	76,2	82,6	88,9	101,6	108	111,2	
		f	7	7	7	7	7	7	7	7	
		n-Ød	20 - 1 3/8	20 - 1 1/2	20 - 1 5/8	20 - 1 3/4	24 - 1 3/4	24 - 2	28 - 2	28 - 2 1/8	
	BW	L1	838	889	991	1092	1194	1397	1448	1600	
		Schedule No.(1)	80	80	80	80	80	80	-	-	
		ØB	299	327	375	419	464	559	603	648	
		ØA1	329	362	413	464	516	619	-	-	
		ØB1	289	317,5	363,5	409,5	455,5	547,5	-	-	
		L2	841	892	994	1095	1200	1407	1461	1613	
		ØB	299	327	375	419	464	559	603	648	
		ØD	560	605	685	745	815	940	1015	1075	
		ØK	489	527	603,2	654	723,9	838,2	914,4	965,2	
		RTJ	ØG	413	457	508	575	635	749	810	861
	ØP		981	419,1	469,9	533,4	584,2	692,15	749,3	800,1	
	C		66,7	69,9	76,2	82,6	88,9	101,6	108	111,2	
	n-Ød		20 - 1 3/8	20 - 1 1/2	20 - 1 5/8	20 - 1 3/4	24 - 1 3/4	24 - 2	28 - 2	28 - 2 1/8	
	T		11,91	11,91	11,91	11,91	13,49	16,66	19,84	19,84	
	S		7,92	7,92	7,92	7,92	9,53	11,13	12,7	12,7	
	R		0,8	0,8	0,8	0,8	1,5	1,5	1,5	1,5	
	H		539	609	660	769	890	954	1025	1062	
	Kvs-value		4376	5256	6897	8983	10987	15966	21026	25598	
	Approx. Weight RF (2)		615	920	1250	1800	2350	3300	3700	4500	
	Approx. Weight BW		493	740	1022	1512	1996	2862	3125	3854	

(1) Other schedule nos. on request
 (2) RTJ weight increases approx. by 10%

Dimensions in mm (except for bolt holes - Ød -, which are in inch units) subject to manufacturing tolerance
 Kvs-values in m³/h / Weights in kg
 For more information about flanged and welded ends refer to page 16

Main Parts and Materials

SERIES 3S ANSI RANGE
Class 900

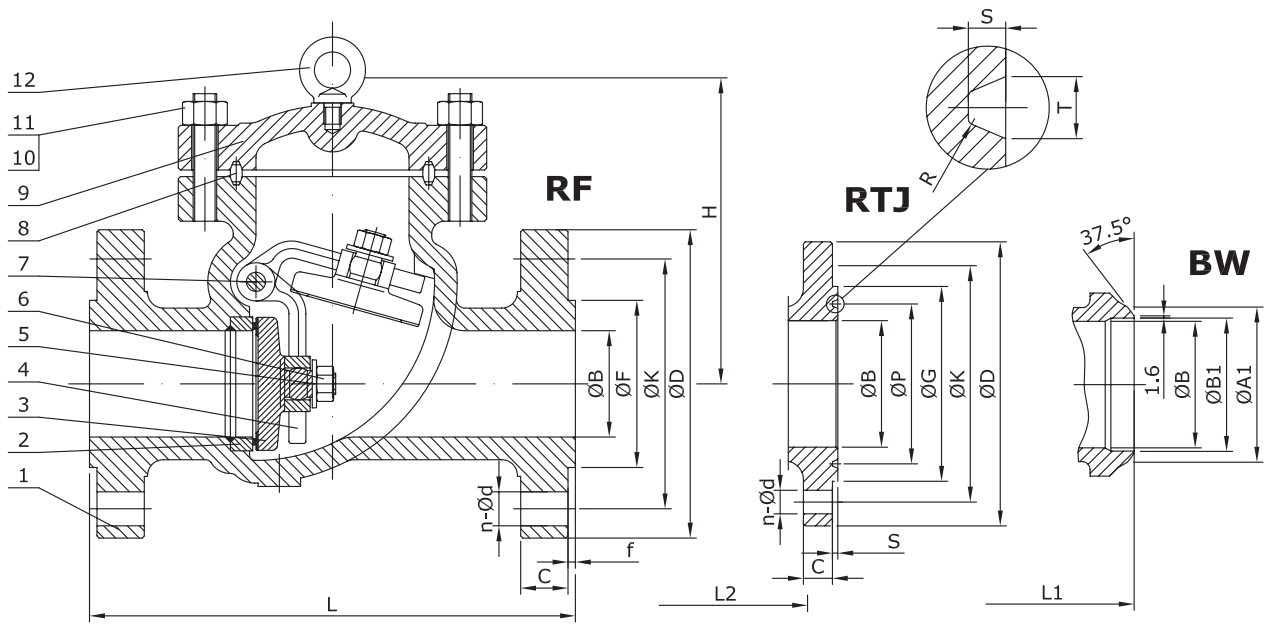

No.15 recommended:
Class900 - For size ≥ 6"

Gland/Prensa
NPS ≥ 16"

Nº	Part name	A216 WCB (3SA0_)	A352 LCB		A217 WC1 (3SB1_)	A217 WC6 (3SB8_)	A217 WC9 (3SB9_)	A217 C5 (3SC2_)	A217 C12 (3SC4_)
			Trim 15 (3SA8K_)	Trim 16 (3SA8L_)					
1	Body	A216 WCB	A352 LCB		A217 WC1	A217 WC6	A217 WC9	A217 C5	A217 C12
2	Seat Ring	A105	A182 F304+HF	A182 F316+HF	A182 F1+HF	A182 F11+HF	A182 F22+HF	A182 F5+HF	A182 F9+HF
3	Disc	A216 WCB	A351 CF8+HF	A351 CF8M+HF	A217 WC1+HF	A217 WC6+HF	A217 WC9+HF	A217 C5+HF	A217 C12+HF
4	Hinge	A216 WCB	A352 LCB		A217 WC1	A217 WC6	A217 WC9	A217 C5	A217 C12
5	Washer	SS304	SS304	SS316	SS304		SS304		
6	Disc Nut	A194 2H	A194 4		A194 4		A194 4		
7	Hinge Pin	A182 F6a	A182 F304	Nitronic 50	A182 F6a		A182 F6a		
8	Gasket	SS304	SS304	SS316	SS304		SS304		
9	Cover	A216 WCB	A352 LCB		A217 WC1	A217 WC6	A217 WC9	A217 C5	A217 C12
10	Cover Bolt	A193 B7	A320 L7		A193 B16		A193 B16		
11	Cover Nut	A194 2H	A194 4		A194 4		A194 4		
12	Eye Bolt	Carbon Steel	Carbon Steel		Carbon Steel		Carbon Steel		
13	Gasket	SS304	SS304	SS316	SS304		SS304		
14	Plug	A105	A350 LF2		A182 F1	A182 F11	A182 F22	A182 F5	A182 F9
15	Gland	A105	A350 LF2		A182 F1	A182 F11	A182 F22	A182 F5	A182 F9

Fig. 3SA0_	Seat Surface	Disc Surface
TRIM #1 (3SA01)	A105+13Cr	A216 WCB+13Cr
TRIM #5 (3SA05)	A105+HF	A216 WCB+HF
TRIM #8 (3SA08)	A105+HF	A216 WCB+13Cr

HF = Hard faced

Main Parts and Materials

SERIES 3S ANSI RANGE
Class 900

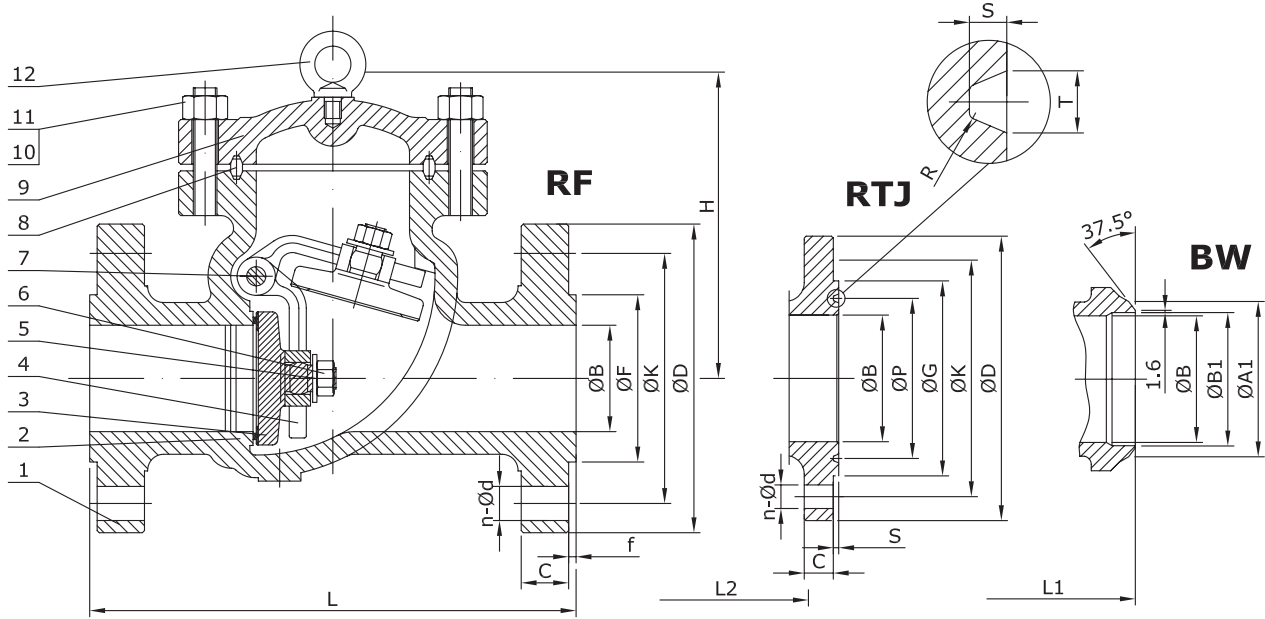

No.15 recommended:
Class900 - For size ≥ 6"

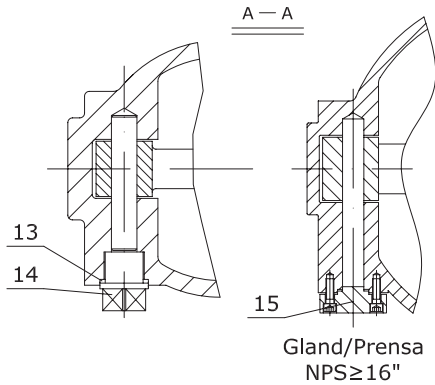

Nº	Part name	CF8 (3SI2_)	CF8M (3SI0_)	CF3 (3SI1_)	CF3M (3SI7_)
1	Body	A351 CF8	A351 CF8M	A351 CF3	A351 CF3M
2	Seat	Integral+HF	Integral+HF	Integral+HF	Integral+HF
3	Disc	A351 CF8+HF	A351 CF8M+HF	A351 CF3+HF	A351 CF3M+HF
4	Hinge	A351 CF8	A351 CF8M	A351 CF3	A351 CF3M
5	Washer	SS304	SS316	SS304L	SS316L
6	Disc Nut	A194 8	A194 8M	A194 8M	A194 8M
7	Hinge Pin	A182 F304	Nitronic 50	A182 F304L	Nitronic 50
8	Gasket	SS304	SS316	SS316	SS316L
9	Cover	A351 CF8	A351 CF8M	A351 CF3	A351 CF3M
10	Cover Bolt	A193 B8	A193 B8M	A193 B8M	A193 B8M
11	Cover Nut	A194 8	A194 8M	A194 8M	A194 8M
12	Eye Bolt	Carbon Steel	Carbon Steel	Carbon Steel	Carbon Steel
13	Gasket	SS304	SS316	SS304L	SS316L
14	Plug	A182 F304	A182 F316	A182 F304L	A182 F316L
15	Gland	A182 F304	A182 F316	A182 F304L	A182 F316L

Main Valve Parameters - Class 900

SERIES 3S ANSI RANGE



Nominal Size		inch	2"	2-1/2"	3"	4"	5"	6"	8"	
DN			50	65	80	100	125	150	200	
End connection	RF	L	368	419	381	457	559	610	737	
		ØB	48	62,375	73	98	123,2	146	191	
		ØD	215	245	240	290	350	380	470	
		ØK	165,1	190,5	190,5	235	279,4	317,5	393,7	
		ØF	92,1	104,8	127	157,2	185,7	215,9	269,9	
		C	38,1	41,3	38,1	44,5	50,8	55,6	63,5	
		f	7	7	7	7	7	7	7	
		n-Ød	8 - 7/8	8 - 1	8 - 7/8	8 - 1 1/8	8 - 1 1/4	12 - 1 1/8	12 - 1 3/8	
	BW	L1	368	419	381	457	559	610	737	
		Schedule No.(1)	160	-	160	120	-	120	100	
		ØB	48	62,375	73	98	123,2	146	191	
		ØA1	60,3	-	91	117	-	172	223	
		ØB1	38,16	-	66,5	92	-	140	189	
		L2	371	422	384	460	562	613	740	
		ØB	48	62,375	73	98	123,2	146	191	
		ØD	215	245	240	290	350	380	470	
		ØK	165,1	190,5	190,5	235	279,4	317,5	393,7	
		ØG	124	137	156	181	216	241	308	
		RTJ	ØP	95,25	107,95	123,83	149,23	180,98	211,12	269,88
			C	38,1	41,3	38,1	44,5	50,8	55,6	63,5
	n-Ød		8 - 7/8	8 - 1	8 - 7/8	8 - 1 1/8	8 - 1 1/4	12 - 1 1/8	12 - 1 3/8	
	T		11,91	11,91	11,91	11,91	11,91	11,91	11,91	
	S		7,92	7,92	7,92	7,92	7,92	7,92	7,92	
	R		0,8	0,8	0,8	0,8	0,8	0,8	0,8	
	H		175	220	254	314	353	381	533	
	Kvs-value		86	164	222	415	736	974	1718	
	Approx. Weight RF (2)	70	86	98	135	201	250	450		
	Approx. Weight BW	56	70	81	107	155	190	348		

(1) Other schedule nos. on request
 (2) RTJ weight increases approx. by 10%

Dimensions in mm (except for bolt holes - Ød -, which are in inch units) subject to manufacturing tolerance
 Kvs-values in m³/h / Weights in kg
 For more information about flanged and welded ends refer to page 16

Main Valve Parameters - Class 900

SERIES 3S ANSI RANGE



Nominal Size		inch	10"	12"	14"	16"	18"	20"	24"	
DN			250	300	350	400	450	500	600	
End connection	RF	L	838	965	1029	1130	1219	1321	1549	
		ØB	238	282	311	356	400	445	533	
		ØD	545	610	640	705	785	855	1040	
		ØK	469,9	533,4	558,8	616	685,8	749,3	901,7	
		ØF	323,8	381	412,8	469,9	533,4	584,2	692,2	
		C	69,9	79,4	85,8	88,9	101,6	108	139,7	
		f	7	7	7	7	7	7	7	
		n-Ød	16 - 1 3/8	20 - 1 3/8	20 - 1 1/2	20 - 1 5/8	20 - 1 7/8	20 - 2	20 - 2 1/2	
	BW	L1	838	965	1029	1130	1219	1321	1549	
		Schedule No.(1)	100	100	100	100	100	100	100	
		ØB	238	282	311	356	400	445	533	
		ØA1	278	329	362	413	464	516	619	
		ØB1	236,5	281	308	354	398,5	443	532	
		L2	841	968	1039	1140	1232	1334	1568	
		ØB	238	282	311	356	400	445	533	
		ØD	545	610	640	705	785	855	1040	
		ØK	469,9	533,4	558,8	616	685,8	749,3	901,7	
		RTJ	ØG	362	419	467	524	594	648	772
			ØP	323,85	381	419,1	469,9	533,4	584,2	692,15
			C	69,9	79,4	85,8	88,9	101,6	108	139,7
	n-Ød		16 - 1 3/8	20 - 1 3/8	20 - 1 1/2	20 - 1 5/8	20 - 1 7/8	20 - 2	20 - 2 1/2	
	T		11,91	11,91	16,66	16,66	19,84	19,84	26,97	
	S		7,92	7,92	11,13	11,13	12,7	12,7	15,88	
	R		0,8	0,8	1,5	1,5	1,5	1,5	2,4	
	H		558	609	736	762	863	939	1066	
	Kvs-value			2684	3923	4756	6214	8184	10103	14547
	Approx. Weight RF (2)			840	1180	1680	1980	2400	3200	5500
	Approx. Weight BW			698	984	1457	1711	2040	2752	4684

(1) Other schedule nos. on request
 (2) RTJ weight increases approx. by 10%

Dimensions in mm (except for bolt holes - Ød -, which are in inch units) subject to manufacturing tolerance
 Kvs-values in m³/h / Weights in kg
 For more information about flanged and welded ends refer to page 16

Main Parts and Materials

SERIES 31 ANSI RANGE
Class 1500&2500

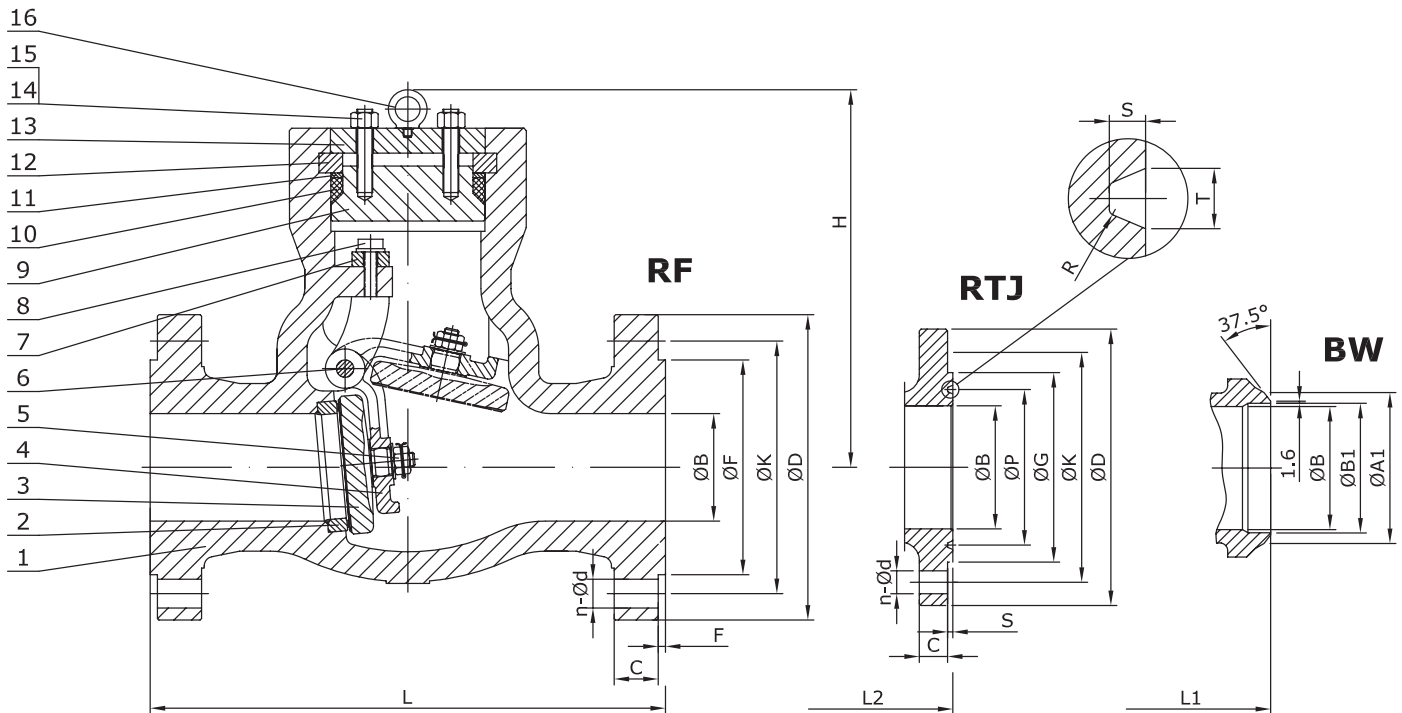

Nº	Part name	A216 WCB	A352 LCB		A217 WC1	A217 WC6	A217 WC9	A217 C5	A217 C12
		(31A0_)	Trim 15 (31A8K_)	Trim 16 (31A8L_)	(3SB1_)	(3SB8_)	(3SB9_)	(3SC2_)	(3SC4_)
1	Body	A216 WCB	A352 LCB		A217 WC1	A217 WC6	A217 WC9	A217 C5	A217 C12
2	Seat Ring	A105	A182 F304 +HF	A182 F316 +HF	A182 F1 +HF	A182 F11 +HF	A182 F22 +HF	A182 F5 +HF	A182 F9 +HF
3	Disc	A216 WCB	A351 CF8 +HF	A351 CF8M +HF	A217 WC1 +HF	A217 WC6 +HF	A217 WC9 +HF	A217 C5 +HF	A217 C12 +HF
4	Hinge	A216 WCB	A352 LCB		A217 WC1	A217 WC6	A217 WC9	A217 C5	A217 C12
5	Disc Nut	A194 2H	A194 4		A194 4		A194 4		A194 4
6	Hinge Pin	A182 F6a	A182 F304	Nitronic 50	A182 F6a		A182 F6a		A182 F6a
7	Gasket	SS304	SS304	SS316	SS304		SS304		SS304
8	Bolt	A193 B7	A320 L7		A193 B16		A193 B16		A193 B16
9	Cover	A105	A350 LF2		A182 F1	A182 F11	A182 F22	A182 F5	A182 F9
10	Gasket	SS304 +Graphite	SS304 +Graphite	SS316 +Graphite	SS304 +Graphite		SS304 +Graphite		SS304 +Graphite
11	Gasket Washer	A182 F6a	A182 F304	A182 F316	A182 F6a		A182 F6a		A182 F6a
12	Split Ring	A105	A350 LF2		A182 F1	A182 F11	A182 F22	A182 F5	A182 F9
13	Retainer Ring	A105	A350 LF2		A182 F1	A182 F11	A182 F22	A182 F5	A182 F9
14	Bolt	A193 B7	A320 L7		A193 B16		A193 B16		A193 B16
15	Nut	A194 2H	A194 4		A194 4		A194 4		A194 4
16	Eye Bolt	Carbon Steel	Carbon Steel		Carbon Steel		Carbon Steel		Carbon Steel

Fig. 31A0_	Seat Surface	Disc Surface
TRIM #1 (31A01)	A105+13Cr	A216 WCB+13Cr
TRIM #5 (31A05)	A105+HF	A216 WCB+HF
TRIM #8 (31A08)	A105+HF	A216 WCB+13Cr

HF = Hard faced

Main Parts and Materials

SERIES 31 ANSI RANGE
Class 1500&2500

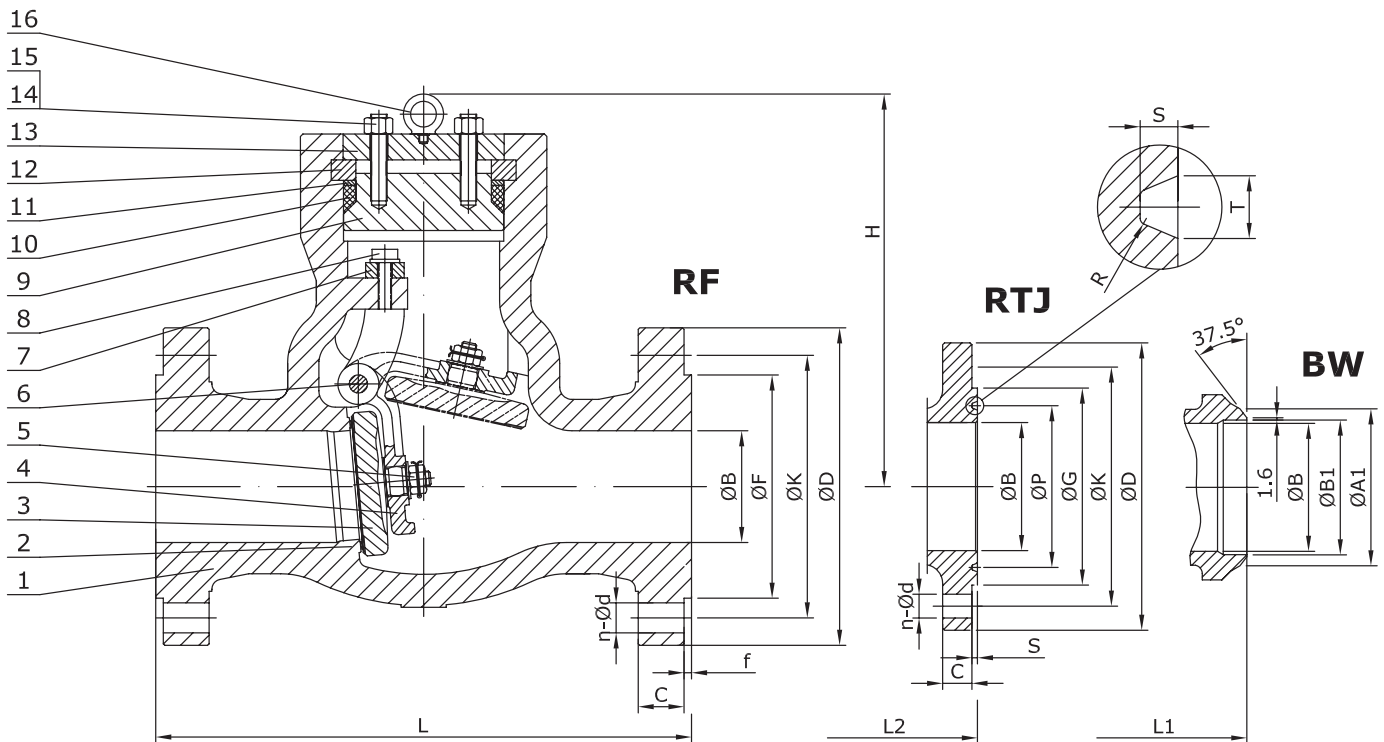

Nº	Part name	CF8 (3112_)	CF8M (3110_)	CF3 (3111_)	CF3M (3117_)
1	Body	A351 CF8	A351 CF8M	A351 CF3	A351 CF3M
2	Seat Ring	Integral+HF	Integral+HF	Integral+HF	Integral+HF
3	Disc	A351 CF8+HF	A351 CF8M+HF	A351 CF3+HF	A351 CF3M+HF
4	Hinge	A351 CF8	A351 CF8M	A351 CF3	A351 CF3M
5	Disc Nut	A194 8	A194 8M	A194 8M	A194 8M
6	Hinge Pin	A182 F304	Nitronic 50	A182 F304L	Nitronic 50
7	Gasket	SS304	SS316	SS304L	SS316L
8	Bolt	A193 B8	A193 B8M	A193 B8M	A193 B8M
9	Cover	A182 F304	A182 F316	A182 F304L	A182 F316L
10	Gasket	SS304+Graphite	SS316+Graphite	SS316+Graphite	SS316L+Graphite
11	Gasket Washer	A182 F304	A182 F316	A182 F304L	A182 F316L
12	Split Ring	A182 F304	A182 F316	A182 F304L	A182 F316L
13	Retainer Ring	A182 F304	A182 F316	A182 F304L	A182 F316L
14	Bolt	A193 B8	A193 B8M	A193 B8M	A193 B8M
15	Nut	A194 8	A194 8M	A194 8M	A194 8M
16	Eye Bolt	Carbon Steel	Carbon Steel	Carbon Steel	Carbon Steel

Main Valve Parameters - Class 1500

SERIES 31 ANSI RANGE

Nominal Size		inch	2"	2-1/2"	3"	4"	5"	6"	8"	10"	12"	14"	16"	
DN			50	65	80	100	125	150	200	250	300	350	400	
End connection	RF	L	368	419	470	546	673	705	832	991	1130	1257	1384	
		ØB	48	60,65	70	92	115,1	136	178	222	263	289	330	
		ØD	215	245	265	310	375	395	485	585	675	750	825	
		ØK	165,1	190,5	203,2	241,3	292,1	317,5	393,7	482,6	571,5	635	704,8	
		ØF	92,1	104,8	127	157,2	185,7	215,9	269,9	323,8	381	412,8	469,9	
		C	38,1	41,3	47,7	54	73,1	82,6	92,1	108	123,9	133,4	146,1	
		f	7	7	7	7	7	7	7	7	7	7	7	7
		n-Ød	8 - 7/8	8 - 1	8 - 1 1/4	8 - 1 3/8	8 - 1 5/8	12 - 1 1/2	12 - 1 3/4	12 - 2	16 - 2 1/8	16 - 2 3/8	16 - 2 5/8	
	BW	L1	368	419	470	546	673	705	832	991	1130	1257	1384	
		Schedule No.(1)	160	-	160	120	-	120	120	120	120	120	120	
		ØB	48	60,65	70	92	115,1	136	178	222	263	289	330	
		ØA1	60,3	-	91	117	-	172	223	278	329	362	413	
		ØB1	38,16	-	66,5	92	-	140	182,5	230	273	300	344,5	
		L2	371	422	473	549	676	711	842	1001	1146	1276	1406	
		ØB	48	60,65	70	92	115,1	136	178	222	263	289	330	
		ØD	215	245	265	310	375	395	485	585	675	750	825	
		ØK	165,1	190,5	203,2	241,3	292,1	317,5	393,7	482,6	571,5	635	704,8	
		ØG	124	137	168	194	229	248	318	371	438	489	546	
		ØP	95,25	107,95	136,53	161,93	193,68	211,14	269,88	323,85	381	419,1	469,9	
		C	38,1	41,3	47,7	54	73,1	82,6	92,1	108	123,9	133,4	146,1	
	RTJ	n-Ød	8 - 7/8	8 - 1	8 - 1 1/4	8 - 1 3/8	8 - 1 5/8	12 - 1 1/2	12 - 1 3/4	12 - 2	16 - 2 1/8	16 - 2 3/8	16 - 2 5/8	
		T	11,91	11,91	11,91	11,91	11,91	13,49	16,66	16,66	23,01	26,97	30,18	
		S	7,92	7,92	7,92	7,92	7,92	9,53	11,13	11,13	14,27	15,88	17,48	
		R	0,8	0,8	0,8	0,8	0,8	1,5	1,5	1,5	1,5	2,4	2,4	
		H	200	249	285	320	395	450	561	660	750	850	955	
		Kvs-value		65	146	205	363	646	855	1496	2338	3410	4103	5355
	Approx. Weight RF (2)		70	105	130	300	386	450	600	1190	1530	1854	2060	
	Approx. Weight BW		56	83	104	264	323	366	457	945	1166	1343	1380	

(1) Other schedule nos. on request
 (2) RTJ weight increases approx. by 10%

Dimensions in mm (except for bolt holes - Ød -, which are in inch units) subject to manufacturing tolerance
 Kvs-values in m³/h / Weights in kg
 For more information about flanged and welded ends refer to page 16

Main Valve Parameters - Class 2500

SERIES 31 ANSI RANGE



Nominal Size		inch	2"	2-1/2"	3"	4"	5"	6"	8"	10"	12"
DN			50	65	80	100	125	150	200	250	300
End connection	RF	L	451	508	578	673	794	914	1022	1270	1422
		ØB	38	48,925	57	73	92,95	111	146	184	219
		ØD	235	265	305	355	420	485	550	675	760
		ØK	171,4	196,8	228,6	273	323,8	368,3	438,2	539,8	619,1
		ØF	92,1	104,8	127	157,2	185,7	215,9	269,9	323,8	381
		C	50,9	57,2	66,7	76,2	92,1	108	127	165,1	184,2
		f	7	7	7	7	7	7	7	7	7
		n-Ød	8 - 1 1/8	8 - 1 1/4	8 - 1 3/8	8 - 1 5/8	8 - 1 7/8	8 - 2 1/8	12 - 2 1/8	12 - 2 5/8	12 - 2 7/8
	BW	L1	451	508	578	673	794	914	1022	1270	1422
		Schedule No.(1)	160	-	160	160	-	160	160	160	160
		ØB	38	48,925	57	73	92,95	111	146	184	219
		ØA1	60,3	-	91	117	-	172	223	278	329
		ØB1	42,82	-	66,5	87,5	-	132	173	216	257
		L2	454	511	581	676	797	918	1027	1276	1430
		ØB	38	48,925	57	73	92,95	111	146	184	219
		ØD	235	265	305	355	420	485	550	675	760
		ØK	171,4	196,8	228,6	273	323,8	368,3	438,2	539,8	619,1
		ØG	133	149	168	203	241	279	340	425	495
		ØP	101,6	111,13	127	157,18	190,5	228,6	279,4	342,9	406,4
		C	50,9	57,2	66,7	76,2	92,1	108	127	165,1	184,2
	RTJ	n-Ød	8 - 1 1/8	8 - 1 1/4	8 - 1 3/8	8 - 1 5/8	8 - 1 7/8	8 - 2 1/8	12 - 2 1/8	12 - 2 5/8	12 - 2 7/8
		T	11,91	13,49	13,49	16,66	19,84	19,84	23,01	30,18	33,32
		S	7,92	9,53	9,53	11,13	12,7	12,7	14,27	17,48	17,48
		R	0,8	1,5	1,5	1,5	1,5	1,5	1,5	2,4	2,4
		H	280	297	310	370	436	485	544	710	800
		Kvs-value	41	74	98	167	304	406	726	1154	1684
	Approx. Weight RF (2)	88	135	170	400	486	550	900	1600	2300	
	Approx. Weight BW	65	96	118	321	334	344	869	1018	1470	

(1) Other schedule nos. on request
 (2) RTJ weight increases approx. by 10%

Dimensions in mm (except for bolt holes - Ød -, which are in inch units) subject to manufacturing tolerance
 Kvs-values in m³/h / Weights in kg
 For more information about flanged and welded ends refer to page 16