

Disc check valve

Model 170

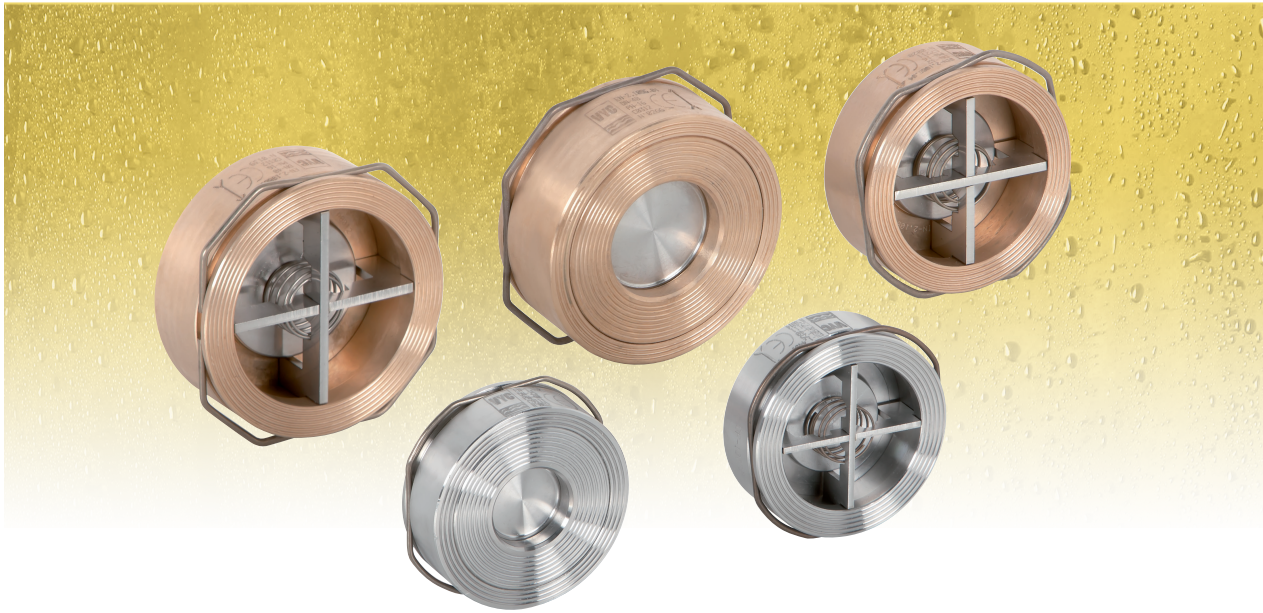

EN ASME/ANSI



Disc check valve with centering ring for placing between flanges in accordance with DIN, UNE, ANSI, BS, etc. norms. DN-15 to 100 (DN-125 to 200 see catalogue for Model 172).

For liquids, gases and steam.

For use in hydraulic, pneumatic, heating and steam systems, chemical and food industries, etc.

In accordance with the requirements of directive 2014/68/EU.

EC valve verification certified by: TÜV Rheinland Industrie Service GmbH, Notified Body for Pressure Equipment ID-No. 0035.

Final product verification EC examination (Module B) certified by: TÜV Rheinland Ibérica ICT, S.A.

Specifications

- Reduced assembly time in accordance with EN-558, basic series 49.
- Minimum load loss.
- Avoids ram shock when closing at zero pressure, remaining completely watertight at the time of fluid reversion.
- Highly tightness, exceeding the requirements of EN 12266-1.
- Easily assembled in any position in accordance with the direction of the fluid flow. Without spring only in vertical ascending direction.
- The valves have one single centering ring for placing between flanges according to DIN and UNE norms (PN-6, 10, 16, 25 and 40), ASA (ANSI) (PSI-150 and 300) and other norms (NF, BS, etc.), with the exception of the DN-100 valve with 3 centering rings duly marked with their corresponding flange norms to aid assembly.

IMPORTANT

Depending on demand:

- Possibility of manufacture in other types of material, for use in special working conditions (high temperatures, fluids, etc.).
- The fastener disc could be fitted up with PTFE joint (Teflón), Silicone's rubber, Fluorelastomer (Vitón), etc.

Nº. PIECE	PIECE	MATERIAL											
		BRONZE				CARBON STEEL				STAINLESS STEEL			
1	Body	Bronze (DIN-2.1086.04)				Carbon steel (EN-1.0580)				Stainless steel (EN-1.4401)			
2	Seating	Bronze (DIN-2.1086.04)				Stainless steel (EN-1.4028)				Stainless steel (EN-1.4401)			
3	Sealing disc	Stainless steel (EN-1.4401)				Stainless steel (EN-1.4401)				Stainless steel (EN-1.4401)			
4,5	Spring press	Stainless steel (EN-1.4401)				Stainless steel (EN-1.4401)				Stainless steel (EN-1.4401)			
6	Spring	Stainless steel (EN-1.4571)				Stainless steel (EN-1.4571)				Stainless steel (EN-1.4571)			
7	Centering ring	Stainless steel (EN-1.4310)				Stainless steel (EN-1.4310)				Stainless steel (EN-1.4310)			
DN		15 to 100											
PN		16				40				40			
OPERATING CONDITIONS	PRESSURE IN bar	16	15	14	13	40	35	28	21	40	34	32	29
	MAXIMUM TEMP. IN °C	120	180	200	250	120	200	300	400 ⁽¹⁾	120	200	300	400 ⁽¹⁾
	MINIMUM TEMP. IN °C	-60				-10				-60			

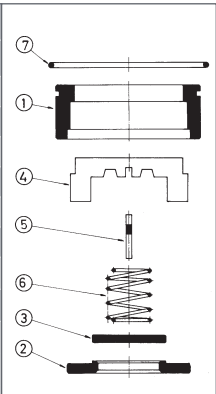

(1) For temperatures exceeding 300°C without spring only or depending on demand, with special spring.

DN		15	20	25	32	40	50	65	80	100		
		RING I	RING II	RING III								
H ₁		17	20	22	28	32	40	46	50	60	—	—
A ₁		44,5	54,5	64,5	75	84		117	133	153	—	—
D ₁		44,5	54,5	64,5	75	84	97,5	117	133	153	—	—
D ₂		52	65,5	72	83	93,5		127	154	168,5	192	178
D ₃		—	—	—	—	—	97,5	—	142,5	162,5	176	173
WEIGHT IN Kg.	BRONZE	0,14	0,24	0,35	0,56	0,82	1,10	2,15	2,90	4,02		
	CARBON STEEL	0,11	0,21	0,30	0,51	0,75	1,05	1,92	2,70	3,90		
	STAINLESS STEEL	0,11	0,21	0,30	0,51	0,75	1,05	1,92	2,70	3,90		
CODE	BRONZE	2003-170.5021	2003-170.5341	2003-170.5101	2003-170.5141	2003-170.5121	2003-170.5201	2003-170.5221	2003-170.5501	2003-170.5401		
	CARBON STEEL	2003-170.8024	2003-170.8344	2003-170.8104	2003-170.8144	2003-170.8124	2003-170.8204	2003-170.8224	2003-170.8504	2003-170.8404		
	STAINLESS STEEL	2003-170.8022	2003-170.8342	2003-170.8102	2003-170.8142	2003-170.8122	2003-170.8202	2003-170.8222	2003-170.8502	2003-170.8402		

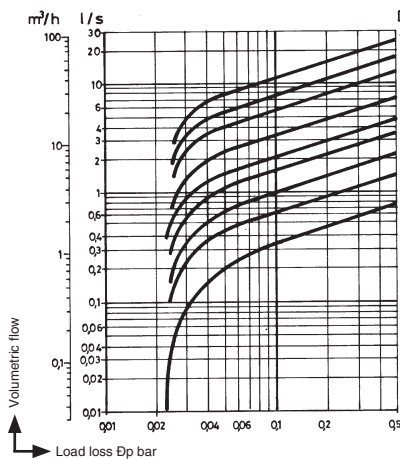
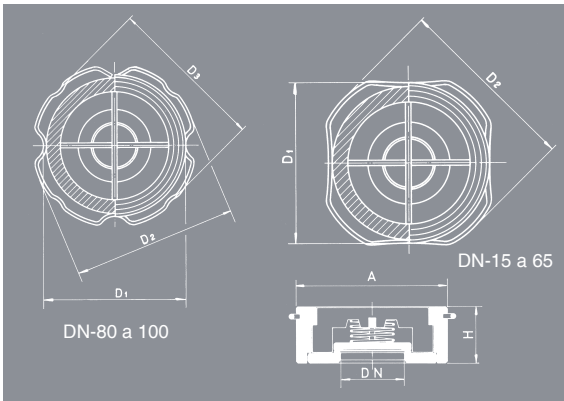

DIRECTION OF FLUID FLOW		OPENING PRESSURE IN mbar				FLOW COEFFICIENT	
		WITHOUT SPRING	WITH SPRING		Kv m³/h ΔP= 1 bar	Cv l/min ΔP= 1 Psi =0,07 bar	
			▲	▲			▶
DN	15	2,51	22,00	20,50	17,00	3,96	15,80
	20	2,38	21,90	20,50	17,10	7,20	32,50
	25	1,96	21,50	20,50	17,50	10,80	49,20
	32	3,70	23,20	20,50	15,80	18,00	80,00
	40	4,00	23,50	20,50	15,50	23,00	105,00
	50	4,11	23,60	20,50	15,40	36,00	166,00
	65	4,95	24,40	20,50	14,60	60,00	306,00
	80	5,64	25,10	20,50	13,90	79,00	382,00
	100	6,81	26,30	20,50	12,70	118,00	540,00

Load losses

The adjoining diagram reflects the load loss curves for water at 20°C. Values are based on valves without springs and installed horizontally. In the case of vertical flow, the variations are virtually unimportant.

In order to determine other fluids load losses, calculate the flow of these equivalent to water.

$$Q_A = \sqrt{\frac{\rho}{1.000}} \cdot Q$$

Q_A = Flow equivalent to water
In m³/h.

ρ = Fluid density in operating conditions in Kg/m³.

Q = Fluid flow in operating conditions in m³/h.