

**SERIES 90/91 ANSI RANGE**

Series 90 Gate Valves are linear motion valves devised for stopping the flow of the service fluid when necessary, not being suitable for regulating purpose. They are bolted bonnet, outside screw and yoke, rising stem, bidirectional, with metal sealing and full bore. The atmospheric sealing is achieved by flexible graphite rings. The two slightly sloped seats favor a tight shut off, being largely used in the power, chemical and oil industry sectors. The range is also comprehensive of a wide offer of different versions and options. The standard operation is achieved by handwheel or gear, depending on valve size and working pressure. Valves can also be arranged for automation with different kinds of actuators.

Precise machining of components for optimal performance

Outside screw and yoke, rising stem

Back Seat feature

Seat surface can be hardened to increase wear resistance

Flexible Wedge, favours the closure even at low pressures

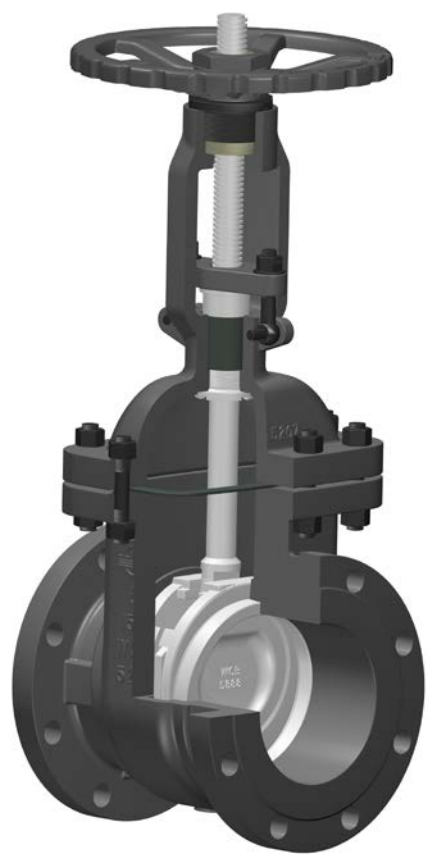

Ergonomic non-rising handwheel

Marking for identification and full traceability purpose

Great versatility in end connections, materials and configurations

Sloped valve seats, vertical shut off, flow assists closure

Full bore, minimum pressure drop

**Main Features / Reference Standards**

Design: API 600 or API 6D  
 Pressure Rating: 150/300/600/900/1500/2500#  
 Face to face length: ASME B16.10  
 Valve end connections: Flanged RF or RTJ to ASME B16.5 (size ≤ 24") / ASME B16.47 (size > 24")  
 Welded BW to ASME B16.25  
 Marking: MSS SP-25  
 Inspections & Tests: API 598  
 Bidirectional design  
 Primer painted grey color similar to RAL 7037 for protection during storage and transport (carbon steel body/bonnet)  
 Product compliant with Directive 2014/68/EU on Pressure Equipment (PED) and Machinery Directive 2006/42/EC for European Union territory

**Main Duties / Limits of use**

Fluids compatible with materials of construction. Questions referring to chemical resistance, please consult us  
 Pressure / Temperature Rating to ASME B16.34. See section "Engineering & Performance Data"  
 For products compliant with Directive 2014/68/EU, observe also limits acc. to Annex II tables 6 & 8 (gases & liquids group 1\*) and tables 7 & 9 (gases & liquids group 2\*) up to category III  
 \*Classification of fluids (group 1 or 2) acc. to Directive 2014/68/EU, Article 13

**Options**

Different body materials and trim combinations, different valve connections, extended bonnet, bellow seal, pressure seal, welded bonnet, lantern ring with double packing, live loaded packing, chained hand wheel, manual gear, pneumatic, electric or hydraulic actuation, limit switches, execution for aggressive atmosphere, etc. Please consult us

Main Parts and Materials

SERIES 90 ANSI RANGE  
Class 150

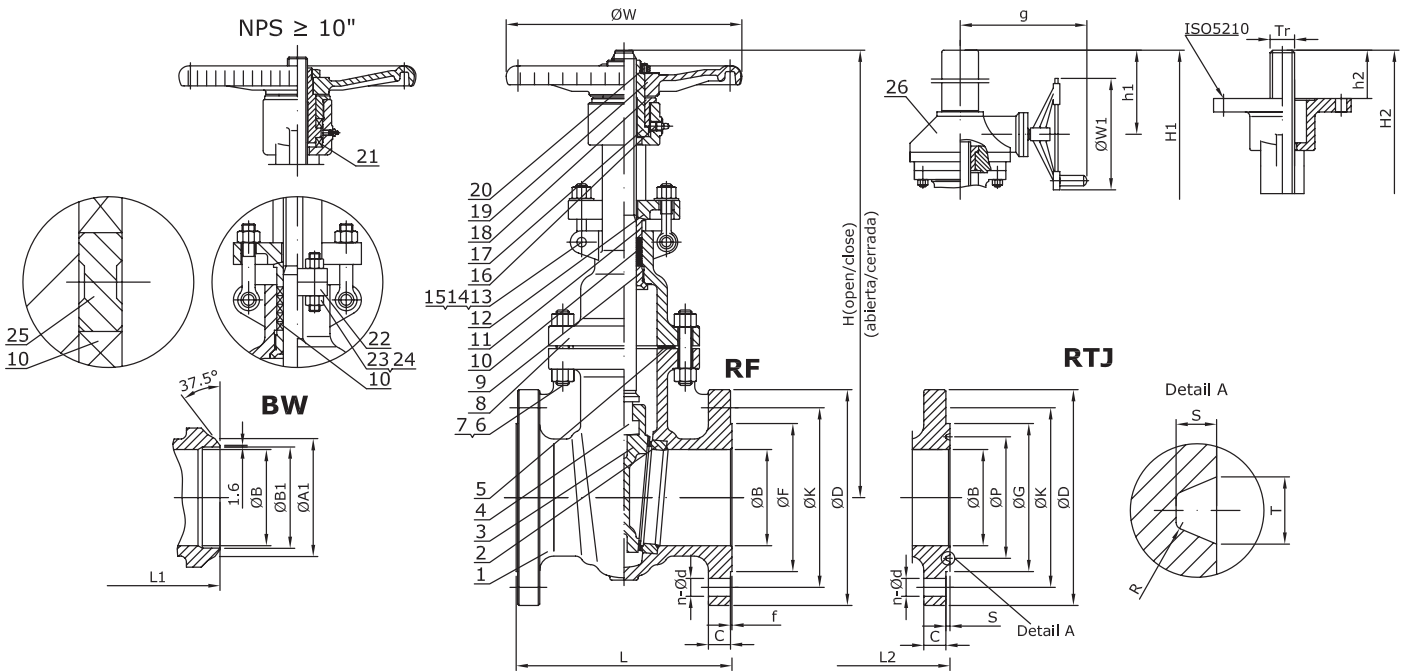

N°	Part name	A216 WCB (90A0_)	A352 LCB		A217 WC1 (90B1_)	A217 WC6 (90B8_)	A217 WC9 (90B9_)	A217 C5 (90C2_)	A217 C12 (90C4_)
			Trim 2 (90A82_)	Trim 12 (90A8G_)					
1	Body	A216 WCB	A352 LCB		A217 WC1	A217 WC6	A217 WC9	A217 C5	A217 C12
2	Seat Ring	A105	A182 F304	A182 F316+HF	A182 F1+HF	A182 F11+HF	A182 F22+HF	A182 F5+HF	A182 F9+HF
3	Wedge	A216 WCB	A351 CF8	A351 CF8M	A217 WC1+HF	A217 WC6+HF	A217 WC9+HF	A217 C5+HF	A217 C12+HF
4	Stem	A182 F6a	A182 F304	A182 F316	A182 F6a	A182 F6a	A182 F6a	A182 F6a	A182 F6a
5	Gasket	SS304 +Graphite	SS304 +Graphite		SS304 +Graphite		SS304+Graphite		
6	Bonnet Bolt	A193 B7	A320 L7		A193 B16		A193 B16		
7	Bonnet Nut	A194 2H	A194 4		A194 4		A194 4		
8	Bonnet	A216 WCB	A352 LCB		A217 WC1	A217 WC6	A217 WC9	A217 C5	A217 C12
9	Backseat Bushing	A182 F6a	A182 F304	A182 F316	A182 F6a		A182 F6a		
10	Packing	Graphite	Graphite		Graphite		Graphite		
11	Packing Gland	A182 F6a	A182 F304		A182 F6a		A182 F6a		
12	Gland Flange	A216 WCB	A352 LCB		A217 WC1	A217 WC6	A217 WC9	A217 C5	A217 C12
13	Eyebolt Pin	AISI 1025	AISI 1025		A276 410		A276 410		
14	Gland Eyebolt	A193 B7	A320 L7		A193 B16		A193 B16		
15	Gland Nut	A194 2H	A194 4		A194 4		A194 4		
16	Grease Nipple	Carbon Steel	Carbon Steel		Alloy Steel		Alloy Steel		
17	Stem Nut	A439 D2	A439 D2		A439 D2		A439 D2		
18	Retaining Nut	Carbon Steel	Carbon Steel		Carbon Steel		Carbon Steel		
19	Handwheel	Steel	Steel		Steel		Steel		
20	Handwheel Nut	Carbon Steel	Carbon Steel		Carbon Steel		Carbon Steel		
21	Bearings (1)	Alloy Steel	Alloy Steel		Alloy Steel		Alloy Steel		
22	Yoke (1)	A216 WCB	A352 LCB		A217 WC1	A217 WC6	A217 WC9	A217 C5	A217 C12
23	Yoke Bolt (1)	A193 B7	A320 L7		A193 B16		A193 B16		
24	Yoke Nut (1)	A194 2H	A194 4		A194 4		A194 4		
25	Lantern Ring (2)	A276 410	A276 304		A276 410		A276 410		
26	Gear	Assembly	Assembly		Assembly		Assembly		

(1) 10" and above; (2) On request

Fig. 90A0_	Seat Surface	Wedge Surface	Stem
TRIM #1 (90A01)	A105+13Cr	A216 WCB+13Cr	A182 F6a
TRIM #5 (90A05)	A105+HF	A216 WCB+HF	A182 F6a
TRIM #8 (90A08)	A105+HF	A216 WCB+13Cr	A182 F6a

HF = Hard faced

Information / restriction of technical rules need to be observed!  
Installation, Operating and Maintenance Manual can be downloaded at [www.comeval.es](http://www.comeval.es)

The engineer, designing a system or a plant, is responsible for the selection of the correct valve  
Product suitability must be verified, contact manufacturer for information

Main Parts and Materials

SERIES 90 ANSI RANGE  
Class 150

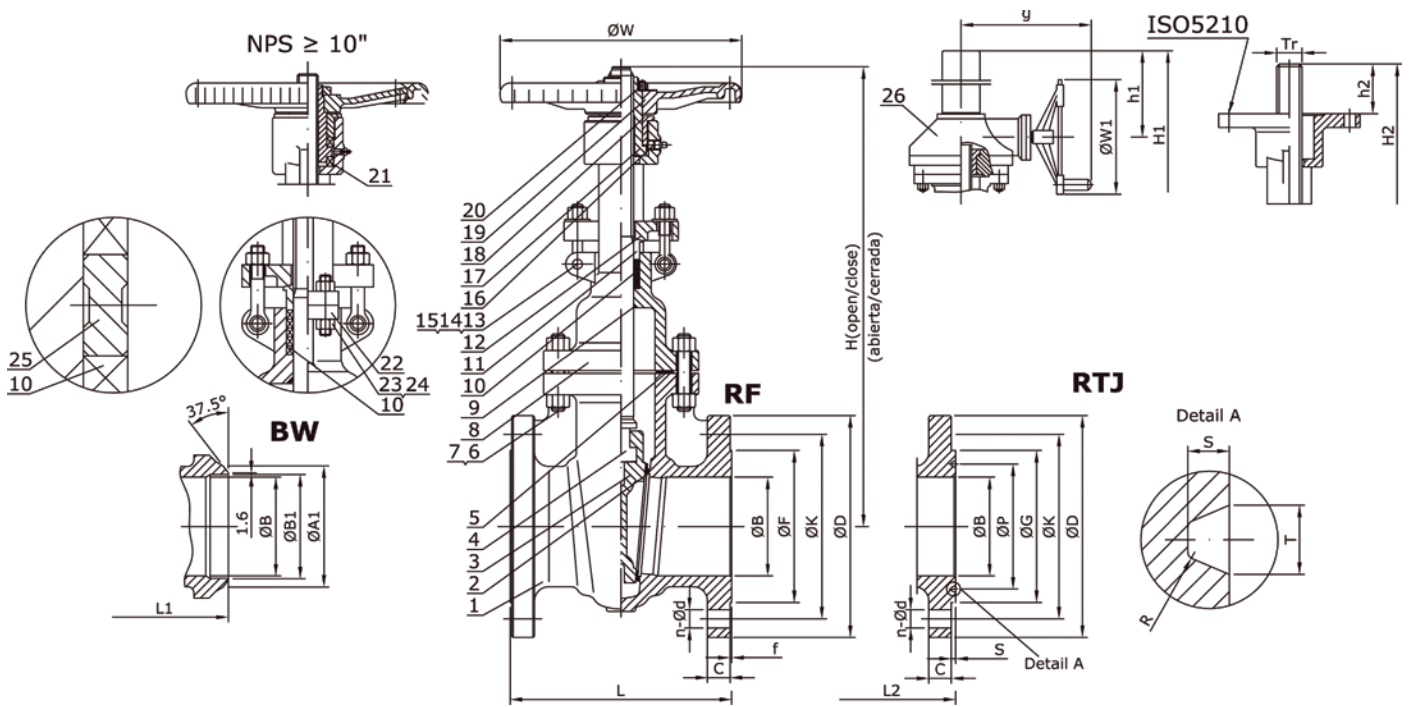

Nº	Part name	CF8 (9012_)	CF8M (9010_)	CF3 (9011_)	CF3M (9017_)
1	Body	A351 CF8	A351 CF8M	A351 CF3	A351 CF3M
2	Seat Ring	Integral SS304	Integral+HF	Integral SS304L	Integral SS316L
3	Wedge	A351 CF8	A351 CF8M	A351 CF3	A351 CF3M
4	Stem	A182 F304	A182 F316	A182 F304L	A182 F316L
5	Gasket	SS304+Graphite	SS316+Graphite	SS316+Graphite	SS316L+Graphite
6	Bonnet Bolt	A193 B8	A193 B8M	A193 B8M	
7	Bonnet Nut	A194 8	A194 8M	A194 8M	
8	Bonnet	A351 CF8	A351 CF8M	A351 CF3	A351 CF3M
9	Backseat Bushing	SS304	SS316	SS304L	SS316L
10	Packing	Graphite		Graphite	
11	Packing Gland	A182 F304	A182 F316	A182 F304L	A182 F316L
12	Gland Flange	A351 CF8	A351 CF8M	A351 CF3	A351 CF3M
13	Eyebolt Pin	A276 304	A276 316	A276 316	
14	Gland Eyebolt	A193 B8	A193 B8M	A193 B8M	
15	Gland Nut	A194 8	A194 8M	A194 8M	
16	Grease Nipple	St. Steel		St. Steel	
17	Stem Nut	A439 D2		A439 D2	
18	Retaining Nut	St. Steel		St. Steel	
19	Handwheel	Steel		Steel	
20	Handwheel Nut	St. Steel		St. Steel	
21	Bearings (1)	Alloy Steel		Alloy Steel	
22	Yoke (1)	A351 CF8	A351 CF8M	A351 CF3	A351 CF3M
23	Yoke Bolt (1)	A193 B8	A193 B8M	A193 B8M	
24	Yoke Nut (1)	A194 8	A194 8M	A194 8M	
25	Lantern Ring (2)	A276 304	A276 316	A276 316	A276 316L
26	Gear	Assembly		Assembly	

(1) 10" and above  
(2) On request

Main Valve Parameters - Class 150

SERIES 90 ANSI RANGE

Nominal Size		inch	2"	2-1/2"	3"	4"	5"	6"	8"	10"	12"	14"	16"	
DN			50	65	80	100	125	150	200	250	300	350	400	
End connection	RF	L	178	190	203	229	254	267	292	330	356	381	406	
		ØB	51	65,375	76	102	128,25	152	203	254	305	337	387	
		ØD	150	180	190	230	255	280	345	405	485	535	595	
		ØK	120,7	139,7	152,4	190,5	215,9	241,3	298,5	362	431,8	476,3	539,8	
		ØF	92,1	104,8	127	157,2	185,7	215,9	269,9	323,8	381	412,8	469,9	
		C	14,3	15,9	17,5	22,3	22,3	23,9	27	28,6	30,2	33,4	35	
		f	2	2	2	2	2	2	2	2	2	2	2	2
	n-Ød	4 - 3/4	4 - 3/4	4 - 3/4	8 - 3/4	8 - 7/8	8 - 7/8	8 - 7/8	8 - 7/8	12 - 1	12 - 1	12 - 1 1/8	16 - 1 1/8	
	BW	L1	216	241	282	305	381	403	419	457	502	572	610	
		Schedule No.(1)	40	-	40	40	-	40	40	40	STD	STD	STD	
		ØB	51	65,375	76	102	128,25	152	203	254	305	337	387	
		ØA1	60,3	-	91	117	-	172	223	278	329	362	413	
		ØB1	52,48	-	78	102	-	154	203	254,5	305	336,5	387,5	
	RTJ	L2	191	203	216	242	267	280	305	343	369	394	419	
		ØB	51	65,375	76	102	128,25	152	203	254	305	337	387	
		ØD	150	180	190	230	255	280	345	405	485	535	595	
		ØK	120,7	139,7	152,4	190,5	215,9	241,3	298,5	362	431,8	476,3	539,8	
		ØG	102	121	133	171	194	219	273	330	406	425	483	
		ØP	82,55	101,6	114,3	149,23	171,45	193,68	247,65	304,8	381	396,88	454,03	
		C	17,5	20,7	22,3	22,3	22,3	23,9	27	28,6	30,2	33,4	35	
		n-Ød	4 - 3/4	4 - 3/4	4 - 3/4	8 - 3/4	8 - 7/8	8 - 7/8	8 - 7/8	8 - 7/8	12 - 1	12 - 1	12 - 1 1/8	16 - 1 1/8
		T	8,74	8,74	8,74	8,74	8,74	8,74	8,74	8,74	8,74	8,74	8,74	8,74
		S	6,35	6,35	6,35	6,35	6,35	6,35	6,35	6,35	6,35	6,35	6,35	6,35
		R	0,8	0,8	0,8	0,8	0,8	0,8	0,8	0,8	0,8	0,8	0,8	0,8
	Top works/Operation	Hand-wheel	H (open)	396	452	493	595	684	766	952	1151	1376	1521	1735
			H (close)	336	376	406	473	543	595	738	879	1061	1167	1330
			ØW	200	250	250	280	300	300	350	400	450	500	550
		Gear with handwheel	H1	-	-	-	-	-	-	986	1205	1430	1585	1780
h1			-	-	-	-	-	-	245	320	370	415	465	
g			-	-	-	-	-	-	325	362	440	440	440	
ØW1			-	-	-	-	-	-	310	310	310	460	460	
With ISO 5210 mounting pad		H2 (open)	386	449	495	586	692	786	956	1155	1376	1525	1730	
		H2 (close)	326	373	408	473	555	615	742	883	1061	1171	1325	
		h2	45	54	60	60	72	80	80	80	80	100	100	
		ISO	F07	F10	F10	F10	F14	F14	F14	F14	F14	F14	F16	F16
		Tr	Tr20×4LH	Tr24×5LH	Tr24×5LH	Tr26×5LH	Tr30×6LH	Tr30×6LH	Tr32×6LH	Tr36×6LH	Tr38×6LH	Tr42×8LH	Tr46×8LH	
		Stroke	60	76	87	113	137	171	214	272	315	354	405	
		No. of turns	15	15	17	23	23	28,5	36	45	53	44	51	
Torque (Nm) (2)		36	42	47	85	102	115	202	267	350	480	686		
Kvs-value			171	422	607	1111	1996	2650	4889	7641	11410	13910	18427	
Approx. Weight RF (3)			15	22	27	43	59	70	105	163	249	358	450	
Approx. Weight BW			12	17	22	35	48	57	83	134	205	302	380	

(1) Other schedule nos. on request  
 (2) Torque includes 30% of safety factor  
 (3) RTJ weight increases approx. by 10%

Dimensions in mm (except for bolt holes - Ød -, which are in inch units) subject to manufacturing tolerance  
 Kvs-values in m³/h / Torques in Nm / Weights in kg  
 For more information about flanged and welded ends refer to page 16

Main Valve Parameters - Class 150

SERIES 90 ANSI RANGE



Nominal Size	inch	18"	20"	24"	26"	28"	30"	32"	36"	40"	42"	48"	
	DN	450	500	600	650	700	750	800	900	1000	1050	1200	
End connection	RF	L	432	457	508	559	610	610	610	711	812	812	1066
		ØB	438	489	591	633	684	735	779	874	976	1020	1166
		ØD	635	700	815	870	925	985	1060	1170	1290	1345	1510
		ØK	577,9	635	749,3	806,4	863,6	914,4	977,9	1085,8	1200,2	1257,3	1422,4
		ØF	533,4	584,2	692,2	749	800	857	914	1022	1124	1194	1359
		C	38,1	41,3	46,1	66,7	69,9	73,1	79,4	88,9	88,9	95,3	106,4
		f	2	2	2	2	2	2	2	2	2	2	2
		n-Ød	16 - 1 1/4	20 - 1 1/4	20 - 1 3/8	24 - 1 3/8	28 - 1 3/8	28 - 1 3/8	28 - 1 5/8	32 - 1 5/8	36 - 1 5/8	36 - 1 5/8	44 - 1 5/8
	BW	L1	660	711	813	864	914	914	965	1016	1066	1143	1371
		Schedule No.(1)	STD	STD	STD	20	20	20	20	20	XS	XS	XS
		ØB	438	489	591	633	684	735	779	874	976	1020	1166
		ØA1	464	516	619	670	721	772	825	927	1029	1079	1232
		ØB1	438	489	590,5	635	686	736,5	787,5	889	990,5	1041,5	1194
	RTJ	L2	445	470	521	-	-	-	-	-	-	-	-
		ØB	438	489	591	633	684	735	779	874	-	-	-
		ØD	635	700	815	870	925	985	1060	1170	-	-	-
		ØK	577,9	635	749,3	806,4	863,6	914,4	977,9	1085,8	-	-	-
		ØG	546	597	711	810	861	917	984	1092	-	-	-
		ØP	517,53	558,8	673,1	749,3	800,1	857,25	914,4	1022,35	-	-	-
		C	38,1	41,3	46,1	66,7	69,9	73,1	79,4	88,9	-	-	-
		n-Ød	16 - 1 1/4	20 - 1 1/4	20 - 1 3/8	24 - 1 3/8	28 - 1 3/8	28 - 1 3/8	28 - 1 5/8	32 - 1 5/8	-	-	-
		T	8,74	8,74	8,74	19,84	19,84	19,84	23,01	23,01	-	-	-
		S	6,35	6,35	6,35	12,7	12,7	12,7	14,27	14,27	-	-	-
		R	0,8	0,8	0,8	1,5	1,5	1,5	1,5	1,5	-	-	-
		Top works/Operation	Hand-wheel	H (open)	1944	-	-	-	-	-	-	-	-
	H (close)			1485	-	-	-	-	-	-	-	-	-
	ØW			600	-	-	-	-	-	-	-	-	-
	Gear with handwheel		H1	1984	2219	2595	2857	3019	3220	3380	3789	4254	4719
h1			516	592	693	775	837	890	952	1100	1248	1395	1565
g			440	513	513	513	513	588	588	588	588	613	613
ØW1			460	530	530	600	600	600	600	800	800	800	1000
With ISO 5210 mounting pad	H2 (open)		1949	2118	2509	2718	2922	3107	3368	3758	4151	4315	5719
	H2 (close)		1490	1607	1900	2073	2201	2332	2628	2930	3231	3360	4519
	h2		120	120	140	160	160	160	160	200	200	200	250
	ISO		F25	F25	F30	F35	F35	F35	F35	F40	F40	F48	F48
	Tr		Tr48x8LH	Tr52x8LH	Tr60x10LH	Tr62x8LH	Tr65x10LH	Tr65x10LH	Tr70x10LH	Tr76x10LH	Tr85x12LH	Tr90x12LH	Tr100x12LH
	Stroke		459	511	609	645	721	775	740	828	920	955	1200
	No. of turns		57	64	61	81	72	77,5	74	83	77	80	100
	Torque (Nm) (2)		903	1081	1910	2550	3560	3950	4320	4690	4850	5023	5675
Kvs-value			24547	30564	44585	54274	63932	73705	88034	110684	150308	190855	286752
Approx. Weight RF (3)			604	800	1168	1680	1900	2250	2400	3500	4120	5420	7200
Approx. Weight BW		527	708	1026	1508	1678	2011	2094	3060	2974	4130	5292	

(1) Other schedule nos. on request  
 (2) Torque includes 30% of safety factor  
 (3) RTJ weight increases approx. by 10%  
 (4) To be determined

Dimensions in mm (except for bolt holes - Ød -, which are in inch units) subject to manufacturing tolerance  
 Kvs-values in m³/h / Torques in Nm / Weights in kg  
 For more information about flanged and welded ends refer to page 16

Main Parts and Materials

SERIES 90 ANSI RANGE  
Class 300

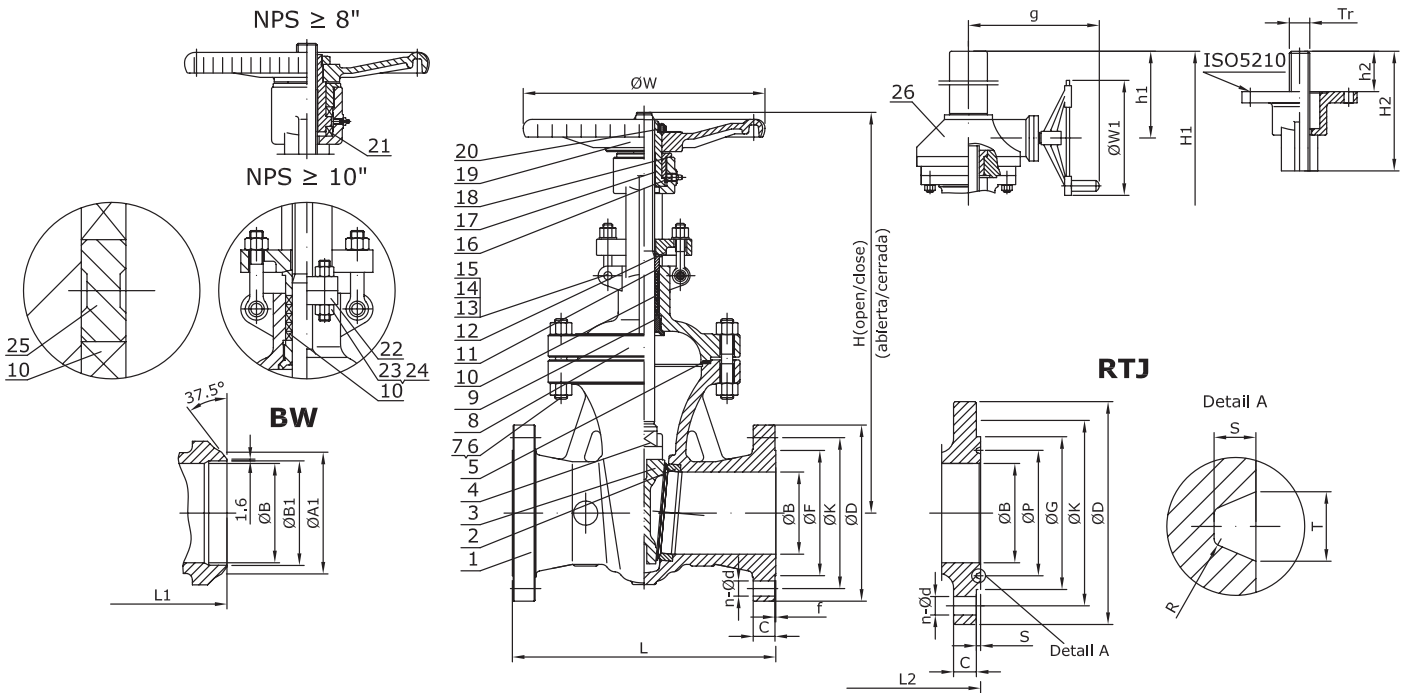

N°	Part name	A216 WCB (90A0_)	A352 LCB		A217 WC1 (90B1_)	A217 WC6 (90B8_)	A217 WC9 (90B9_)	A217 C5 (90C2_)	A217 C12 (90C4_)
			Trim 2 (90A82_)	Trim 12 (90A8G_)					
1	Body	A216 WCB	A352 LCB		A217 WC1	A217 WC6	A217 WC9	A217 C5	A217 C12
2	Seat Ring	A105	A182 F304	A182 F316+HF	A182 F1+HF	A182 F11+HF	A182 F22+HF	A182 F5+HF	A182 F9+HF
3	Wedge	A216 WCB	A351 CF8	A351 CF8M	A217 WC1+HF	A217 WC6+HF	A217 WC9+HF	A217 C5+HF	A217 C12+HF
4	Stem	A182 F6a	A182 F304	A182 F316	A182 F6a	A182 F6a	A182 F6a	A182 F6a	A182 F6a
5	Gasket	SS304 +Graphite	SS304 +Graphite		SS304 +Graphite		SS304+Graphite		
6	Bonnet Bolt	A193 B7	A320 L7		A193 B16		A193 B16		
7	Bonnet Nut	A194 2H	A194 4		A194 4		A194 4		
8	Bonnet	A216 WCB	A352 LCB		A217 WC1	A217 WC6	A217 WC9	A217 C5	A217 C12
9	Backseat Bushing	A182 F6a	A182 F304	A182 F316	A182 F6a		A182 F6a	A182 F6a	A182 F6a
10	Packing	Graphite	Graphite		Graphite		Graphite		
11	Packing Gland	A182 F6a	A182 F304		A182 F6a		A182 F6a		
12	Gland Flange	A216 WCB	A352 LCB		A217 WC1	A217 WC6	A217 WC9	A217 C5	A217 C12
13	Eyebolt Pin	AISI 1025	AISI 1025		A276 410		A276 410		
14	Gland Eyebolt	A193 B7	A320 L7		A193 B16		A193 B16		
15	Gland Nut	A194 2H	A194 4		A194 4		A194 4		
16	Grease Nipple	Carbon Steel	Carbon Steel		Alloy Steel		Alloy Steel		
17	Stem Nut	A439 D2	A439 D2		A439 D2		A439 D2		
18	Retaining Nut	Carbon Steel	Carbon Steel		Carbon Steel		Carbon Steel		
19	Handwheel	Steel	Steel		Steel		Steel		
20	Handwheel Nut	Carbon Steel	Carbon Steel		Carbon Steel		Carbon Steel		
21	Bearings (1)	Alloy Steel	Alloy Steel		Alloy Steel		Alloy Steel		
22	Yoke (2)	A216 WCB	A352 LCB		A217 WC1	A217 WC6	A217 WC9	A217 C5	A217 C12
23	Yoke Bolt (2)	A193 B7	A320 L7		A193 B16		A193 B16		
24	Yoke Nut (2)	A194 2H	A194 4		A194 4		A194 4		
25	Lantern Ring (3)	A276 410	A276 304		A276 410		A276 410		
26	Gear	Assembly	Assembly		Assembly		Assembly		

(1) 8" and above; (2) 10" and above; (3) On request

Fig. 90A0_	Seat Surface	Wedge Surface	Stem
TRIM #1 (90A01)	A105+13Cr	A216 WCB+13Cr	A182 F6a
TRIM #5 (90A05)	A105+HF	A216 WCB+HF	A182 F6a
TRIM #8 (90A08)	A105+HF	A216 WCB+13Cr	A182 F6a

HF = Hard faced

Information / restriction of technical rules need to be observed!  
Installation, Operating and Maintenance Manual can be downloaded at [www.comeval.es](http://www.comeval.es)

The engineer, designing a system or a plant, is responsible for the selection of the correct valve  
Product suitability must be verified, contact manufacturer for information

Main Parts and Materials

SERIES 90 ANSI RANGE  
Class 300

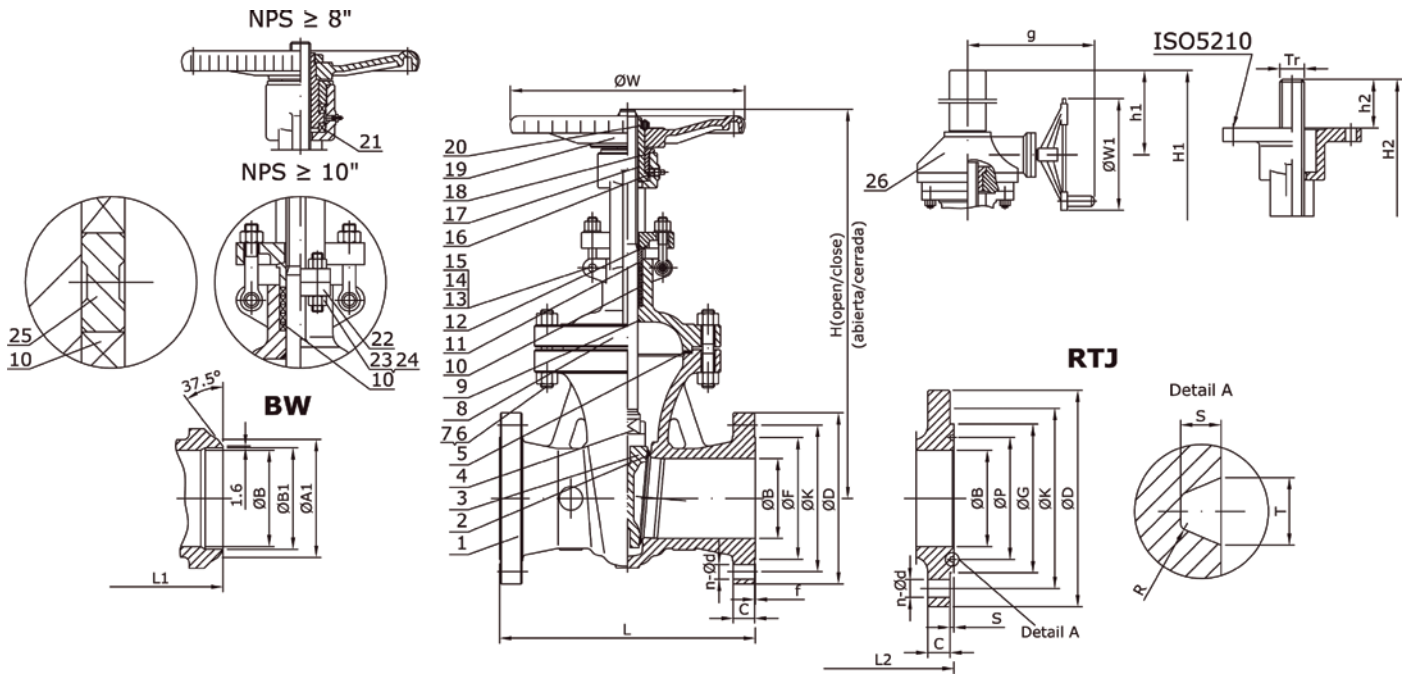

Nº	Part name	CF8 (90I2_)	CF8M (90I0_)	CF3 (90I1_)	CF3M (90I7_)
1	Body	A351 CF8	A351 CF8M	A351 CF3	A351 CF3M
2	Seat Ring	Integral SS304	Integral+HF	Integral SS304L	Integral SS316L
3	Wedge	A351 CF8	A351 CF8M	A351 CF3	A351 CF3M
4	Stem	A182 F304	A182 F316	A182 F304L	A182 F316L
5	Gasket	SS304+Graphite	SS316+Graphite	SS316+Graphite	SS316L+Graphite
6	Bonnet Bolt	A193 B8	A193 B8M	A193 B8M	
7	Bonnet Nut	A194 8	A194 8M	A194 8M	
8	Bonnet	A351 CF8	A351 CF8M	A351 CF3	A351 CF3M
9	Backseat Bushing	SS304	SS316	SS304L	SS316L
10	Packing	Graphite		Graphite	
11	Packing Gland	A182 F304	A182 F316	A182 F304L	A182 F316L
12	Gland Flange	A351 CF8	A351 CF8M	A351 CF3	A351 CF3M
13	Eyebolt Pin	A276 304	A276 316	A276 316	
14	Gland Eyebolt	A193 B8	A193 B8M	A193 B8M	
15	Gland Nut	A194 8	A194 8M	A194 8M	
16	Grease Nipple	St. Steel		St. Steel	
17	Stem Nut	A439 D2		A439 D2	
18	Retaining Nut	St. Steel		St. Steel	
19	Handwheel	Steel		Steel	
20	Handwheel Nut	St. Steel		St. Steel	
21	Bearings (1)	Alloy Steel		Alloy Steel	
22	Yoke (2)	A351 CF8	A351 CF8M	A351 CF3	A351 CF3M
23	Yoke Bolt (2)	A193 B8	A193 B8M	A193 B8M	
24	Yoke Nut (2)	A194 8	A194 8M	A194 8M	
25	Lantern Ring (3)	A276 304	A276 316	A276 316	A276 316L
26	Gear	Assembly		Assembly	

(1) 8" and above; (2) 10" and above; (3) On request

Main Valve Parameters - Class 300

SERIES 90 ANSI RANGE



Nominal Size	inch	2"	2-1/2"	3"	4"	5"	6"	8"	10"	12"	14"	16"		
	DN	50	65	80	100	125	150	200	250	300	350	400		
End connection	RF	L	216	241	282	305	-	403	419	457	502	762	838	
		ØB	51	65,375	76	102	128,25	152	203	254	305	337	387	
		ØD	165	190	210	255	280	320	380	445	520	585	650	
		ØK	127	149,2	168,3	200	235	269,9	330,2	387,4	450,8	514,4	571,5	
		ØF	92,1	104,8	127	157,2	185,7	215,9	269,9	323,8	381	412,8	469,9	
		C	20,7	23,9	27	30,2	33,4	35	39,7	46,1	49,3	52,4	55,6	
		f	2	2	2	2	2	2	2	2	2	2	2	2
	n-Ød	8 - 3/4	8 - 7/8	8 - 7/8	8 - 7/8	8 - 7/8	8 - 7/8	12 - 7/8	12 - 1	16 - 1 1/8	16 - 1 1/4	20 - 1 1/4	20 - 1 3/8	
	BW	L1	216	241	282	305	-	403	419	457	502	762	838	
		Schedule No.(1)	40	-	40	40	-	40	40	40	STD	STD	STD	
		ØB	51	65,375	76	102	128,25	152	203	254	305	337	387	
		ØA1	60,3	-	91	117	-	172	223	278	329	362	413	
		ØB1	52,48	-	78	102	-	154	203	254,5	305	336,5	387,5	
	RTJ	L2	232	257	298	321	-	419	435	473	518	778	854	
		ØB	51	65,375	76	102	128,25	152	203	254	305	337	387	
		ØD	165	190	210	255	280	320	380	445	520	585	650	
		ØK	127	149,2	168,3	200	235	269,9	330,2	387,4	450,8	514,4	571,5	
		ØG	108	127	146	175	210	241	302	356	413	457	508	
		ØP	82,55	101,6	123,83	149,23	180,98	211,12	269,88	323,85	981	419,1	469,9	
		C	20,7	23,9	27	30,2	33,4	35	39,7	46,1	49,3	52,4	55,6	
		n-Ød	8 - 3/4	8 - 7/8	8 - 7/8	8 - 7/8	8 - 7/8	8 - 7/8	12 - 7/8	12 - 1	16 - 1 1/8	16 - 1 1/4	20 - 1 1/4	20 - 1 3/8
		T	11,91	11,91	11,91	11,91	11,91	11,91	11,91	11,91	11,91	11,91	11,91	11,91
		S	7,92	7,92	7,92	7,92	7,92	7,92	7,92	7,92	7,92	7,92	7,92	7,92
		R	0,8	0,8	0,8	0,8	0,8	0,8	0,8	0,8	0,8	0,8	0,8	0,8
	Top works/Operation	Hand-wheel	H (open)	419	480	525	618	720	796	1033	1230	1403	1607	1865
			H (close)	359	408	445	503	581	639	817	963	1085	1245	1460
			ØW	200	229	250	280	320	350	400	450	500	550	600
		Gear with handwheel	H1	-	-	-	-	-	-	1091	1274	1459	1644	1806
h1			-	-	-	-	-	-	270	320	378	415	464	
g			-	-	-	-	-	-	362	440	440	440	440	
ØW1			-	-	-	-	-	-	310	310	460	460	460	
With ISO 5210 mounting pad		H2 (open)	426	488	533	633	729	800	1033	1237	1423	1627	1885	
		H2 (close)	366	416	453	518	590	643	817	970	1105	1265	1480	
		h2	60	60	60	80	80	80	80	100	120	140	140	
		ISO	F10	F10	F10	F14	F14	F14	F14	F16	F25	F30	F30	
		Tr	Tr20x4LH	Tr24x5LH	Tr24x5LH	Tr26x5LH	Tr32x6LH	Tr32x6LH	Tr36x6LH	Tr38x6LH	Tr42x8LH	Tr46x8LH	Tr48x8LH	
		Stroke	60	72	80	115	139	157	216	267	318	362	405	
		No. of turns	15	14	16	23	23	26	36	45	40	45	51	
Torque (Nm) (2)		52	61	68	134	196	241	394	681	918	1340	1703		
Kvs-value		171	422	607	1111	1996	2650	4889	7641	11410	13910	18427		
Approx. Weight RF (3)		23	35	43	67	96	118	194	300	418	671	900		
Approx. Weight BW		18	28	35	54	78	95	158	251	344	570	767		

(1) Other schedule nos. on request  
 (2) Torque includes 30% of safety factor  
 (3) RTJ weight increases approx. by 10%

Dimensions in mm (except for bolt holes - Ød -, which are in inch units) subject to manufacturing tolerance  
 Kvs-values in m³/h / Torques in Nm / Weights in kg  
 For more information about flanged and welded ends refer to page 16



Main Valve Parameters - Class 300

SERIES 90 ANSI RANGE

Nominal Size		inch	18"	20"	24"	26"	28"	30"	32"	36"	40"	42"	
DN			450	500	600	650	700	750	800	900	1000	1050	
End connection	RF	L	914	991	1143	1245	1346	1397	1524	1727	1955	2032	
		ØB	432	483	584	633	684	735	779	874	976	1020	
		ØD	710	775	915	970	1035	1090	1150	1270	1240	1290	
		ØK	628,6	685,8	812,8	876,3	939,8	997	1054,1	1168,4	1155,7	1206,5	
		ØF	533,4	584,2	692,2	749	800	857	914	1022	1086	1137	
		C	58,8	62	68,3	77,8	84,2	90,5	96,9	103,2	112,8	117,5	
		f	2	2	2	2	2	2	2	2	2	2	
		n-Ød	24 - 1 3/8	24 - 1 3/8	24 - 1 5/8	28 - 1 3/4	28 - 1 3/4	28 - 1 7/8	28 - 2	32 - 2 1/8	32 - 1 3/4	32 - 1 3/4	
	BW	L1	914	991	1143	1245	1346	1397	1524	1727	1955	2032	
		Schedule No.(1)	STD	STD	STD	20	20	20	20	20	XS	XS	
		ØB	432	483	584	633	684	735	779	874	976	1020	
		ØA1	464	516	619	670	721	772	825	927	1029	1079	
		ØB1	438	489	590,5	635	686	736,5	787,5	889	990,5	1041,5	
	RTJ	L2	930	1010	1165	1273	1371	1422	1552	1755	-	-	
		ØB	432	483	584	633	684	735	779	874	-	-	
		ØD	710	775	915	970	1035	1090	1150	1270	-	-	
		ØK	628,6	685,8	812,8	876,3	939,8	997	1054,1	1168,4	-	-	
		ØG	575	635	749	810	861	917	984	1092	-	-	
		ØP	533,4	584,2	692,15	749,3	800,1	857,25	914,4	1022,35	-	-	
		C	58,8	62	68,3	77,8	84,2	90,5	96,9	103,2	-	-	
		n-Ød	24 - 1 3/8	24 - 1 3/8	24 - 1 5/8	28 - 1 3/4	28 - 1 3/4	28 - 1 7/8	28 - 2	32 - 2 1/8	-	-	
		T	11,91	13,49	16,66	19,84	19,84	19,84	23,01	23,01	-	-	
		S	7,92	9,53	11,13	12,7	12,7	12,7	14,27	14,27	-	-	
	R	0,8	1,5	1,5	1,5	1,5	1,5	1,5	1,5	-	-		
	Top works/Operation	Hand-wheel	H (open)	1964	-	-	-	-	-	-	-	-	-
			H (close)	1516	-	-	-	-	-	-	-	-	-
			ØW	600	-	-	-	-	-	-	-	-	-
		Gear with handwheel	H1	1941	2430	2605	2880	3124	3279	3484	3888	4417	4640
h1			535	603	730	865	1015	1175	1353	1576	1829	2136	
g			513	513	513	588	588	588	588	613	613	613	
ØW1			530	530	600	600	600	600	600	800	800	1000	
With ISO 5210 mounting pad		H2 (open)	1981	2490	2673	2808	2958	3123	3289	3615	-	-	
		H2 (close)	1533	1990	2055	2158	2260	2372	2490	2715	-	-	
		h2	140	160	160	200	200	200	250	250	-	-	
		ISO	F30	F35	F35	F40	F40	F40	F48	F48	-	-	
		Tr	Tr52×8LH	Tr55×8LH	Tr65×10LH	Tr70×10LH	Tr76×10LH	Tr85×10LH	Tr90×12LH	Tr100×12LH	-	-	
		Stroke	448	500	618	650	698	751	799	900	-	-	
		No. of turns	56	63	62	65	70	75	67	75	-	-	
Torque (Nm) (2)		2059	2900	3500	4012	4500	4923	5230	5785	-	-		
Kvs-value			24607	29778	43632	53001	62432	72449	85966	107543	146786	185470	
Approx. Weight RF (3)			1194	1670	2300	2800	3200	4050	5200	7500	9000	9750	
Approx. Weight BW			1028	1465	2004	2454	2792	3563	4638	6773	8521	9217	

(1) Other schedule nos. on request  
 (2) Torque includes 30% of safety factor  
 (3) RTJ weight increases approx. by 10%

Dimensions in mm (except for bolt holes - Ød -, which are in inch units) subject to manufacturing tolerance  
 Kvs-values in m³/h / Torques in Nm / Weights in kg  
 For more information about flanged and welded ends refer to page 16

Main Parts and Materials

SERIES 90 ANSI RANGE  
Class 600

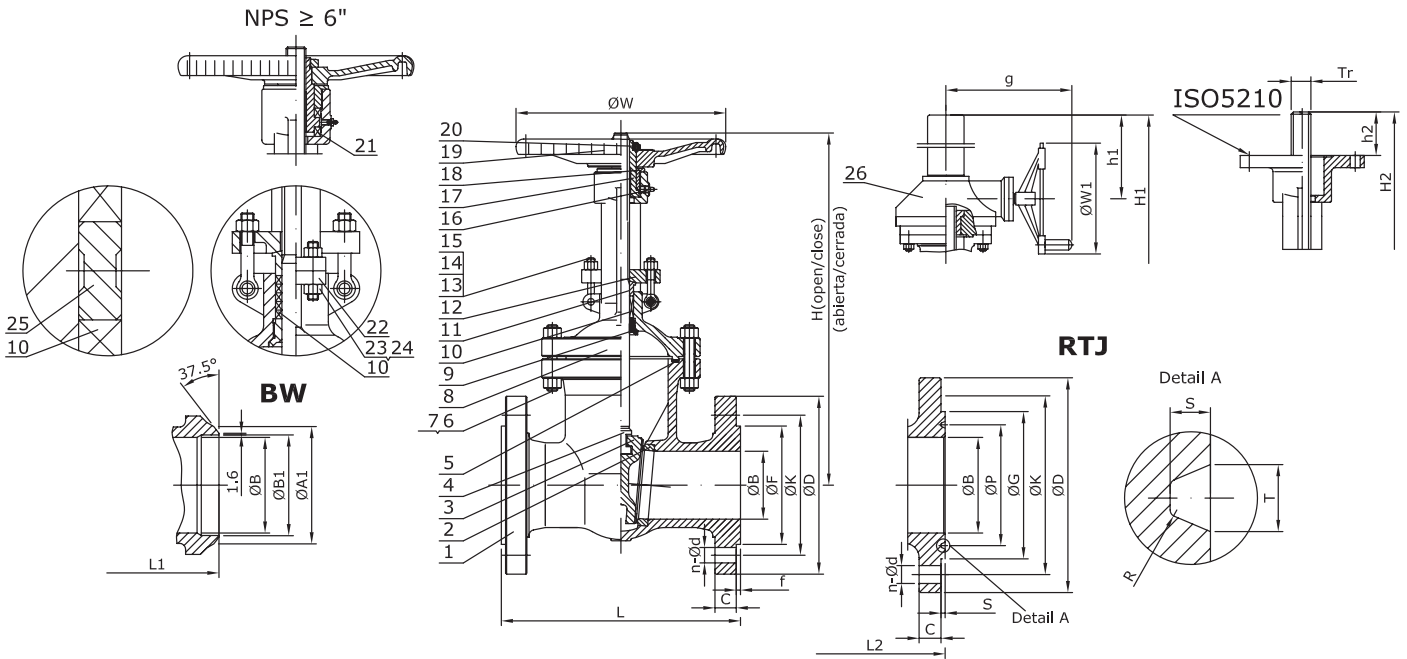

N°	Part name	A216 WCB (90A0_)	A352 LCB		A217 WC1 (90B1_)	A217 WC6 (90B8_)	A217 WC9 (90B9_)	A217 C5 (90C2_)	A217 C12 (90C4_)
			Trim 2 (90A82_)	Trim 12 (90A8G_)					
1	Body	A216 WCB	A352 LCB		A217 WC1	A217 WC6	A217 WC9	A217 C5	A217 C12
2	Seat Ring	A105	A182 F304	A182 F316+HF	A182 F1+HF	A182 F11+HF	A182 F22+HF	A182 F5+HF	A182 F9+HF
3	Wedge	A216 WCB	A351 CF8	A351 CF8M	A217 WC1+HF	A217 WC6+HF	A217 WC9+HF	A217 C5+HF	A217 C12+HF
4	Stem	A182 F6a	A182 F304	A182 F316	A182 F6a	A182 F6a	A182 F6a	A182 F6a	A182 F6a
5	Gasket	SS304 +Graphite	SS304 +Graphite		SS304 +Graphite		SS304+Graphite		
6	Bonnet Bolt	A193 B7	A320 L7		A193 B16		A193 B16		
7	Bonnet Nut	A194 2H	A194 4		A194 4		A194 4		
8	Bonnet	A216 WCB	A352 LCB		A217 WC1	A217 WC6	A217 WC9	A217 C5	A217 C12
9	Backseat Bushing	A182 F6a	A182 F304	A182 F316	A182 F6a		A182 F6a	A182 F6a	A182 F6a
10	Packing	Graphite	Graphite		Graphite		Graphite		
11	Packing Gland	A182 F6a	A182 F304		A182 F6a		A182 F6a		
12	Gland Flange	A216 WCB	A352 LCB		A217 WC1	A217 WC6	A217 WC9	A217 C5	A217 C12
13	Eyebolt Pin	AISI 1025	AISI 1025		A276 410		A276 410		
14	Gland Eyebolt	A193 B7	A320 L7		A193 B16		A193 B16		
15	Gland Nut	A194 2H	A194 4		A194 4		A194 4		
16	Grease Nipple	Carbon Steel	Carbon Steel		Alloy Steel		Alloy Steel		
17	Stem Nut	A439 D2	A439 D2		A439 D2		A439 D2		
18	Retaining Nut	Carbon Steel	Carbon Steel		Carbon Steel		Carbon Steel		
19	Handwheel	Steel	Steel		Steel		Steel		
20	Handwheel Nut	Carbon Steel	Carbon Steel		Carbon Steel		Carbon Steel		
21	Bearings (1)	Alloy Steel	Alloy Steel		Alloy Steel		Alloy Steel		
22	Yoke (1)	A216 WCB	A352 LCB		A217 WC1	A217 WC6	A217 WC9	A217 C5	A217 C12
23	Yoke Bolt (1)	A193 B7	A320 L7		A193 B16		A193 B16		
24	Yoke Nut (1)	A194 2H	A194 4		A194 4		A194 4		
25	Lantern Ring (2)	A276 410	A276 304		A276 410		A276 410		
26	Gear	Assembly	Assembly		Assembly		Assembly		

(1) 6" and above; (2) On request

Fig. 90A0_	Seat Surface	Wedge Surface	Stem
TRIM #1 (90A01)	A105+13Cr	A216 WCB+13Cr	A182 F6a
TRIM #5 (90A05)	A105+HF	A216 WCB+HF	A182 F6a
TRIM #8 (90A08)	A105+HF	A216 WCB+13Cr	A182 F6a

HF = Hard faced

Main Parts and Materials

SERIES 90 ANSI RANGE  
Class 600

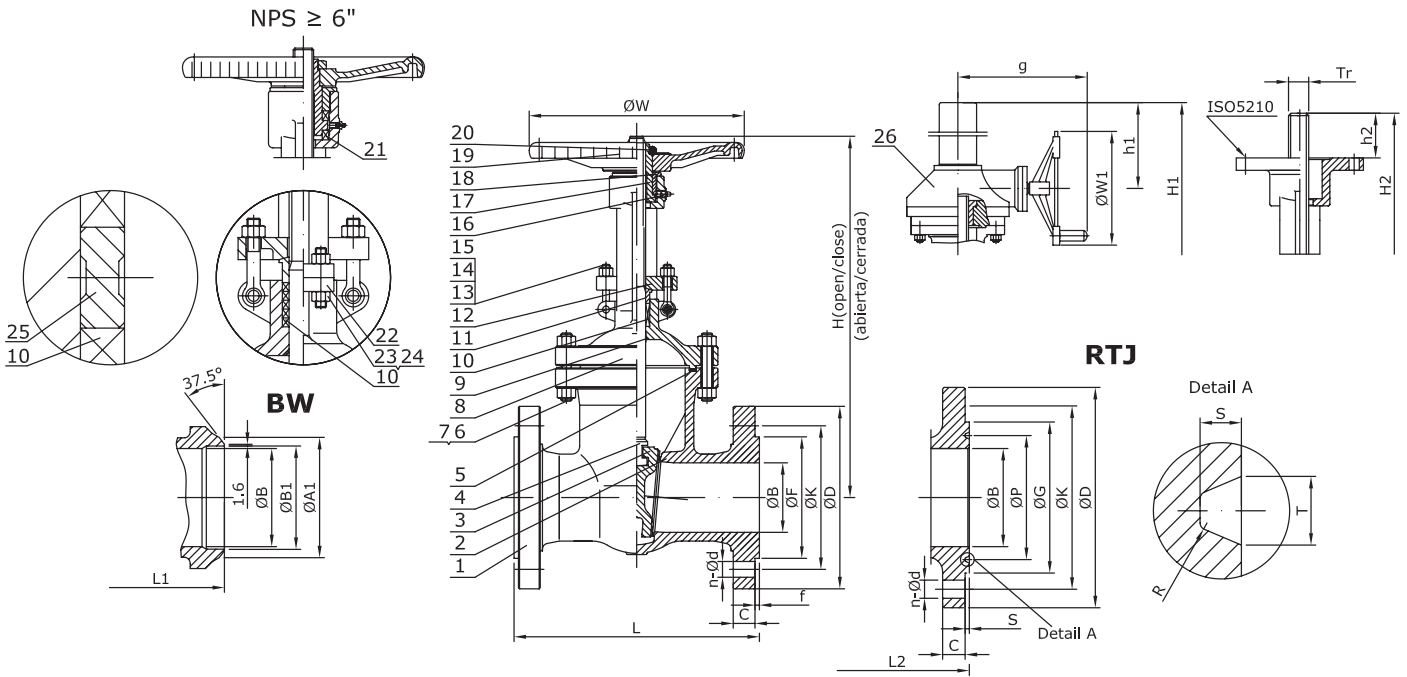

Nº	Part name	CF8 (9012_)	CF8M (9010_)	CF3 (9011_)	CF3M (9017_)
1	Body	A351 CF8	A351 CF8M	A351 CF3	A351 CF3M
2	Seat Ring	Integral SS304	Integral+HF	Integral SS304L	Integral SS316L
3	Wedge	A351 CF8	A351 CF8M	A351 CF3	A351 CF3M
4	Stem	A182 F304	A182 F316	A182 F304L	A182 F316L
5	Gasket	SS304+Graphite	SS316+Graphite	SS316+Graphite	SS316L+Graphite
6	Bonnet Bolt	A193 B8	A193 B8M	A193 B8M	
7	Bonnet Nut	A194 8	A194 8M	A194 8M	
8	Bonnet	A351 CF8	A351 CF8M	A351 CF3	A351 CF3M
9	Backseat Bushing	SS304	SS316	SS304L	SS316L
10	Packing	Graphite		Graphite	
11	Packing Gland	A182 F304	A182 F316	A182 F304L	A182 F316L
12	Gland Flange	A351 CF8	A351 CF8M	A351 CF3	A351 CF3M
13	Eyebolt Pin	A276 304	A276 316	A276 316	
14	Gland Eyebolt	A193 B8	A193 B8M	A193 B8M	
15	Gland Nut	A194 8	A194 8M	A194 8M	
16	Grease Nipple	St. Steel		St. Steel	
17	Stem Nut	A439 D2		A439 D2	
18	Retaining Nut	St. Steel		St. Steel	
19	Handwheel	Steel		Steel	
20	Handwheel Nut	St. Steel		St. Steel	
21	Bearings (1)	Alloy Steel		Alloy Steel	
22	Yoke (1)	A351 CF8	A351 CF8M	A351 CF3	A351 CF3M
23	Yoke Bolt (1)	A193 B8	A193 B8M	A193 B8M	
24	Yoke Nut (1)	A194 8	A194 8M	A194 8M	
25	Lantern Ring (2)	A276 304	A276 316	A276 316	A276 316L
26	Gear	Assembly		Assembly	

(1) 6" and above  
(2) On request

Main Valve Parameters - Class 600

SERIES 90 ANSI RANGE



Nominal Size	inch	2"	2-1/2"	3"	4"	5"	6"	8"	10"	12"	14"	16"		
	DN	50	65	80	100	125	150	200	250	300	350	400		
End connection	RF	L	292	330	356	432	508	559	660	787	838	889	991	
		ØB	51	65,375	76	102	128,25	152	200	248	299	327	375	
		ØD	165	190	210	275	330	355	420	510	560	605	685	
		ØK	127	149,2	168,3	215,9	266,7	292,1	349,2	431,8	489	527	603,2	
		ØF	92,1	104,8	127	157,2	185,7	215,9	269,9	323,8	381	412,8	469,9	
		C	25,4	28,6	31,8	38,1	44,5	47,7	55,6	63,5	66,7	69,9	76,2	
		f	7	7	7	7	7	7	7	7	7	7	7	7
	n-Ød	8 - 3/4	8 - 7/8	8 - 7/8	8 - 1	8 - 1 1/8	12 - 1 1/8	12 - 1/4	16 - 1 3/8	20 - 1 3/8	20 - 1 1/2	20 - 1 5/8		
	BW	L1	292	330	356	432	508	559	660	787	838	889	991	
		Schedule No.(1)	80	-	80	80	-	80	80	80	80	80	80	
		ØB	51	65,375	76	102	128,25	152	200	248	299	327	375	
		ØA1	60,3	-	91	117	-	172	223	278	329	362	413	
		ØB1	49,22	-	73,5	97	-	146,5	193,5	243	289	317,5	363,5	
	RTJ	L2	295	333	359	435	511	562	663	790	841	892	994	
		ØB	51	65,375	76	102	128,25	152	200	248	299	327	375	
		ØD	165	190	210	275	330	355	420	510	560	605	685	
		ØK	127	149,2	168,3	215,9	266,7	292,1	349,2	431,8	489	527	603,2	
		ØG	108	127	146	175	210	241	302	356	413	457	508	
		ØP	82,55	101,6	123,83	149,23	180,98	211,12	269,88	323,85	381	419,1	469,9	
		C	25,4	28,6	31,8	38,1	44,5	47,7	55,6	63,5	66,7	69,9	76,2	
		n-Ød	8 - 3/4	8 - 7/8	8 - 7/8	8 - 1	8 - 1 1/8	12 - 1 1/8	12 - 1/4	16 - 1 3/8	20 - 1 3/8	20 - 1 1/2	20 - 1 5/8	
		T	11,91	11,91	11,91	11,91	11,91	11,91	11,91	11,91	11,91	11,91	11,91	
		S	7,92	7,92	7,92	7,92	7,92	7,92	7,92	7,92	7,92	7,92	7,92	
		R	0,8	0,8	0,8	0,8	0,8	0,8	0,8	0,8	0,8	0,8	0,8	
	Top works/Operation	Hand-wheel	H (open)	428	491	537	641	773	871	1046	1289	-	-	-
			H (close)	367	414	449	528	629	704	830	1019	-	-	-
			ØW	220	255	280	300	329	350	450	600	-	-	-
		Gear with handwheel	H1	-	-	-	-	-	913	1109	1325	1520	1730	1840
h1			-	-	-	-	-	222	278	326	378	453	505	
g			-	-	-	-	-	440	440	440	513	513	513	
ØW1			-	-	-	-	-	310	460	460	460	530	530	
With ISO 5210 mounting pad		H2 (open)	429	491	537	649	769	857	1046	1294	1520	1730	1830	
		H2 (close)	368	415	449	536	625	690	830	1024	1220	1380	1435	
		h2	60	60	60	80	80	80	100	120	140	140	160	
		ISO	F10	F10	F10	F14	F14	F14	F16	F25	F30	F30	F35	
		Tr	Tr22x5LH	Tr26x5LH	Tr26x5LH	Tr30x6LH	Tr38x6LH	Tr38x6LH	Tr42x8LH	Tr48x8LH	Tr52x8LH	Tr58x8LH	Tr62x8LH	
		Stroke	61	76,525	88	113	144,05	167	216	270	300	350	395	
		No. of turns	12	15	18	19	24	28	27	34	38	44	49	
Torque (Nm) (2)		60	78	91	158	291	389	639	1019	1492	1923	2256		
Kvs-value			171	422	607	1111	1996	2650	4701	7252	10983	13137	17239	
Approx. Weight RF (3)			30	44	55	98	156	198	345	630	956	1150	1530	
Approx. Weight BW		23	34	42	75	120	154	281	527	834	970	1302		

(1) Other schedule nos. on request  
 (2) Torque includes 30% of safety factor  
 (3) RTJ weight increases approx. by 10%

Dimensions in mm (except for bolt holes - Ød -, which are in inch units) subject to manufacturing tolerance  
 Kvs-values in m³/h / Torques in Nm / Weights in kg  
 For more information about flanged and welded ends refer to page 16

Main Valve Parameters - Class 600

SERIES 90 ANSI RANGE

Nominal Size	inch	18"	20"	24"	26"	28"	30"	32"	36"	40"	42"	
	DN	450	500	600	650	700	750	800	900	1000	1050	
End connection	RF	L	1092	1194	1397	1448	1549	1651	1778	2083	2149	2260
		ØB	419	464	559	603	648	695	779	874	976	1020
		ØD	745	815	940	1015	1075	1130	1195	1315	1320	1405
		ØK	654	723,9	838,2	914,4	965,2	1022,4	1079,5	1193,8	1212,8	1282,7
		ØF	533,4	584,2	692,2	749	800	857	914	1022	1111	1168
		C	82,6	88,9	101,6	108	111,2	114,3	117,5	123,9	158,8	168,3
		f	7	7	7	7	7	7	7	7	7	7
		n-Ød	20 - 1 3/4	24 - 1 3/4	24 - 2	28 - 2	28 - 2 1/8	28 - 2 1/8	28 - 2 3/8	28 - 2 5/8	32 - 2 3/8	28 - 2 5/8
	BW	L1	1092	1193	1397	1448	1549	1651	1778	2083	2149	2260
		Schedule No.(1)	80	80	80	-	-	-	-	-	-	-
		ØB	419	464	559	603	648	695	779	874	976	1020
		ØA1	464	516	619	-	-	-	-	-	-	-
		ØB1	409,5	455,5	547,5	-	-	-	-	-	-	-
	RTJ	L2	1095	1200	1407	1461	1562	1664	1794	2099	-	-
		ØB	419	464	559	603	648	695	779	874	-	-
		ØD	745	815	940	1015	1075	1130	1195	1315	-	-
		ØK	654	723,9	838,2	914,4	965,2	1022,4	1079,5	1193,8	-	-
		ØG	575	635	749	810	861	917	984	1092	-	-
		ØP	533,4	584,2	692,15	749,3	800,1	857,25	914,4	1022,35	-	-
		C	82,6	88,9	101,6	108	111,2	114,3	117,5	123,9	-	-
n-Ød		20 - 1 3/4	24 - 1 3/4	24 - 2	28 - 2	28 - 2 1/8	28 - 2 1/8	28 - 2 3/8	28 - 2 5/8	-	-	
T		11,91	13,49	16,66	19,84	19,84	19,84	23,01	23,01	-	-	
S		7,92	9,53	11,13	12,7	12,7	12,7	14,27	14,27	-	-	
R		0,8	1,5	1,5	1,5	1,5	1,5	1,5	1,5	-	-	
Top works/Operation		Hand-wheel	H (open)	-	-	-	-	-	-	-	-	-
	H (close)		-	-	-	-	-	-	-	-	-	
	ØW		-	-	-	-	-	-	-	-	-	
	Gear with handwheel	H1	2370	2600	3160	3358	3449	3650	3789	4175	4386	4496
		h1	553	601	653	735	860	923	1015	1206	1459	1565
		g	513	588	588	613	613	613	698	698	698	698
		ØW1	530	600	600	800	800	800	800	800	1000	1000
	With ISO 5210 mounting pad	H2 (open)	2355	2580	2685	2949	3115	3260	-	-	-	-
		H2 (close)	1915	2095	2155	2299	2403	2508	-	-	-	-
		h2	160	160	200	200	250	250	-	-	-	-
		ISO	F35	F35	F40	F40	F48	F48	-	-	-	-
		Tr	Tr65×10LH	Tr70×10LH	Tr76×10LH	Tr85×10LH	Tr90×12LH	Tr100×12LH	-	-	-	-
		Stroke	440	485	530	650	712	752	-	-	-	-
		No. of turns	44	49	53	65	59	63	-	-	-	-
	Torque (Nm) (2)	3082	3833	4652	5885	6300	6952	-	-	-	-	
Kvs-value	22393	27436	39957	48120	56325	64547	72803	97650	133442	168609		
Approx. Weight RF (3)	2110	2500	3900	4600	5200	7000	9800	11200	14300	17200		
Approx. Weight BW	1822	2146	3462	4025	4554	6270	8973	10158	13326	16000		

- (1) Other schedule nos. on request
- (2) Torque includes 30% of safety factor
- (3) RTJ weight increases approx. by 10%

Dimensions in mm (except for bolt holes - Ød -, which are in inch units) subject to manufacturing tolerance  
 Kvs-values in m<sup>3</sup>/h / Torques in Nm / Weights in kg  
 For more information about flanged and welded ends refer to page 16

Main Parts and Materials

SERIES 90 ANSI RANGE  
Class 900

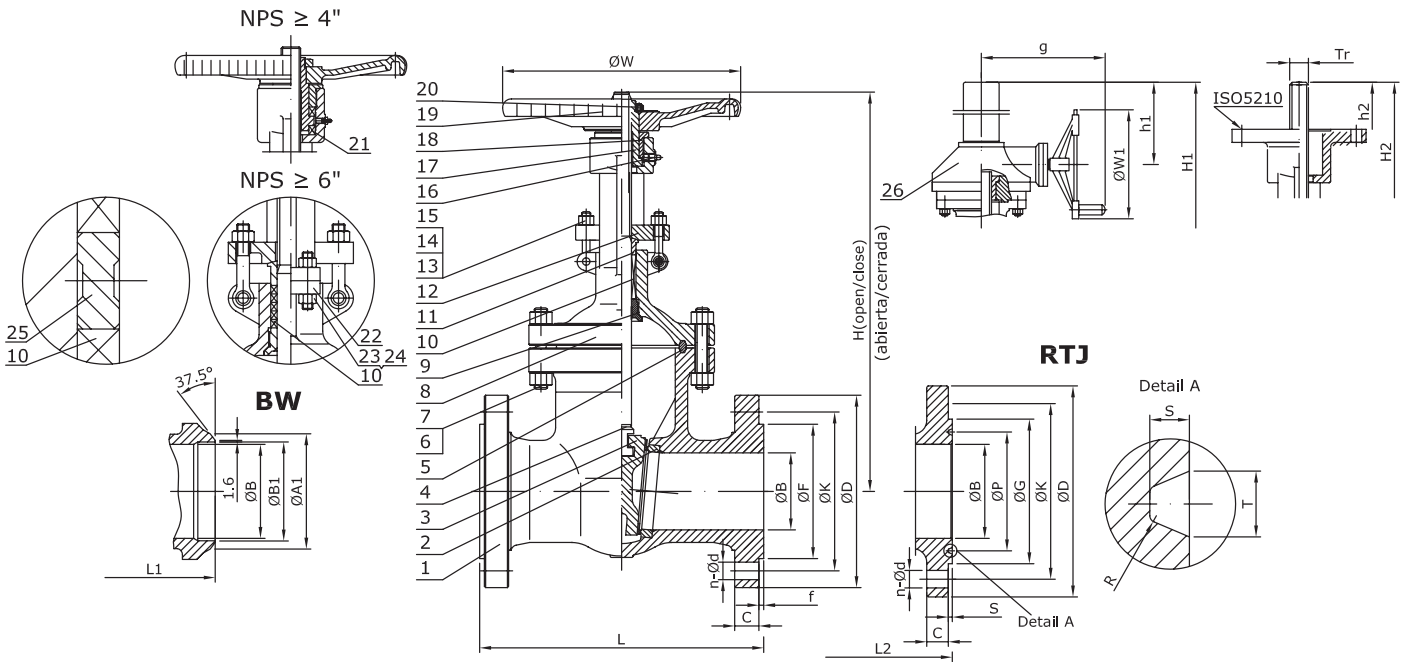

Nº	Part name	A216 WCB (90A0_)	A352 LCB		A217 WC1 (90B1_)	A217 WC6 (90B8_)	A217 WC9 (90B9_)	A217 C5 (90C2_)	A217 C12 (90C4_)
			Trim 15 (90A8K_)	Trim 16 (90A8L_)					
1	Body	A216 WCB	A352 LCB		A217 WC1	A217 WC6	A217 WC9	A217 C5	A217 C12
2	Seat Ring	A105	A182 F304+HF	A182 F316+HF	A182 F1+HF	A182 F11+HF	A182 F22+HF	A182 F5+HF	A182 F9+HF
3	Wedge	A216 WCB	A351 CF8+HF	A351 CF8M+HF	A217 WC1+HF	A217 WC6+HF	A217 WC9+HF	A217 C5+HF	A217 C12+HF
4	Stem	A182 F6a	A182 F304	Nitronic 50	A182 F6a	A182 F6a	A182 F6a	A182 F6a	A182 F6a
5	Gasket	SS304	SS304		SS304		SS304+Graphite		
6	Bonnet Bolt	A193 B7	A320 L7		A193 B16		A193 B16		
7	Bonnet Nut	A194 2H	A194 4		A194 4		A194 4		
8	Bonnet	A216 WCB	A352 LCB		A217 WC1	A217 WC6	A217 WC9	A217 C5	A217 C12
9	Backseat Bushing	A182 F6a	A182 F304	A182 F316	A182 F6a		A182 F6a	A182 F6a	A182 F6a
10	Packing	Graphite	Graphite		Graphite		Graphite		
11	Packing Gland	A182 F6a	A182 F304		A182 F6a		A182 F6a		
12	Gland Flange	A216 WCB	A352 LCB		A217 WC1	A217 WC6	A217 WC9	A217 C5	A217 C12
13	Eyebolt Pin	AISI 1025	AISI 1025		A276 410		A276 410		
14	Gland Eyebolt	A193 B7	A320 L7		A193 B16		A193 B16		
15	Gland Nut	A194 2H	A194 4		A194 4		A194 4		
16	Grease Nipple	Carbon Steel	Carbon Steel		Alloy Steel		Alloy Steel		
17	Stem Nut	A439 D2	A439 D2		A439 D2		A439 D2		
18	Retaining Nut	Carbon Steel	Carbon Steel		Carbon Steel		Carbon Steel		
19	Handwheel	Steel	Steel		Steel		Steel		
20	Handwheel Nut	Carbon Steel	Carbon Steel		Carbon Steel		Carbon Steel		
21	Bearings (1)	Alloy Steel	Alloy Steel		Alloy Steel		Alloy Steel		
22	Yoke (2)	A216 WCB	A352 LCB		A217 WC1	A217 WC6	A217 WC9	A217 C5	A217 C12
23	Yoke Bolt (2)	A193 B7	A320 L7		A193 B16		A193 B16		
24	Yoke Nut (2)	A194 2H	A194 4		A194 4		A194 4		
25	Lantern Ring (3)	A276 410	A276 304		A276 410		A276 410		
26	Gear	Assembly	Assembly		Assembly		Assembly		

(1) Class 900: 4" and above; (2) Class 900: 6" and above; (3) On request

Fig. 90A0_	Seat Surface	Wedge Surface	Stem
TRIM #1 (90A01)	A105+13Cr	A216 WCB+13Cr	A182 F6a
TRIM #5 (90A05)	A105+HF	A216 WCB+HF	A182 F6a
TRIM #8 (90A08)	A105+HF	A216 WCB+13Cr	A182 F6a

HF = Hard faced



Main Valve Parameters - Class 900

SERIES 90 ANSI RANGE

Nominal Size	inch	2"	2-1/2"	3"	4"	5"	6"	8"	10"	12"	
	DN	50	65	80	100	125	150	200	250	300	
End connection	RF	L	368	419	381	457	559	610	737	838	965
		ØB	48	62,375	73	98	123,2	146	191	238	282
		ØD	215	245	240	290	350	380	470	545	610
		ØK	165,1	190,5	190,5	235	279,4	317,5	393,7	469,9	533,4
		ØF	92,1	104,8	127	157,2	185,7	215,9	269,9	323,8	381
		C	38,1	41,3	38,1	44,5	50,8	55,6	63,5	69,9	79,4
		f	7	7	7	7	7	7	7	7	7
		n-Ød	8 - 7/8	8 - 1	8 - 7/8	8 - 1 1/8	8 - 1 1/4	12 - 1 1/8	12 - 1 3/8	16 - 1 3/8	20 - 1 3/8
	BW	L1	368		381	457		610	737	838	965
		Schedule No.(1)	160	-	160	120	-	120	100	100	100
		ØB	48	62,375	73	98	123,2	146	191	238	282
		ØA1	60,3	-	91	117	-	172	223	278	329
		ØB1	38,16	-	66,5	92	-	140	189	236,5	281
	RTJ	L2	371	422	384	460	562	613	740	841	968
		ØB	48	62,375	73	98	123,2	146	191	238	282
		ØD	215	245	240	290	350	380	470	545	610
		ØK	165,1	190,5	190,5	235	279,4	317,5	393,7	469,9	533,4
		ØG	124	137	156	181	216	241	308	362	419
		ØP	95,25	107,95	123,83	149,23	180,98	211,12	269,88	323,85	381
		C	38,1	41,3	38,1	44,5	50,8	55,6	63,5	69,9	79,4
n-Ød		8 - 7/8	8 - 1	8 - 7/8	8 - 1 1/8	8 - 1 1/4	12 - 1 1/8	12 - 1 3/8	16 - 1 3/8	20 - 1 3/8	
T		11,91	11,91	11,91	11,91	11,91	11,91	11,91	11,91	11,91	
S		7,92	7,92	7,92	7,92	7,92	7,92	7,92	7,92	7,92	
R		0,8	0,8	0,8	0,8	0,8	0,8	0,8	0,8	0,8	
Top works/Operation		Hand-wheel	H (open)	516	601	663	770	-	-	-	-
	H (close)		471	539	590	673	-	-	-	-	-
	ØW		250	279	300	350	-	-	-	-	-
	Gear with handwheel	H1	-	-	-	-	-	1035	1195	1354	1562
		h1	-	-	-	-	-	228	278	341	385
		g	-	-	-	-	-	440	440	513	513
		ØW1	-	-	-	-	-	460	460	530	530
	With ISO 5210 mounting pad	H2 (open)	510	611	686	770	825	865	965	1280	1482
		H2 (close)	466	551	613	673	697	715	768	1042	1175
		h2	60	72	80	80	103	120	120	140	140
		ISO	F10	F14	F14	F14	F25	F25	F25	F30	F30
		Tr	Tr26×5LH	Tr30×6LH	Tr30×6LH	Tr32×6LH	Tr42×8LH	Tr42×8LH	Tr48×8LH	Tr55×8LH	Tr58×8LH
		Stroke	44	61	73	97	127	150	197	238	307
		No. of turns	9	10	12	16	16	19	25	30	38
	Torque (Nm) (2)	105	128	145	240	565	805	1162	1485	1806	
	Kvs-value		132	376	556	1026	1837	2436	4295	6709	9829
	Approx. Weight RF (3)		100	114	125	170	311	415	620	880	1400
	Approx. Weight BW		86	99	108	142	265	355	518	738	1204

(1) Other schedule nos. on request  
 (2) Torque includes 30% of safety factor  
 (3) RTJ weight increases approx. by 10%

Dimensions in mm (except for bolt holes - Ød -, which are in inch units) subject to manufacturing tolerance  
 Kvs-values in m³/h / Torques in Nm / Weights in kg  
 For more information about flanged and welded ends refer to page 16



Main Valve Parameters - Class 900

SERIES 90 ANSI RANGE

Nominal Size		inch	14"	16"	18"	20"	24"	26"	28"	30"	
DN			350	400	450	500	600	650	700	750	
End connection	RF	L	1029	1130	1219	1321	1549	1574	1663	1778	
		ØB	311	356	400	445	533	578	622	667	
		ØD	640	705	785	855	1040	1085	1170	1230	
		ØK	558,8	616	685,8	749,3	901,7	952,5	1022,4	1085,8	
		ØF	412,8	469,9	533,4	584,2	692,2	749	800	857	
		C	85,8	88,9	101,6	108	139,7	139,7	142,9	149,3	
		f	7	7	7	7	7	7	7	7	
		n-Ød	20 - 1 1/2	20 - 1 5/8	20 - 1 7/8	20 - 2	20 - 2 1/2	20 - 2 7/8	20 - 3 1/8	20 - 3 1/8	
	BW	L1	1029	1130	1219	1321	1549	1574	1663	1778	
		Schedule No.(1)	100	100	100	100	100	-	-	-	
		ØB	311	356	400	445	533	578	622	667	
		ØA1	362	413	464	516	619	-	-	-	
		ØB1	308	354	398,5	443	532	-	-	-	
	RTJ	L2	1039	1140	1232	1334	1568	-	-	-	
		ØB	311	356	400	445	533	578	622	667	
		ØD	640	705	785	855	1040	1085	1170	1230	
		ØK	558,8	616	685,8	749,3	901,7	952,5	1022,4	1085,8	
		ØG	467	524	594	648	772	832	889	946	
		ØP	419,1	469,9	533,4	584,2	692,15	749,3	800,1	857,25	
		C	85,8	88,9	101,6	108	139,7	139,7	142,9	149,3	
		n-Ød	20 - 1 1/2	20 - 1 5/8	20 - 1 7/8	20 - 2	20 - 2 1/2	20 - 2 7/8	20 - 3 1/8	20 - 3 1/8	
		T	16,66	16,66	19,84	19,84	26,97	30,18	33,32	33,32	
		S	11,13	11,13	12,7	12,7	15,88	17,48	17,48	17,48	
		R	1,5	1,5	1,5	1,5	2,4	2,3	2,3	2,3	
		Top works/Operation	Hand-wheel	H (open)	-	-	-	-	-	-	-
	H (close)			-	-	-	-	-	-	-	-
	ØW			-	-	-	-	-	-	-	-
	Gear with handwheel		H1	1804	2062	2232	2334	2489	2946	3251	3454
h1			458	503	615	723	916	1015	1150	1235	
g			513	513	588	588	613	613	698	698	
ØW1			600	600	600	600	800	800	800	1000	
With ISO 5210 mounting pad	H2 (open)		1654	1917	2348	2452	2536	-	-	-	
	H2 (close)		1343	1737	1997	2056	2142	-	-	-	
	h2		160	160	160	200	200	-	-	-	
	ISO		F35	F35	F35	F40	F40	-	-	-	
	Tr		Tr62×8LH	Tr65×10LH	Tr70×10LH	Tr76×10LH	Tr85×10LH	-	-	-	
	Stroke		311	180	351	396	394	-	-	-	
	No. of turns		39	18	35	40	39	-	-	-	
Torque (Nm) (2)	2235		2980	3675	4555	5760	-	-	-		
Kvs-value				11880	15513	20436	25256	36385	44587	51709	59361
Approx. Weight RF (3)				1620	2300	3800	5200	6300	7000	9800	14500
Approx. Weight BW			1397	2031	3440	4752	5484	6087	8716	13264	

(1) Other schedule nos. on request  
 (2) Torque includes 30% of safety factor  
 (3) RTJ weight increases approx. by 10%

Dimensions in mm (except for bolt holes - Ød -, which are in inch units) subject to manufacturing tolerance  
 Kvs-values in m³/h / Torques in Nm / Weights in kg  
 For more information about flanged and welded ends refer to page 16

Main Parts and Materials

SERIES 91 ANSI RANGE  
Class 1500&2500

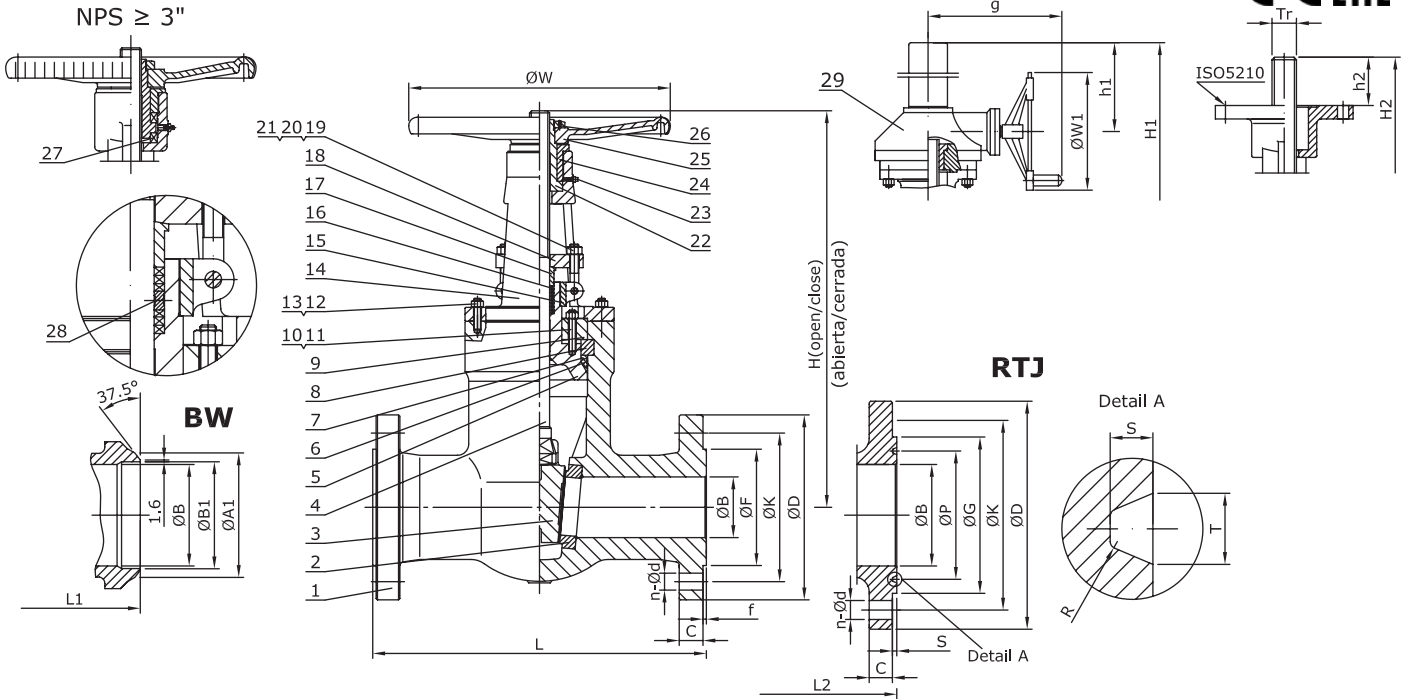

Nº	Part name	A216 WCB (90A0_)	A352 LCB		A217 WC1 (90B1_)	A217 WC6 (90B8_)	A217 WC9 (90B9_)	A217 C5 (90C2_)	A217 C12 (90C4_)
			Trim 15 (90A8K_)	Trim 16 (90A8L_)					
1	Body	A216 WCB	A352 LCB		A217 WC1	A217 WC6	A217 WC9	A217 C5	A217 C12
2	Seat Ring	A105	A182 F304+HF	A182 F316+HF	A182 F1+HF	A182 F11+HF	A182 F22+HF	A182 F5+HF	A182 F9+HF
3	Wedge	A216 WCB	A351 CF8+HF	A351 CF8M+HF	A217 WC1+HF	A217 WC6+HF	A217 WC9+HF	A217 C5+HF	A217 C12+HF
4	Stem	A182 F6a	A182 F304	Nitronic 50	A182 F6a	A182 F6a	A182 F6a	A182 F6a	A182 F6a
5	Bonnet	A105	A350 LF2		A182 F1	A182 F11	A182 F22	A217 C5	
6	Gasket	SS304 +Graphite	SS304 +Graphite			SS304 +Graphite		A182 F5+HF	
7	Gasket Washer	A182 F6a	A182 F304			A182 F6a		A217 C5+HF	
8	Split Ring	A105	A350 LF2		A182 F1	A182 F11	A182 F22	A182 F6a	A182 F6a
9	Retainer Ring	A105	A350 LF2		A182 F1	A182 F11	A182 F22	A182 F5	A182 F9
10	Screw	A193 B7	A320 L7			A193 B16		SS304+Graphite	
11	Nut	A194 2H	A194 4			A194 4		A182 F6a	
12	Bolt	A193 B7	A320 L7			A193 B16		A182 F5	
13	Nut	A194 2H	A194 4			A194 4		A182 F5	
14	Yoke	A216 WCB	A352 LCB		A217 WC1	A217 WC6	A217 WC9	A193 B16	
15	Ear Seat	A216 WCB	A352 LCB		A217 WC1	A217 WC6	A217 WC9	A194 4	
16	Packing	Graphite	Graphite			Graphite		Graphite	
17	Packing Gland	A182 F6a	A182 F304			A182 F6a		A182 F6a	
18	Gland Flange	A216 WCB	A352 LCB		A217 WC1	A217 WC6	A217 WC9	A217 C5	
19	Eyebolt Pin	AISI 1025	AISI 1025			A276 410		A276 410	
20	Gland Eyebolt	A193 B7	A320 L7			A193 B16		A193 B16	
21	Gland Nut	A194 2H	A194 4			A194 4		A194 4	
22	Stem Nut	A439 D2	A439 D2			A439 D2		A439 D2	
23	Grease Nipple	Carbon Steel	Carbon Steel			Alloy Steel		Alloy Steel	
24	Retaining Nut	Carbon Steel	Carbon Steel			Carbon Steel		Carbon Steel	
25	Handwheel	Steel	Steel			Steel		Steel	
26	Handwheel Nut	Carbon Steel	Carbon Steel			Carbon Steel		Carbon Steel	
27	Bearings (1)	Alloy Steel	Alloy Steel			Alloy Steel		Alloy Steel	
28	Lantern Ring (2)	A276 410	A276 304			A276 410		A276 410	
29	Gear	Assembly	Assembly			Assembly		Assembly	

(1) 3" and above ;(2) On request

Fig. 91A0_	Seat Surface	Wedge Surface	Stem
TRIM #1 (91A01)	A105+13Cr	A216 WCB+13Cr	A182 F6a
TRIM #5 (91A05)	A105+HF	A216 WCB+HF	A182 F6a
TRIM #8 (91A08)	A105+HF	A216 WCB+13Cr	A182 F6a

HF = Hard faced

Information / restriction of technical rules need to be observed!  
Installation, Operating and Maintenance Manual can be downloaded at [www.comeval.es](http://www.comeval.es)

The engineer, designing a system or a plant, is responsible for the selection of the correct valve  
Product suitability must be verified, contact manufacturer for information

Main Parts and Materials

SERIES 91 ANSI RANGE  
Class 1500&2500

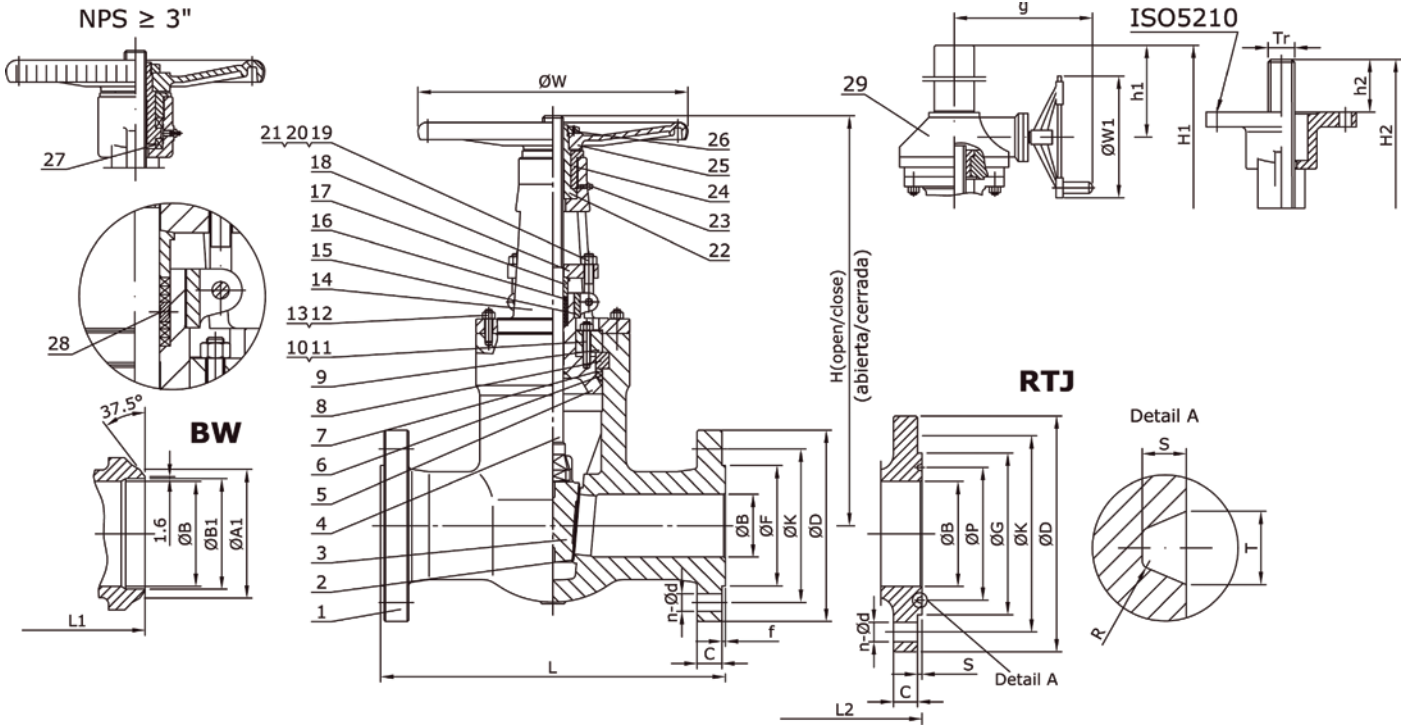

Nº	Part name	CF8 (9112_)	CF8M (9110_)	CF3 (9111_)	CF3M (9117_)
1	Body	A351 CF8	A351 CF8M	A351 CF3	A351 CF3M
2	Seat Ring	Integral+HF	Integral SS316	Integral+HF	Integral+HF
3	Wedge	A351 CF8+HF	A351 CF8M	A351 CF3+HF	A351 CF3M+HF
4	Stem	A182 F304	A182 F316	A182 F304L	Nitronic 50
5	Bonnet	A182 F304	A182 F316	A182 F304L	A182 F316L
6	Gasket	SS304+Graphite	SS316+Graphite	SS316+Graphite	SS316L+Graphite
7	Gasket Washer	A182 F304	A182 F316	A182 F304L	A182 F316L
8	Split Ring	A182 F304	A182 F316	A182 F304L	A182 F316L
9	Retainer Ring	A182 F304	A182 F316	A182 F304L	A182 F316L
10	Screw	A193 B8		A193 B8M	
11	Nut	A194 8	A194 8M	A194 8M	
12	Bolt	A193 B8	A193 B8M	A193 B8M	
13	Nut	A194 8	A194 8M	A194 8M	
14	Yoke	A351 CF8	A351 CF8M	A351 CF3	A351 CF3M
15	Ear Seat	A351 CF8	A351 CF8M	A351 CF3	A351 CF3M
16	Packing	Graphite		Graphite	
17	Packing Gland	A182 F304		A182 F304L	A182 F316L
18	Gland Flange	A351 CF8		A351 CF3	A351 CF3M
19	Eyebolt Pin	A276 304		A276 316	
20	Gland Eyebolt	A193 B8		A193 B8M	
21	Gland Nut	A194 8		A194 8M	
22	Stem Nut	A439 D2		A439 D2	
23	Grease Nipple	St. Steel		St. Steel	
24	Retaining Nut	St. Steel		St. Steel	
25	Handwheel	Steel		Steel	
26	Handwheel Nut	St. Steel		St. Steel	
27	Bearings (1)	Alloy Steel		Alloy Steel	
28	Lantern Ring (2)	A276 304		A276 316	A276 316L
29	Gear	Assembly		Assembly	

(1) 3" and above  
(2) On request

Main Valve Parameters - Class 1500

Nominal Size		inch	2"	2-1/2"	3"	4"	5"	6"	8"	10"	
DN			50	65	80	100	125	150	200	250	
End connection	RF	L	368	419	470	546	673	705	832	991	
		ØB	48	60,65	70	92	115,1	136	178	222	
		ØD	215	245	265	310	375	395	485	585	
		ØK	165,1	190,5	203,2	241,3	292,1	317,5	393,7	482,6	
		ØF	92,1	104,8	127	157,2	185,7	215,9	269,9	323,8	
		C	38,1	41,3	47,7	54	73,1	82,6	92,1	108	
		f	7	7	7	7	7	7	7	7	
		n-Ød	8 - 7/8	8 - 1	8 - 1 1/4	8 - 1 3/8	8 - 1 5/8	12 - 1 1/2	12 - 1 3/4	12 - 2	
	BW	L1	368	419	470	546	673	705	832	991	
		Schedule No.(1)	160	-	160	120	-	120	120	120	
		ØB	48	60,65	70	92	115,1	136	178	222	
		ØA1	60,3	-	91	117	-	172	223	278	
		ØB1	38,16	-	66,5	92	-	140	182,5	230	
	RTJ	L2	371	422	473	549	676	711	842	1001	
		ØB	48	60,65	70	92	115,1	136	178	222	
		ØD	215	245	265	310	375	395	485	585	
		ØK	165,1	190,5	203,2	241,3	292,1	317,5	393,7	482,6	
		ØG	124	137	168	194	229	248	318	371	
		ØP	95,25	107,95	136,53	161,93	193,68	211,14	269,88	323,85	
		C	38,1	41,3	47,7	54	73,1	82,6	92,1	108	
		n-Ød	8 - 7/8	8 - 1	8 - 1 1/4	8 - 1 3/8	8 - 1 5/8	12 - 1 1/2	12 - 1 3/4	12 - 2	
		T	11,91	11,91	11,91	11,91	11,91	13,49	16,66	16,66	
		S	7,92	7,92	7,92	7,92	7,92	9,53	11,13	11,13	
	R	0,8	0,8	0,8	0,8	0,8	1,5	1,5	1,5		
	Top works/Operation	Hand-wheel	H (open)	516	629	713	853	-	-	-	-
			H (close)	471	549	607	756	-	-	-	-
			ØW	250	336	400	450	-	-	-	-
		Gear with handwheel	H1	-	-	-	802	941	1043	1179	1419
h1			-	-	-	162	192	214	281	367	
g			-	-	-	440	440	440	513	513	
ØW1			-	-	-	310	396	460	530	600	
With ISO 5210 mounting pad		H2 (open)	518	632	716	863	949	1012	1444	1635	
		H2 (close)	476	553	610	766	851	914	1244	1385	
		h2	60	72	80	80	103	120	140	180	
		ISO	F10	F14	F14	F14	F25	F25	F30	F35	
		Tr	Tr26×5LH	Tr32×6LH	Tr32×6LH	Tr36×6LH	Tr46×8LH	Tr46×8LH	Tr55×8LH	Tr65×10LH	
		Stroke	42	79	106	97	98	98	200	250	
		No. of turns	8	13	18	16	12	12	25	25	
Torque (Nm) (2)		189	241	279	555	748	890	1333	2851		
Kvs-value			171	368	513	915	1617	2137	3735	5855	
Approx. Weight RF (3)			100	140	170	240	438	585	830	1650	
Approx. Weight BW			86	119	144	204	375	501	687	1405	

(1) Other schedule nos. on request  
 (2) Torque includes 30% of safety factor  
 (3) RTJ weight increases approx. by 10%

Dimensions in mm (except for bolt holes - Ød -, which are in inch units) subject to manufacturing tolerance  
 Kvs-values in m<sup>3</sup>/h / Torques in Nm / Weights in kg  
 For more information about flanged and welded ends refer to page 16

Main Valve Parameters - Class 1500

Nominal Size		inch	12"	14"	16"	18"	20"	24"	26"	28"	
DN			300	350	400	450	500	600	650	700	
End connection	RF	L	1130	1257	1384	1537	1664	1943	3032	2209	
		ØB	263	289	330	371	416	498	540	584	
		ØD	675	750	825	915	985	1170	(4)	(4)	
		ØK	571,5	635	704,8	774,7	831,8	990,6	(4)	(4)	
		ØF	381	412,8	469,9	533,4	584,2	692,2	749	800	
		C	123,9	133,4	146,1	162	177,8	203,2	(4)	(4)	
		f	7	7	7	7	7	7	7	7	
		n-Ød	16 - 2 1/8	16 - 2 3/8	16 - 2 5/8	16 - 2 7/8	16 - 3 1/8	16 - 3 5/8	(4)	(4)	
	BW	L1	1130	1257	1384	1537	1664	1943	3032	2209	
		Schedule No.(1)	120	120	120	120	120	120	-	-	
		ØB	263	289	330	371	416	498	540	584	
		ØA1	329	362	413	464	516	619	-	-	
		ØB1	273	300	344,5	387,5	432	517,5	-	-	
	RTJ	L2	1146	1276	1406	1559	1686	1971	-	-	
		ØB	263	289	330	371	416	498	-	-	
		ØD	675	750	825	915	985	1170	-	-	
		ØK	571,5	635	704,8	774,7	831,8	990,6	-	-	
		ØG	438	489	546	613	673	794	-	-	
		ØP	381	419,1	469,9	533,4	584,2	692,15	-	-	
		C	123,9	133,4	146,1	162	177,8	203,2	-	-	
n-Ød		16 - 2 1/8	16 - 2 3/8	16 - 2 5/8	16 - 2 7/8	16 - 3 1/8	16 - 3 5/8	-	-		
T		23,01	26,97	30,18	30,18	33,32	36,53	-	-		
S		14,27	15,88	17,48	17,48	17,48	20,62	-	-		
R		1,5	2,4	2,4	2,4	2,4	2,4	-	-		
Top works/Operation		Hand-wheel	H (open)	-	-	-	-	-	-	-	-
	H (close)		-	-	-	-	-	-	-	-	
	ØW		-	-	-	-	-	-	-	-	
	Gear with handwheel	H1	1910	1980	2035	2107	2209	2387	2794	2850	
		h1	408	436	477	518	625	736	888	1002	
		g	588	588	588	613	613	698	698	698	
		ØW1	600	600	600	600	800	800	1000	1000	
	With ISO 5210 mounting pad	H2 (open)	1806	2081	2342	2619	-	-	-	-	
		H2 (close)	1506	1789	1981	2209	-	-	-	-	
		h2	180	220	220	220	-	-	-	-	
		ISO	F35	F40	F40	F40	-	-	-	-	
		Tr	Tr70×10LH	Tr76×10LH	Tr76×10LH	Tr85×12LH	-	-	-	-	
		Stroke	300	292	361	410	-	-	-	-	
		No. of turns	30	29	36	34	-	-	-	-	
	Torque (Nm) (2)	3505	4322	4650	6500	-	-	-	-		
	Kvs-value			8530	10256	13397	17641	22120	26645	38901	45573
	Approx. Weight RF (3)			2100	2800	3850	5225	6310	9050	-	-
	Approx. Weight BW			1736	2289	3170	4341	5194	7238	-	-

(1) Other schedule nos. on request  
 (2) Torque includes 30% of safety factor  
 (3) RTJ weight increases approx. by 10%  
 (4) NPS26 & NPS28 acc.to the agreed between the customer and the supplier

Dimensions in mm (except for bolt holes - Ød -, which are in inch units) subject to manufacturing tolerance  
 Kvs-values in m<sup>3</sup>/h / Torques in Nm / Weights in kg  
 For more information about flanged and welded ends refer to page 16

Main Valve Parameters - Class 2500

SERIES 91 ANSI RANGE

Nominal Size	inch	2"	2-1/2"	3"	4"	5"	6"	8"	10"	12"		
	DN	50	65	80	100	125	150	200	250	300		
End connection	RF	L	451	508	578	673	794	914	1022	1270	1422	
		ØB	38	48,925	57	73	92,95	111	146	184	219	
		ØD	235	265	305	355	420	485	550	675	760	
		ØK	171,4	196,8	228,6	273	323,8	368,3	438,2	539,8	619,1	
		ØF	92,1	104,8	127	157,2	185,7	215,9	269,9	323,8	381	
		C	50,9	57,2	66,7	76,2	92,1	108	127	165,1	184,2	
		f	7	7	7	7	7	7	7	7	7	
		n-Ød	8 - 1 1/8	8 - 1 1/4	8 - 1 3/8	8 - 1 5/8	8 - 1 7/8	8 - 2 1/8	12 - 2 1/8	12 - 2 5/8	12 - 2 7/8	
	BW	L1	451	508	578	673	794	914	1022	1270	1422	
		Schedule No.(1)	160	-	160	160	-	160	160	160	160	
		ØB	38	48,925	57	73	92,95	111	146	184	219	
		ØA1	60,3	-	91	117	-	172	223	278	329	
		ØB1	42,82	-	66,5	87,5	-	132	173	216	257	
	RTJ	L2	454	514	584	683	807	927	1038	1292	1444	
		ØB	38	48,925	57	73	92,95	111	146	184	219	
		ØD	235	265	305	355	420	485	550	675	760	
		ØK	171,4	196,8	228,6	273	323,8	368,3	438,2	539,8	619,1	
		ØG	133	149	168	203	241	279	340	425	495	
		ØP	101,6	111,13	127	157,18	190,5	228,6	279,4	342,9	406,4	
		C	50,9	57,2	66,7	76,2	92,1	108	127	165,1	184,2	
		n-Ød	8 - 1 1/8	8 - 1 1/4	8 - 1 3/8	8 - 1 5/8	8 - 1 7/8	8 - 2 1/8	12 - 2 1/8	12 - 2 5/8	12 - 2 7/8	
		T	11,91	13,49	13,49	16,66	19,84	19,84	23,01	30,18	33,32	
		S	7,92	9,53	9,53	11,13	12,7	12,7	14,27	17,48	17,48	
	R	0,8	1,5	1,5	1,5	1,5	1,5	1,5	2,4	2,4		
	Top works/Operation	Hand-wheel	H (open)	630	722	790	900	-	-	-	-	-
			H (close)	590	661	713	806	-	-	-	-	-
			ØW	400	458	500	600	-	-	-	-	-
		Gear with handwheel	H1	590	701	783	915	1110	1254	1374	1685	1890
h1			185	194	200	306	349	381	435	467	512	
g			325	346	362	362	407	440	513	588	613	
ØW1			310	310	310	460	460	460	530	530	600	
With ISO 5210 mounting pad		H2 (open)	630	723	792	947	1046	1120	1202	1373	1542	
		H2 (close)	590	662	715	853	921	971	1003	1125	1242	
		h2	60	72	80	80	103	120	180	250	250	
		ISO	F10	F14	F14	F14	F25	F25	F35	F40	F40	
		Tr	Tr26×5LH	Tr30×6LH	Tr32×6LH	Tr36×6LH	Tr48×8LH	Tr48×8LH	Tr62×8LH	Tr76×10LH	Tr85×12LH	
		Stroke	40	61	77	94	126	149	199	248	300	
		No. of turns	8	10	13	16	16	19	25	25	25	
Torque (Nm) (2)		170	217	251	583	943	1209	2445	4212	6205		
Kvs-value		140	195	235	393	708	940	1684	2675	3876		
Approx. Weight RF (3)		121	164	195	230	512	720	1295	2250	4200		
Approx. Weight BW		98	124	143	151	359	514	1264	1668	3370		

(1) Other schedule nos. on request  
 (2) Torque includes 30% of safety factor  
 (3) RTJ weight increases approx. by 10%

Dimensions in mm (except for bolt holes - Ød -, which are in inch units) subject to manufacturing tolerance  
 Kvs-values in m³/h / Torques in Nm / Weights in kg  
 For more information about flanged and welded ends refer to page 16

Gate Valve with AUMA Actuator

