

CAST IRON SWING CHECK VALVE PN16



Lloyd's
Register
PED/2014/68/EU



Certificate 3.1

Size : DN 40 to 300
Ends : PN16 flanges R.F.
Min Temperature : - 10°C
Max Temperature : + 80°C with EPDM seat, 120°C with Metal seat
Max Pressure : 16 Bars
Specifications : Swing check type
Vertical or horizontal position
Bolted bonnet

Materials : Cast iron body EN GJL-250

CAST IRON SWING CHECK VALVE PN16

SPECIFICATIONS :

- Swing check type
- Vertical position with ascendant fluid or horizontal position (respect the flow direction indicated by the arrow)
- PN16 flanges R.F.
- Bolted bonnet

USE :

- Heating, water distribution and watering
- Min and max Temperature Ts : - 10°C to + 120°C for metal seat type **Ref.360**
- Min and max Temperature Ts : - 10°C to + 80°C for EPDM seat type **Ref.362**
- Max pressure Ps : 16 bars
- **Do not use with pulsatory speed**
- **Max Speed : 3 M. / Sec.**

HEAD LOSS GRAPH :

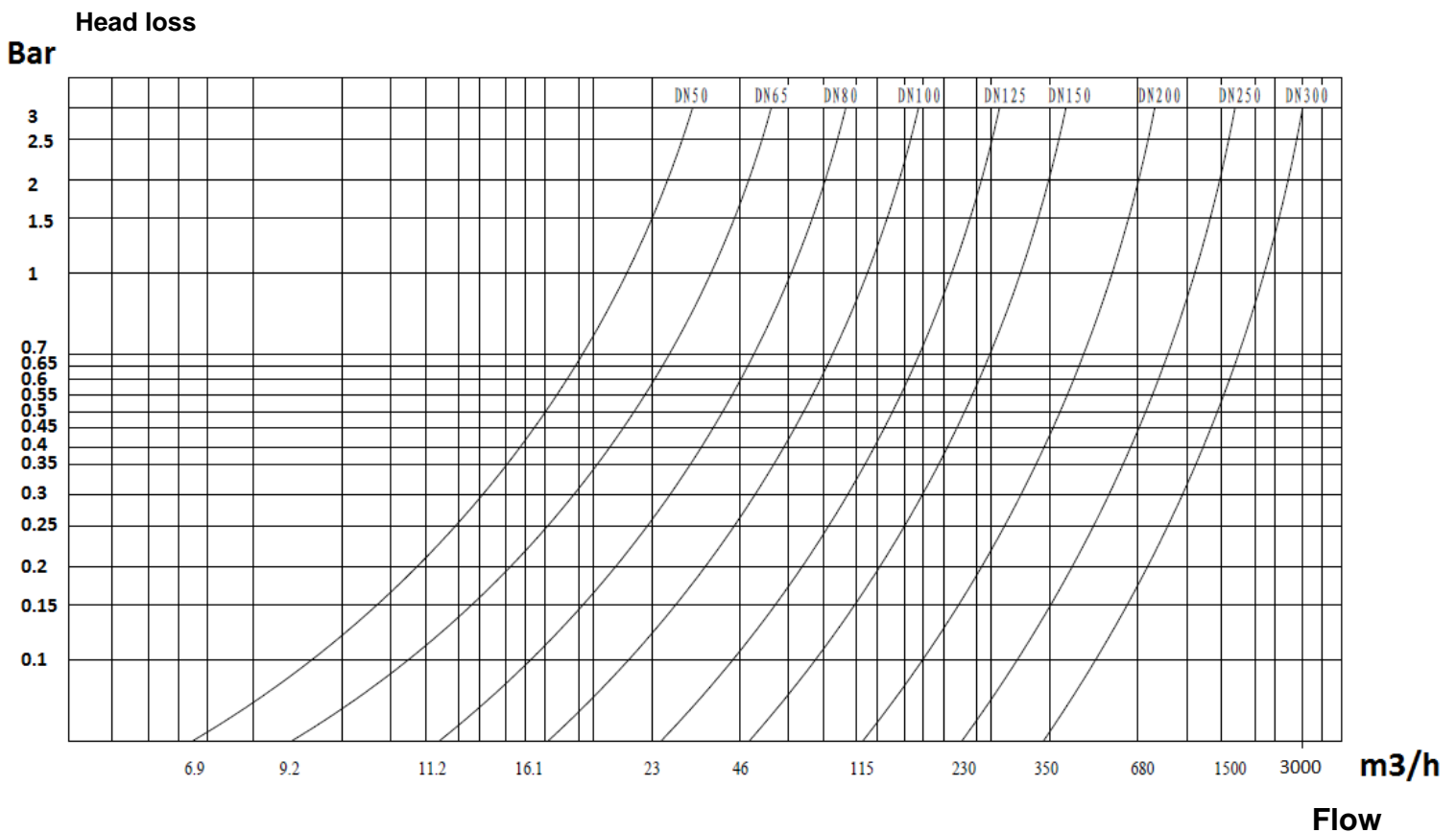

CAST IRON SWING CHECK VALVE PN16

RANGE :

- Cast iron body with metal seat PN16 R.F. flanges **Ref. 360** from DN40 to 300
- Cast iron body with EPDM seat PN16 R.F. flanges **Ref. 362** from DN40 to 200

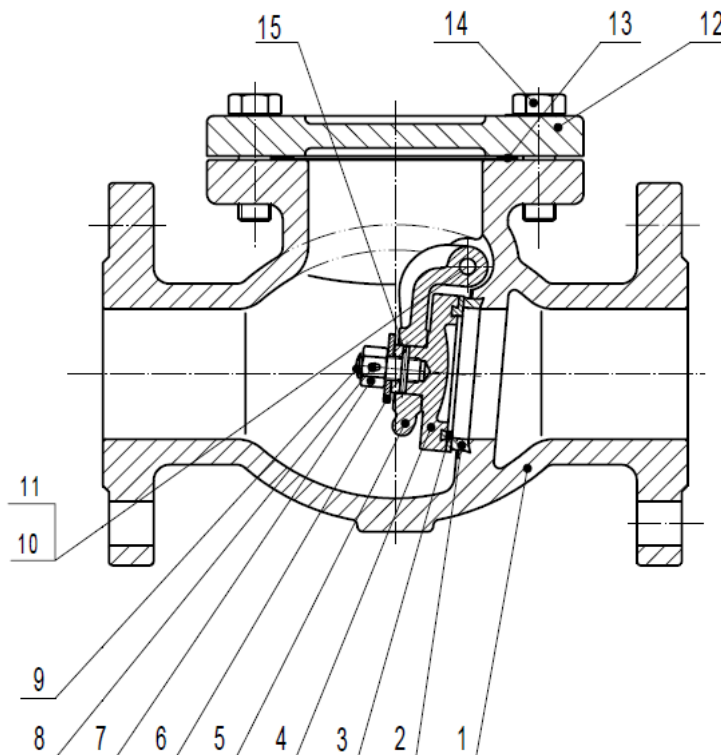
MATERIALS FOR METAL SEAT TYPE (REF.360) :

Item	Designation	Materials 360
1	Body	Cast iron EN GJL-250
2	Seat ring	Brass
3	Disc ring	Brass
4	Disc	Cast iron EN GJL-250
5	Hanger	Ductile iron EN GJS-400-15
6	Washer	Steel
7	Nut	Steel
8	Split Pin	AISI 304
9	Disc screw	Steel
10	Hexagon plug	Brass
11	Hanger pin	AISI 304
12	Bonnet	Cast iron EN GJL-250
13	Bonnet gasket	Graphite
14	Bonnet screw	Steel
15	Pin	AISI 304

CAST IRON SWING CHECK VALVE PN16

MATERIALS FOR EPDM SEAT TYPE (REF.362) :

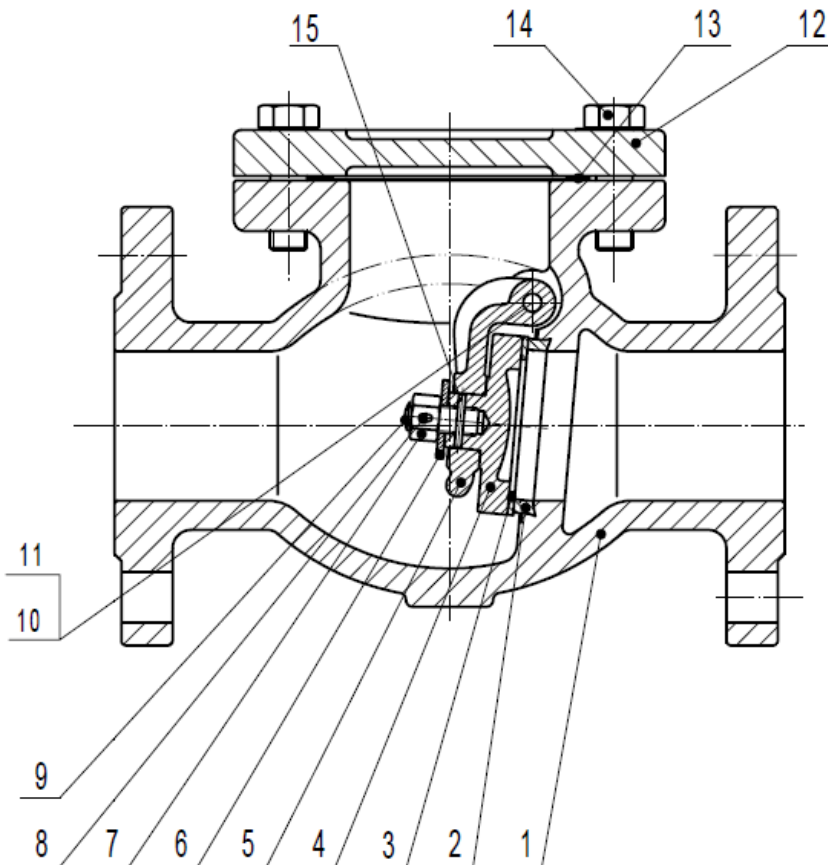

Item	Designation	Materials 362
1	Body	Cast iron EN GJL-250
2	Seat ring	Brass
3	Disc ring	EPDM
4	Disc	Cast iron EN GJL-250
5	Hanger	Ductile iron EN GJS-400-15
6	Washer	Steel
7	Nut	Steel
8	Split Pin	AISI 304
9	Disc screw	Steel
10	Hexagon plug	Brass
11	Hanger pin	AISI 304
12	Bonnet	Cast iron EN GJL-250
13	Bonnet gasket	Graphite
14	Bonnet screw	Steel
15	Pin	AISI 304

Sferaco 90 rue du Ruisseau 38297 St Quentin Fallavier Tel: + 33 (0) 474.94.15.90 Fax: + 33 (0) 474.95.62.08 Internet: www.sferaco.fr E-mail : sferaco@sferaco.fr

Date : 11/18

Page 4 sur 7

Rev.04

CAST IRON SWING CHECK VALVE PN16

CHECK VALVE SIZE (in mm) :

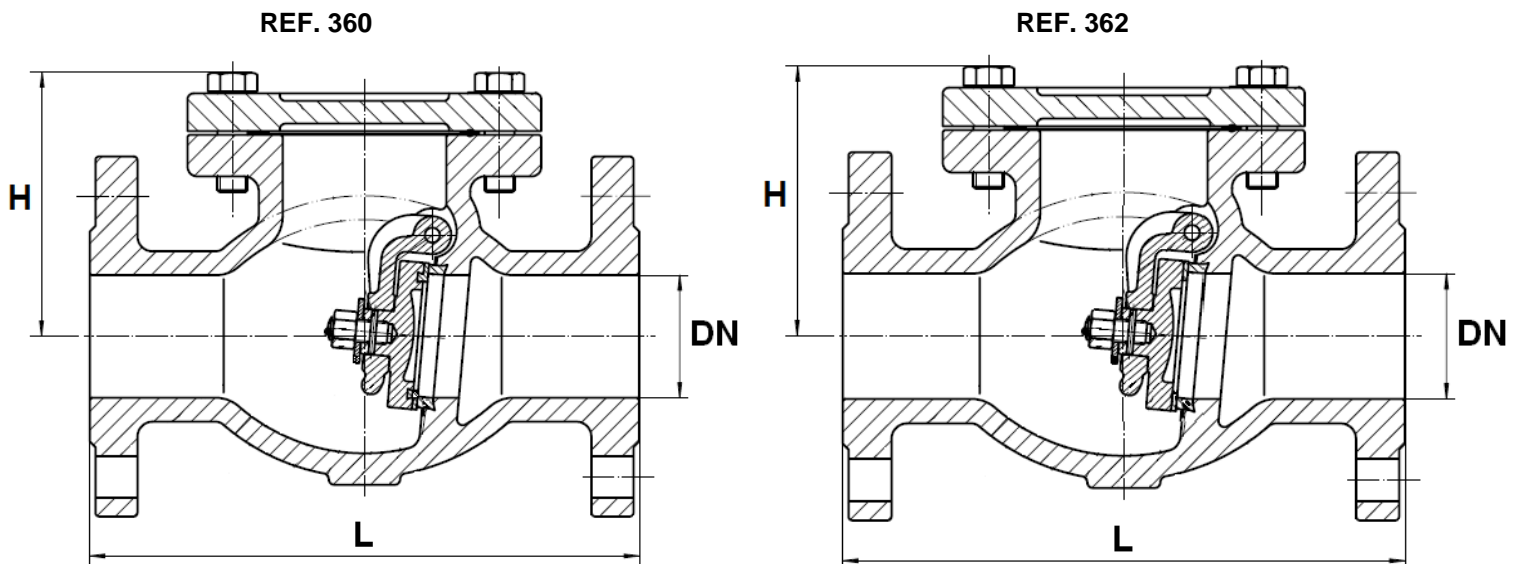

Ref.	DN	40	50	65	80	100	125	150	200	250	300
360 / 362	L	180	200	240	260	300	350	400	500	600	700
	H	109	112	132	141	162	192	211	270	316	357
	Weight (Kg)	8.5	11.2	15.5	19	28.5	42.2	57	93	159	215

FLANGES SIZE (in mm) :

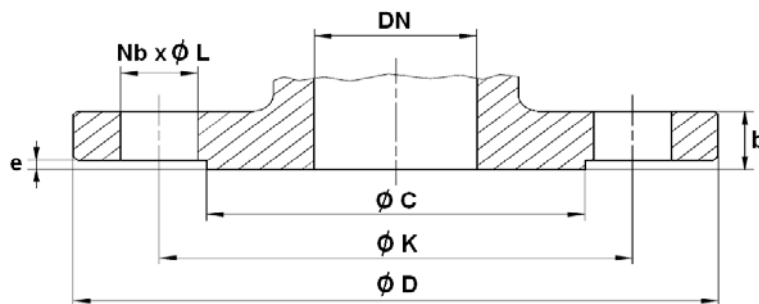

DN	40	50	65	80	100	125	150	200	250	300
Ø C	84	99	118	132	156	184	211	266	319	370
Ø D	150	165	185	200	220	250	285	340	405	460
Ø K	110	125	145	160	180	210	240	295	355	410
Nb x Ø L	4 x 19	4 x 19	4 x 19	8 x 19	8 x 19	8 x 19	8 x 23	12 x 23	12 x 28	12 x 28
b	18	20	20	22	24	26	26	30	32	32
e	3	3	3	3	3	3	3	3	3	4

CAST IRON SWING CHECK VALVE PN16

STANDARDS :

- Fabrication according to ISO 9001: 2015
- DIRECTIVE 2014/68/EU : CE N° 0038
Risk category III Module H
- Design according to DIN EN 12334
- Certificate 3.1 on request
- Pressure tests according to EN 12266-1 :
 - Rate A for Ref.362 with EPDM seat
 - Rate C for Ref.360 with brass seat
- Length according to EN 558 series 48 (DIN 3202 F6)
- PN16 R.F. flanges according to EN 1092-2

INSTALLATION POSITIONS :

Vertical position (ascendant fluid)

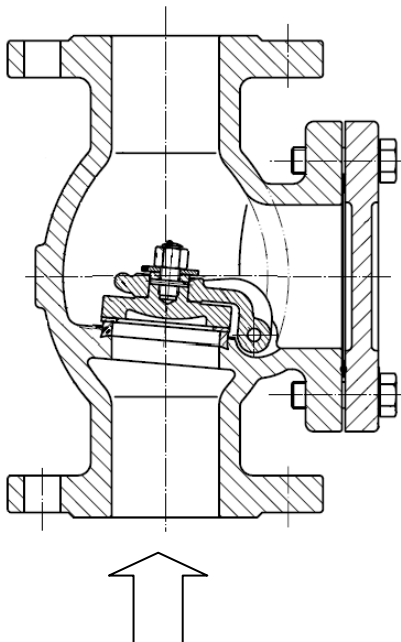

Horizontal position

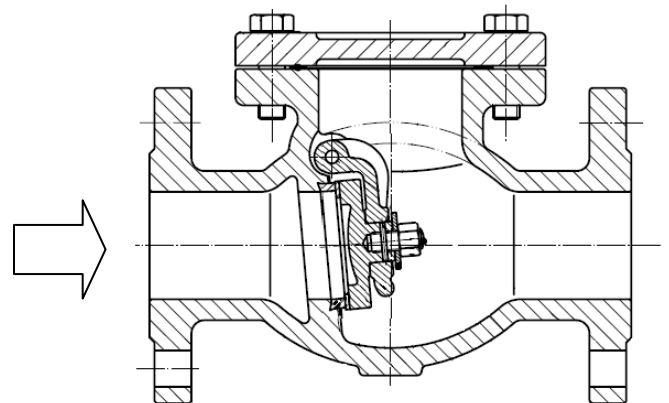

ADVICE : Our opinion and our advice are not guaranteed and SFERACO shall not be liable for the consequences of damages.
The customer must check the right choice of the products with the real service conditions.

Sferaco 90 rue du Ruisseau 38297 St Quentin Fallavier Tel: + 33 (0) 474.94.15.90 Fax: + 33 (0) 474.95.62.08 Internet: www.sferaco.fr E-mail : sferaco@sferaco.fr

Date : 11/18

Page 6 sur 7

Rev.04

CAST IRON SWING CHECK VALVE PN16

INSTALLATION INSTRUCTIONS

GENERAL GUIDELINES :

- Ensure that the check valves to be used are appropriate for the conditions of the installation (type of fluid, pressure and temperature).
- Be sure to have enough valves to be able to isolate the sections of piping as well as the appropriate equipment for maintenance and repair.
- Ensure that the valves to be installed are of correct strength to be able to support the capacity of their usage.

INSTALLATION INSTRUCTIONS :

- **Before installing the check valves, clean and remove any objects from the pipes** (in particular bits of sealing and metal) which could obstruct and block the valves.
- **Ensure that both connecting pipes either side of the check valve (upstream and downstream) are aligned (if they're not, the valves may not work correctly).**
- **Make sure that the two sections of the pipe (upstream and downstream) match, the check valve unit will not absorb any gaps. Any distortions in the pipes may affect the tightness of the connection, the working of the check valve and can even cause a rupture.** To be sure, place the kit in position to ensure the assembling will work.
- **If sections of piping do not have their final support in place, they should be temporarily fixed. This is to avoid unnecessary strain on the check valve.**
- If there is a direction changing or if there's another material, it's better to take away the check valve so that it is outside the turbulence area (**between 3 and 5 times the ND before and after**).
- After a pump please refer to **FD CEN/TR 13932** to install the check valve :
 - If it is essential to keep priming the pump, a non-return check valve can be fitted to the suction pipe at a distance **L1 (straight length suction) > 10xD1 (diameter suction)**
The check valve is designed to meet the maximum flow rate in service
 - In other cases, the non-return check valve is mounted on the discharge pipe at a distance of **L2 (straight length at discharge) > 3xD2 (diameter at discharge)**