

Full lift safety valve with spring loading. (AIT)

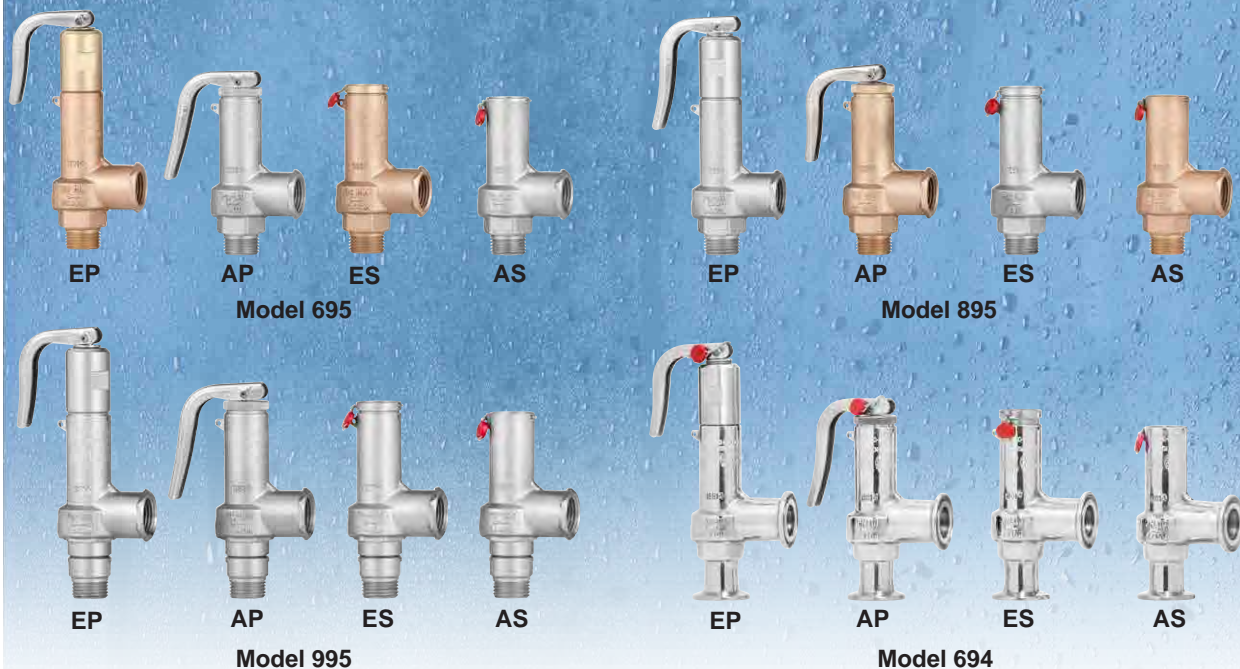

EN

Model 695 Model 895 Model 995 Model 694



The valve works as an automatic pressure releasing regulator activated by the static pressure existing at the entrance to the valve and is characterized by its ability to open instantly and totally.

Design in accordance with "International Standard ISO 4126-1 Safety Valves".

In accordance with the requirements of the pressure equipment directive 2014/68/EU.

EC valve verification certified by: TÜV Internacional Grupo TÜV Rheinland, S.L. EC 0035.

Type (Module D) EC examination report nº 33530455 certified by: TÜV Internacional Grupo TÜV Rheinland, S.L.

In compliance with the ATEX 2014/34/EU directive "Protective equipment and systems for use in potentially explosive atmospheres".

Other authorisations: IS CIR, ITI, NASTHOL, EAC, ...etc.

Specifications

- 90° angular flow.
- Activated by direct action helicoid spring.
- Simplicity of construction ensuring minimum maintenance.
- Materials carefully selected for their resistance to corrosion.
- Internal body designed to offer favourable flow profile.
- Sealing surfaces balanced and making them extremely tightness, even exceeding EN 12266-1 requirements.
- Great discharge capacity. For liquids typically used with openings similar to proportional safety valves.
- Auto-centering plug.
- Totally precise open and close.
- All the valves are supplied sealed at the set pressure requested, simulating operational conditions, and are vigorously tested.
- All components are numbered, registered and checked. If requested in advance, material, casting, test and efficiency certificates will be enclosed with the valve, and the instruction manual, in accordance with P.E.D. 2014/68/EU.

IMPORTANT

1.- Fluorelastomer (Vitón) seals, Silicone's rubber, PTFE (Teflón) o Perfluorelastomer (FFKM).

Achieving leakage levels less than: $0,3 \times 10^{-3} \frac{\text{Pa cm}^3}{\text{seg.}}$

FLUID		RANGE OF APPLICATION FOR THE SEALS							
		SET PRESSURE IN bar							
		0,20	1,80	4,80	20,00	30,00	36,01	45,00	144,00
Saturated steam		S		V		K		T	
Liquids and gases		S			V		K		T
SEALS		MINIMUM				MAXIMUM			
		TEMPERATURE IN °C							
Silicone's rubber	S	-50				200			
Fluorelastomer (Vitón)	V	-20				220			
PTFE (Teflón)	T	-196				260			
Perfluorelastomer (FFKM)	K	-10				250			

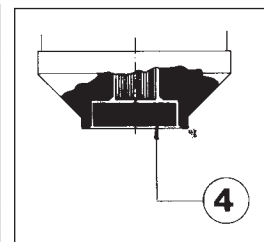

Depending on demand:

1. Buna-nitrils seals, Butyl, Natural rubber, E.P.D.M., Chlorosulphonate polyethylene (Hypalon), Neoprene, etc.
2. Possibility of manufacture in other types of material, for use in special working conditions (high temperatures, fluids, etc.).

N.º PIECE	PIECE	MATERIAL	
		BRONZE	STAINLESS STEEL
1	Body	Bronze (EN-CC491K)	S. steel (EN-1.4408)
2	Plug	Brass (EN-CW617N)	S. steel (EN-1.4401)
3	Shaft	S. steel (EN-1.4305)	S. steel (EN-1.4305)
4	Seal	Silicone's rubber	Silicone's rubber
		Fluorelastomer (Viton)	Fluorelastomer (Viton)
		PTFE (Teflon)	PTFE (Teflon)
		Perfluorelastomer (FFKM)	Perfluorelastómero (FFKM)
5	Limiter ring	S. steel (EN-1.4310)	S. steel (EN-1.4310)
6	End-stop	PTFE (Teflon)	PTFE (Teflon)
7	Spring press	Brass (EN-CW617N)	S. steel (EN-1.4305)
8	Spring	S. steel (EN-1.4310)	S. steel (EN-1.4310)
9	Clip	S. steel (EN-1.4310)	S. steel (EN-1.4310)
10	Lever	S. steel (EN-1.4301)	S. steel (EN-1.4301)
11	Sealing wire	Sealing wire	Sealing wire
12	Characteristic plate	Aluminium	Aluminium
13	Seal	Plastic	Plastic
14	Cap	Brass (EN-CW617N)	S. steel (EN-1.4305)
15	Hood coupling	PTFE (Teflón)	PTFE (Teflón)
16	Piston	Latón (EN-CW617N)	S. steel (EN-1.4305)
17	Piston Spring	S. steel (EN-1.4310)	S. steel (EN-1.4310)
18	Inlet clamp	-	S. steel (EN-1.4404)
19	Outlet clamp	-	S. steel (EN-1.4404)
20	O-ring	Fluorelastomer (Viton) (1)	Fluorelastomer (Viton) (1)
21	Seat	-	S. steel (EN-1.4401)
22	Screw cap	S. steel (EN-1.4305)	S. steel (EN-1.4305)

MODEL		R ₁ xR ₂	3/8"x1/2" a 1"x1"	
			PMS 36 bar	
695	OPERATING CONDITIONS	PN		40
		PRESSURE IN bar	36	36
		MAX. TEMPERATURE IN °C	200	250
		MIN. TEMPERATURE IN °C	-60	-60
895	OPERATING CONDITIONS	PN		40
		PRESSURE IN bar	36	36
		MAX. TEMPERATURE IN °C	200	250
		MIN. TEMPERATURE IN °C	-196	-196
995	OPERATING CONDITIONS	PN		160
		PRESSURE IN bar	-	144
		MAX. TEMPERATURE IN °C	-	250
		MIN. TEMPERATURE IN °C	-	-60
694	OPERATING CONDITIONS	DN ₁ xDN ₂	10x15 a 25x25	
		PN	-	16
		PRESSURE IN bar	-	16
		MAX. TEMPERATURE IN °C	-	250
		MIN. TEMPERATURE IN °C	-	-60

(1) Mod. 895; Perfluorelastomer (FFKM)

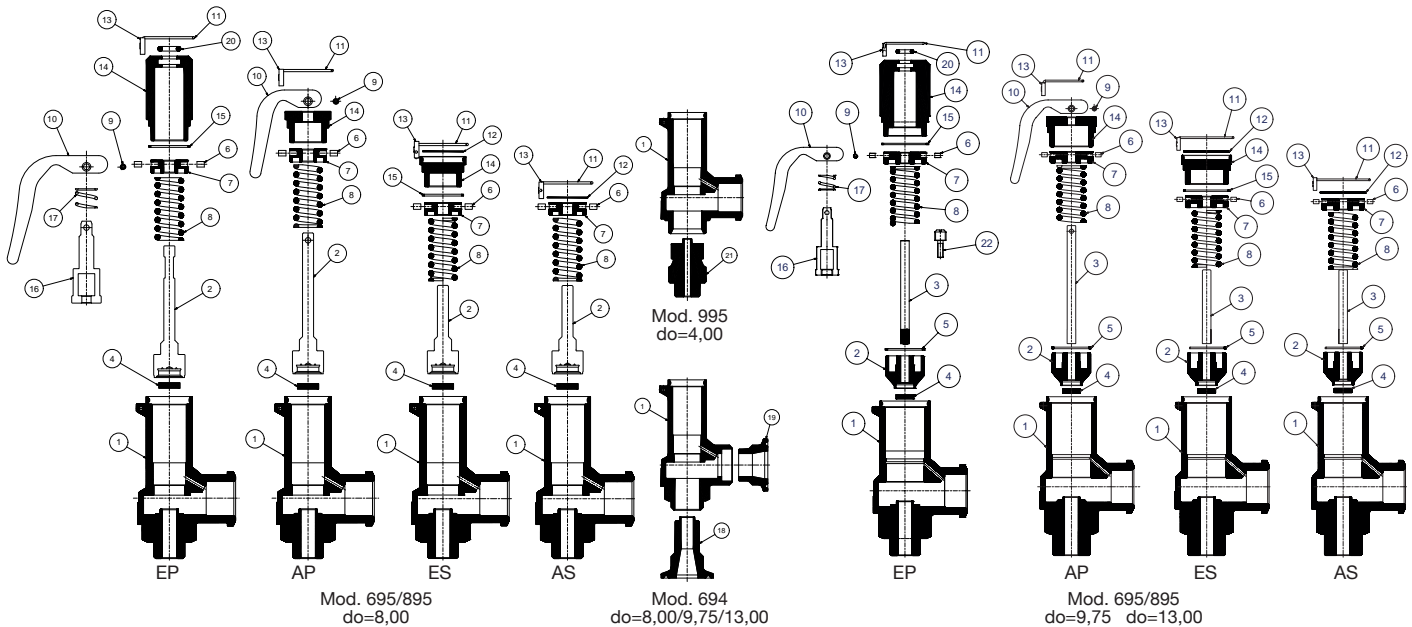

Full lift safety valve with spring loading (AIT) version EP.

1. Disassembly and assembly

1.1 Disassembly

To replace the spring (8) or clean any of the internal components of the valve, proceed in the following manner:

- A - Cut the seal thread (11) with pliers.
- B - Withdraw the fastener (9), using a punching tool, until the lever (10) comes free.
- C - Unscrew and extract the hood (14).
- D - Unscrew the piston (16) from the rod (3) and then the screw cap (22).
- E - Holding the rod (3), unscrew the spring press (7) until you note a releasing of the spring (8).
- F - Extract the spring (8).

1.2 Assembly

- A - Enter the spring (8) through the upper part of the rod (3).
- B - Screw the spring press (7) holding the rod (3) and the screw cap (22).
- C - Adjust the set pressure with the spring press (7).
- D - Screw the piston (16) to the rod (3).
- E - Screw the hood (14).
- F - Place the lever (10) and fix it with the fastener (9).

2. Adjusting the firing pressure

- A - Proceed according to points 1.1.A, 1.1.B, 1.1.C, 1.1.D, 1.1.E.
- B - Proceed according to points 1.2.C, 1.2.D, 1.1.E, 1.1.F.

Full lift safety valve with spring loading (AIT) version AP.

1. Disassembly and assembly

1.1 Disassembly

To replace the spring (8) or clean any of the internal components of the valve, proceed in the following manner:

- A - Cut the seal thread (11) with pliers.
- B - Withdraw the clip (9), using a punching tool, until the lever (10) comes free.
- C - Unscrew and extract the hood (14).
- D - Holding the rod (3), unscrew the spring press (7) until you note a releasing of the spring (8).
- E - Extract the spring (8).

1.2 Assembly

- A - Enter the spring (8) through the upper part of the rod (3).
- B - Screw the spring press (7) holding the rod (3).
- C - Adjust the set pressure with the spring press (7).
- D - Screw the hood (14).
- E - Place the lever (10) and fix it with the fastener (9).

2. Adjusting the firing pressure

- A - Proceed according to points 1.1.A, 1.1.B, 1.1.C, 1.1.D.
- B - Proceed according to points 1.2.C, 1.2.D, 1.1.E.

Full lift safety valve with spring loading (AIT) version ES.

1. Disassembly and assembly

1.1 Disassembly

To replace the spring (8) or clean any of the internal components of the valve, proceed in the following manner:

- A - Cut the seal thread (11) with pliers and extract the characteristic plate (12).
- B - Unscrew and extract the hood (14).
- C - Holding the rod (3), unscrew the spring press (7) until you note a releasing of the spring (8).
- D - Extract the spring (8).

1.2 Assembly

- A - Enter the spring (8) through the upper part of the rod (3).
- B - Screw the spring press (7) holding the rod (3).
- C - Adjust the set pressure with the spring press (7).
- D - Screw the hood (14).

2. Adjusting the firing pressure

- A - Proceed according to points 1.1.A, 1.1.B, 1.1.C.
- B - Proceed according to points 1.2.C, 1.2.D..

Full lift safety valve with spring loading (AIT) version AS.

1. Disassembly and assembly

1.1 Disassembly

To replace the spring (8) or clean any of the internal components of the valve, proceed in the following manner:

- A - Cut the seal thread (11) with pliers and extract the characteristic plate (12).
- B - Holding the rod (3), unscrew the spring press (7) until you note a releasing of the spring (8).
- C - Extract the spring (8).

1.2 Assembly

- A - Enter the spring (8) through the upper part of the rod (3).
- B - Screw the spring press (7) holding the rod (3).
- C - Adjust the set pressure with the spring press (7).

2. Adjusting the firing pressure

- A - Proceed according to points 1.1.A, 1.1.B.
- B - Proceed according to points 1.2.C.

MODEL 695/895/995												
R ₁ xR ₂		3/8"x1/2"				1/2"x 1/2"				1/2"x 3/4"		
CONNECTIONS		Male thread x Female thread Whitworth gas-tight cylindrical ISO 228/1										
MODEL 694												
DN ₁ xDN ₂		10x15				15x15				15x20		
CONNECTIONS		CLAMP ISO 2852:1993										
d ₀	694/695/895	8,00				9,75						
	995	4,00										
$A_0 = \frac{\pi \cdot d_0^2}{4}$	694/695/895	50,26				74,66						
	995	12,57										
H	695/895	-	88	-	-	-	91	-	-	-	109	
	995	-	99	-	-	-	102	-	-	-		
	694	-	101	-	-	-	101	-	-	-	121	
H ¹	695/895	102	-	136	93	105	-	139	96	127	-	
	995	113	-	147	-	116	-	150	107	-	-	
	694	115	-	149	106	115	-	149	106	139	-	
h ¹	695/895	119	-	148	109	122	-	151	112	142	-	
	995	130	-	159	120	133	-	162	123	-	-	
	694	132	-	161	122	132	-	161	122	154	-	
A	695/895/995	9				12				12		
	694	22				24						
L ₁	695/895/995	36				44						
	694	41,50				52						
L ₂	695/895	32,50				35,50				45,50		
	995	43,50				46,50						
	694	45,50				57,50						
INTAKE FLANGE	PN-16 CLAMP ISO 2852:1993	C ₆₁	14				18,10				18,10	
		C ₇₁	34				34				34	
		C ₂₁	27,50				27,50				27,50	
		L ₁₁	2,85				2,85				2,85	
ESCAPE FLANGE	PN-16 CLAMP ISO 2852:1993	C ₆₂	18,10				23,70				23,70	
		C ₇₂	34				50,50				50,50	
		C ₂₂	27,50				43,50				43,50	
		L ₁₂	2,85				2,85				2,85	
WEIGHT IN Kgs.		EP	AP	ES	AS	EP	AP	ES	AS	EP	AP	
695/895/995	BRONZE	0,47	0,38	0,36	0,34	0,47	0,38	0,36	0,34	0,97	0,74	
	S. STEEL	0,45	0,36	0,34	0,32	0,45	0,36	0,34	0,32	0,95	0,72	
694	S. STEEL	0,50	0,41	0,39	0,37	0,50	0,41	0,39	0,37	1,06	0,83	
CODE	695	BRONZE 2002-695.	83810	838110	838120	838130	80210	802110	802120	802130	80211	802111
		S. STEEL 2002-695.	83820	838210	838220	838230	80220	802210	802220	802230	80221	802211
	895	BRONZE 2002-895.	83810	838110	838120	838130	80210	802110	802120	802130	80211	802111
		S. STEEL 2002-895.	83820	838210	838220	838230	80220	802210	802220	802230	80221	802211
	995	S. STEEL 2002-995.	03820	03821	03822	03823	0022	00221	00222	00223		
		S. STEEL 2002-694.	83820	838210	838220	838230	80220	802210	802220	802230	80221	802211

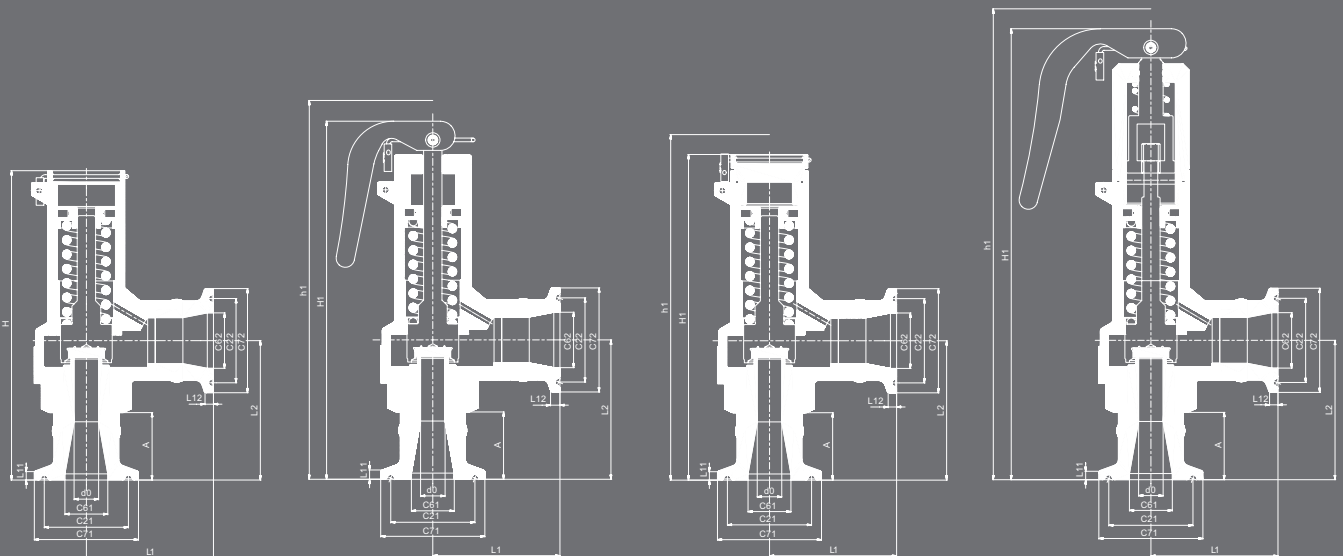

MODEL 695/895/995													
1/2"x 3/4"		3/4"x3/4"				3/4"x1"				1"x1"			
Male thread x Female thread Whitworth gas-tight cylindrical ISO 228/1													
MODEL 694													
15x20		20x20				20x25				25x25			
CLAMP ISO 2852:1993													
9,75						13,00							
74,66						132,73							
-	-	-	112	-	-	-	138	-	-	-	141	-	-
-	-	-	121	-	-	-	148	-	-	-	148	-	-
164	116	130	-	167	119	159	-	196	147	162	-	199	150
176	128	139	-	176	128	169	-	206	157	169	-	206	157
178	134	145	-	181	137	174	-	210	165	147	-	213	168
190	146	154	-	190	146	184	-	220	175	154	-	220	175
12		15				15				18			
		24								25			
		44								60			
		52								67			
45,50		48,50				58,50				61,50			
		57,50								68,5			
18,10		23,70				23,70				29,70			
34		50,50								50,50			
27,50		43,50								43,50			
		2,85								2,85			
		23,70								29,70			
		50,50								50,50			
		43,50								43,50			
		2,85								2,85			
ES	AS	EP	AP	ES	AS	EP	AP	ES	AS	EP	AP	ES	AS
0,72	0,70	0,97	0,74	0,72	0,70	1,67	1,35	1,33	1,31	1,67	1,35	1,33	1,31
0,70	0,68	0,95	0,72	0,70	0,68	1,65	1,33	1,31	1,29	1,65	1,33	1,31	1,29
0,81	0,79	1,10	0,87	0,85	0,83	1,74	1,52	1,50	1,48	1,02	1,80	1,78	1,76
802121	802131	83410	834110	834120	834130	83411	834111	834121	834131	81010	810110	810120	810130
802221	802231	83420	834210	834220	834230	83421	834211	834221	834231	81020	810210	810220	810230
802121	002131	83410	834110	834120	834130	83411	834111	834121	834131	81010	810110	810120	810130
802221	802231	83420	834210	834220	834230	83421	834211	834221	834231	81020	810210	810220	810230

802221	802231	83420	834210	834220	834230	83421	834211	834221	834231	81020	810210	810220	810230
--------	--------	-------	--------	--------	--------	-------	--------	--------	--------	-------	--------	--------	--------

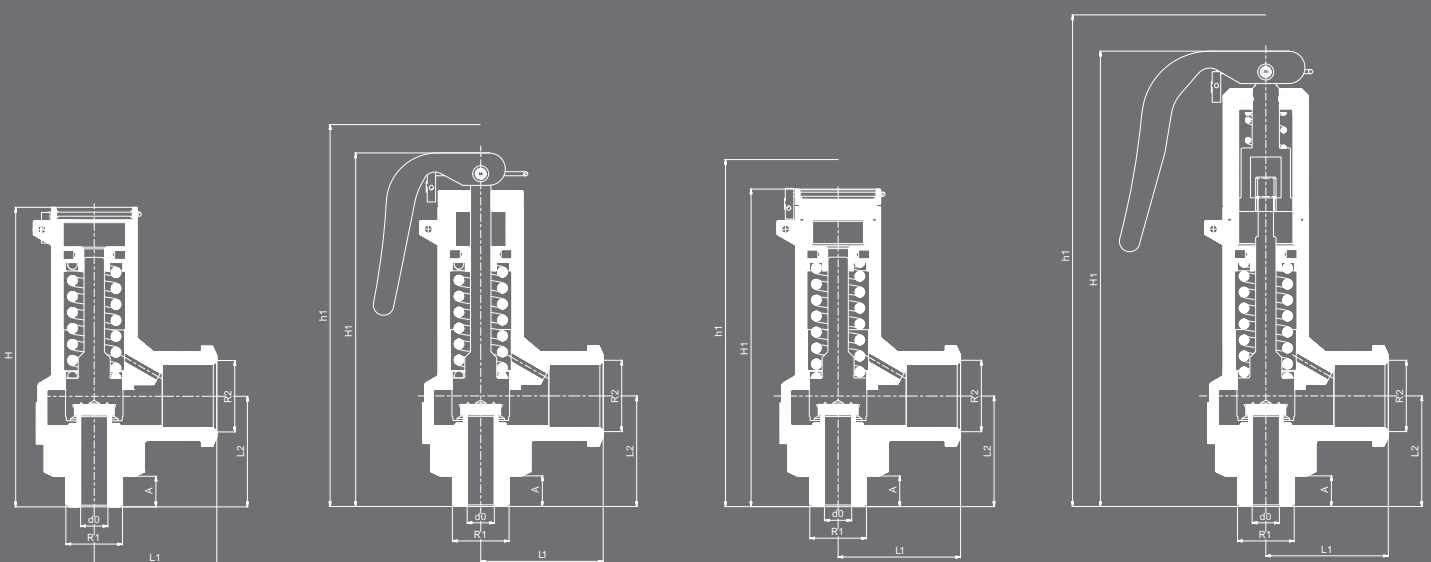

SET PRESSURES AND REGULATING RANGES									
MODEL			695/895/995/694						
ENTRY CONNECTION	695/895/995		R ₁	3/8"	1/2"	1/2"	3/4"	3/4"	1"
	694		DN ₁	10	15	15	20	20	25
EXIT CONNECTION	695/895/995		R ₂	1/2"		3/4"		1"	
	694		DN ₂	15		20		25	
d ₀	695/895/694			8,00		9,75		13,00	
	995			4,00					
SET PRESSURE IN bar	MAXIMUM	695/895	PMS. 36 bar	36		36		36	
		695	PN-40	36		36		36	
		995	PN-160	144					
		694	PN-16	16		16		16	
	MINIMUM	695/895	PMS. 36 bar	0,2		0,2		0,2	
		695	PN-40	0,2		0,2		0,2	
		995	PN-160	36,1					
		694	PN-16	0,2		0,2		0,2	
SPRING REGULATING RANGE IN bar	695/895/694	995							
	0,20 a 0,70		CODE	56160		56169		56178	
	0,60 a 1,60		CODE	56161		56170		56179	
	1,50 a 3,50		CODE	56162		56171		56180	
	3,40 a 5,50		CODE	56163		56172		56181	
	5,40 a 10,00	36,10 a 40,00	CODE	56164- 56334		56173		56182	
	9,80 a 15,00	39,00 a 60,00	CODE	56165- 56335		56174		56183	
	14,50 a 20,00	58,00 a 80,00	CODE	56166- 56336		56175		56184	
	19,00 a 25,00	76,00 a 100,00	CODE	56167- 56337		56176		56185	
	24,00 a 36,00	96,00 a 144,00	CODE	56168- 56338		56177		56186	

RECOMMENDED RANGES OF APPLICATION						
MODEL		695/895/995/694				
		AP	AS	EP	ES	
FLUID	SATURATED STEAM		*	*	*	*
	GASES	INERT	*	*	*	*
		NON INERT			*	*
LIQUIDS				*	*	
OPENING PRESSURE IN % OF THE SET PRESSURE			+10%			
CLOSURE PRESSURE IN % OF THE SET PRESSURE			-10%			

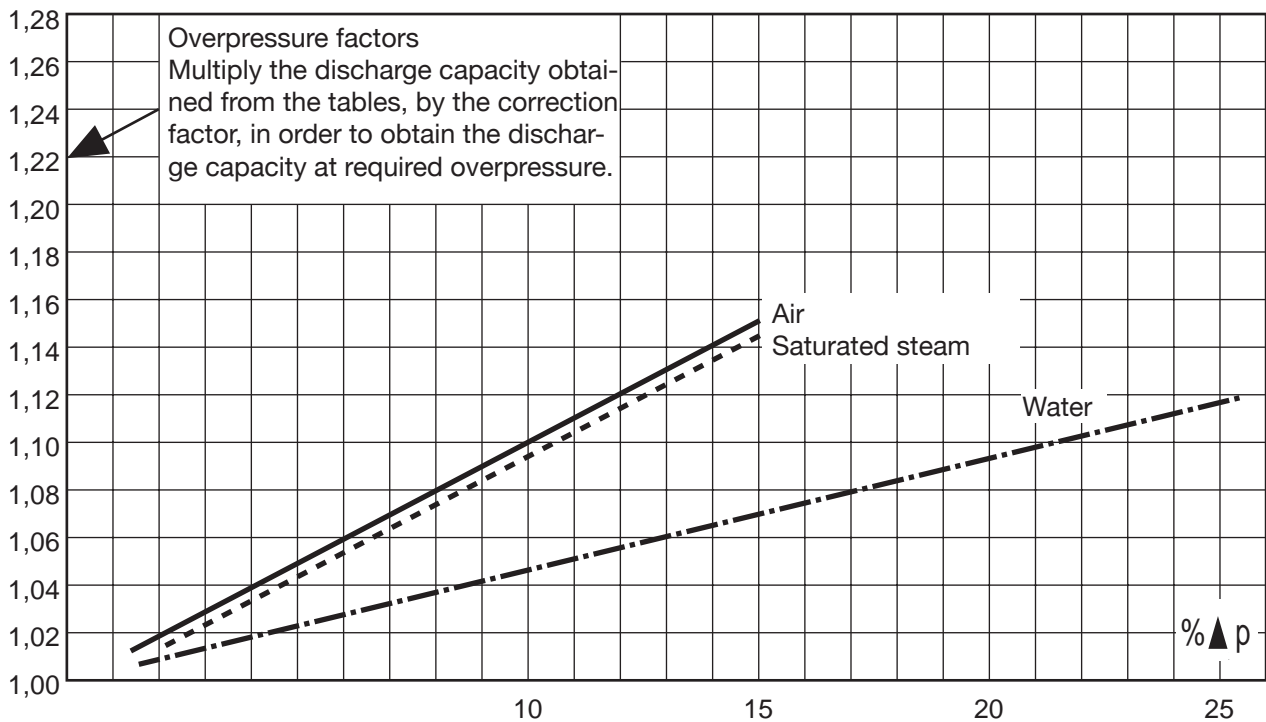
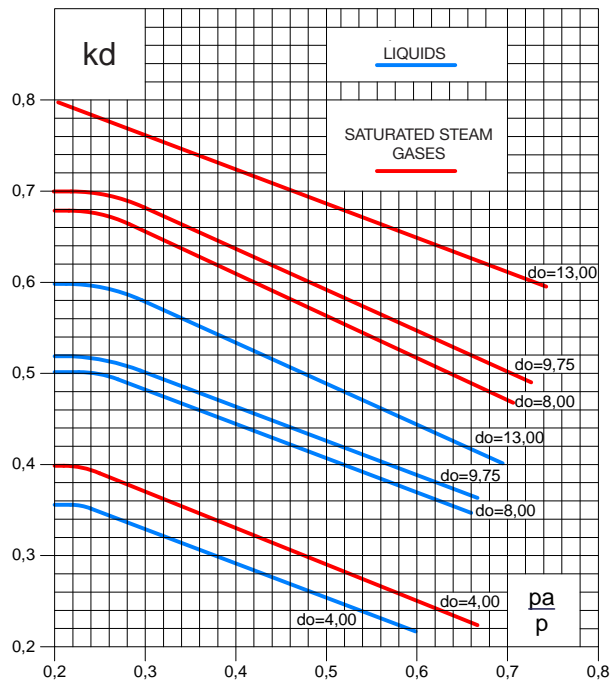

DISCHARGE CAPACITY													
MODEL	695-895									995			
ENTRY CONNECTION	R1	3/8"	1/2"	1/2"	3/4"	3/4"	1"	3/8"	1/2"				
EXIT CONNECTION	R2	1/2"		3/4"		1"			1/2"				
MODEL	694												
ENTRY CONNECTION	DN1	10	15	15	20	20	25						
EXIT CONNECTION	DN2	15		20		25							
do	8,00			9,75			13,00			4,00			
$A_0 = \frac{\pi \cdot d_0^2}{4}$	50,26			74,66			132,73			12,57			
<p>p [bar]</p> <p>SET PRESSURE IN bar</p>	<p>For other, not so dense liquids, other than water at 20°C apply:</p> $V_i = \sqrt{\frac{\rho A}{\rho L}} \cdot V_A \quad V_i = V_i \cdot \sqrt{\frac{\rho A}{\rho L}}$ <p>I- Saturated steam in kg/h. II- Air at 0°C and 1.013 bar in [Nm³/h]. III- Water at 20°C in l/h.</p> <p>V_i = Water flow according to table. V_i = Liquid flow. ρA = Water density at a 20° C. (ρA= 998 kg/m³) ρL = Liquid density.</p>												
		I	II	III	I	II	III	I	II	III	I	II	III
	0,5	30	34	924	45	51	1399	91	103	2870			
	1,0	39	47	1306	59	71	1979	120	144	4059			
	1,5	49	59	1600	73	88	2423	149	180	4971			
	2,0	58	70	1848	87	106	2798	178	215	5740			
	2,5	67	82	2066	101	124	3128	206	251	6417			
	3,0	77	94	2263	115	141	3427	235	287	7030			
	3,5	86	105	2444	129	159	3702	263	323	7593			
	4,0	95	117	2613	143	176	3957	291	359	8117			
	4,5	104	129	2771	157	194	4197	320	395	8610			
	5,0	113	140	2921	171	212	4424	348	431	9076			
	6,0	132	164	3200	198	247	4847	404	503	9942			
7,0	150	187	3457	226	282	5235	460	575	10738				
8,0	168	211	3695	253	318	5596	515	646	11480				
9,0	186	234	3919	281	353	5936	571	718	12176				
10,0	204	258	4131	308	388	6257	627	790	12835				
12,0	240	304	4526	362	459	6854	738	934	14060				
14,0	277	351	4888	417	529	7403	849	1077	15186				
16,0	313	398	5226	471	600	7915	960	1221	16235				
18,0	349	445	5543	526	670	8395	1070	1365	17220				
20,0	385	492	5843	580	741	8849	1182	1508	18151				
22,0	421	538	6128	635	812	9281	1293	1652	19037				
24,0	458	585	6400	690	882	9693	1404	1796	19884				
26,0	494	632	6662	745	953	10089	1516	1939	20696				
28,0	531	679	6913	800	1023	10470	1628	2083	21477				
30,0	567	726	7156	855	1094	10837	1740	2226	22231				
32,0	604	773	7391	910	1164	11193	1852	2370	22960				
34,0	641	819	7618	966	1235	11537	1965	2514	23666				
36,0	678	866	7839	1021	1306	11872	2079	2657	24352				
38,0										102	134	1363	
40,0										105	141	1382	
42,0										107	148	1400	
44,0										110	155	1418	
46,0										112	162	1435	
48,0										115	169	1453	
50,0										117	176	1470	
52,0										119	182	1487	
54,0										121	189	1504	
56,0										124	196	1520	
58,0										126	203	1537	
60,0										128	210	1553	
62,0										130	217	1569	
64,0										132	224	1585	
66,0										134	231	1601	
68,0										136	238	1616	
70,0										138	244	1632	
72,0										140	251	1647	
74,0										142	258	1662	
76,0										144	265	1677	
78,0										146	272	1692	
80,0										147	279	1707	
82,0										149	286	1722	
84,0										151	293	1736	
86,0										153	300	1751	
88,0										155	306	1765	
90,0										156	313	1779	
92,0										158	320	1793	
94,0										160	327	1807	
96,0										161	334	1821	
98,0										163	341	1835	
100,0										165	348	1848	
105,0										169	365	1902	
110,0										173	382	1954	
115,0										176	399	2005	
120,0										180	417	2054	
125,0										184	434	2103	
130,0										187	451	2150	
135,0										191	468	2196	
140,0										195	485	2242	
145,0										198	503	2286	

COEFFICIENT OF DISCHARGE									
MODEL									
		695/895/995/694							
ENTRY CONNECTION	R ₁	3/8"	1/2"	1/2"	3/4"	3/4"	1"		
	694	DN ₁	10	15	15	20	20	25	
EXIT CONNECTION	R ₂	1/2"		3/4"		1"			
	694	DN ₂	15	20	25				
d ₀	695/895/694		8,00	9,75	13,00				
	995		4,00						
h	695/895/694		2,50	4,00	5,50				
	995		0,31			0,41	0,42		
h/d ₀	695/895/694		0,68		0,69		0,79		
	995		0,40						
COEFFICIENT OF DISCHARGE c _d (1)	695/895/694		0,51		0,52		0,60		
	995		0,35						
(1) For set pressures less than 3 bar see graph of discharge coefficient.									
<p>pa = Backpressure permitted [bar] absolute. p = Set pressure [bar] absolute. kd = Coefficient of discharge.</p>									

Calculus according to ISO 4126-1 "Safety valves".