

### FIG 500T COMBINED PRESSURE & TEMPERATURE RELIEF VALVE

#### FEATURES & BENEFITS

The NABIC Fig 500T provides protection against excess temperature as well as pressure protection. It automatically discharges hot water to prevent a predetermined set pressure and/or temperature being exceeded. Each of the lift mechanisms is independent of each other. Designed and tested to BS EN 4126, BS 6283 (when 50% of BS EN ISO 4126 -1 ratings at 1 bar or temperature ratings are used). WRAS approved (1 bar and above). Valve is suitable for PED2014/68/EU cat 1 use only.

- Size Range: DN15 - DN50
- Resilient Viton soft seat design
- Powerful thermostat
- Pressure setting locked and sealed
- Drain plug fitted on DN32 and above

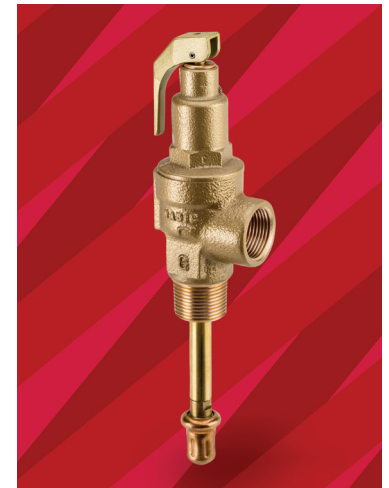

#### PRESSURE RATINGS & TEMPERATURE RANGE

MIN - MAX SET PRESSURE (bar)	MIN - MAX TEMPERATURE (°C)
0.4 to 12.5	-20 to 95

#### DIMENSIONS & WEIGHTS

SIZE DN	R BSPT Inlet	Rp BSP Outlet	A (mm)	B (mm)	C (mm)	D (mm)	WEIGHTS (kg)
15	3/4"	3/4"	33	81	48	229	0.72
20	1"	1"	39	81	47	238	1.00
25	1 1/4"	1 1/4"	45	88	56	269	1.54
32	1 1/2"	1 1/2"	54	127	62	354	3.00
40	2"	2"	64	127	71	398	4.50
50	2 1/2"	2 1/2"	76	127	82	429	7.78

#### PART NAME & MATERIALS

ITEM NO.	PART NAME	MATERIAL
1	Thrust Washer	Brass, BS EN 12164 CW609N
2	Grubscrew	Steel
3	Test Lever	Brass, BS EN 1982 CC754S
4	Spring	Chrome Vanadium Alloy Steel, BS 2803 735 A50 HS (Stainless Steel, BS 2056 302S26 Opt)
5	Label	Yellow kapton
6	Spring Cover	Bronze, BS EN 1982 CC491K
7	Piston	Brass, BS EN 12164 CW609N
8	Diaphragm	Silicon Rubber
9	Seat Seal Holder	Bronze, BS EN 1982 CC491K / Brass BS EN 12164 CW602N (DZR)
10	Seat Seal	PTFE (Viton Opt)
11	Starlock Washer	Stainless Steel
12	Body	Bronze, BS EN 1982 CC491K
13	Lever Pin	Steel
14	Lead Seal	Lead
15	Adjusting Screw	Brass, BS EN 12164 CW609N
16	Spring Plate	Brass, BS EN 12164 CW609N
17	Spindle	Brass, BS EN 12164 CW721R
18	Seat Seal Retaining Plate	Bronze, BS EN 1982 CC491K / Brass BS EN 12164 CW602N (DZR)
20	Push Rod	Stainless Steel, BS 970 316 S31
21	Adaptor	Brass, BS EN 12164 CW602N (DZR)
22	Thermostat	Copper/Brass BS EN 12164 CW602N (DZR)

#### MEDIUM

Hot water only.

#### PIPE CONNECTIONS

Threaded male inlet connection R (BSPT) to BS EN 10226-2. Threaded female outlet connections Rp (BSP) to BS EN 10226-1.

#### PRODUCT TESTING

All valves are shell and seat tested (to confirm set pressure) before leaving the factory and all valves are supplied pre-set with a tamper proof seal. Pressure Test Certificate and Letters of Conformity available on request.

#### DIMENSIONAL DRAWING

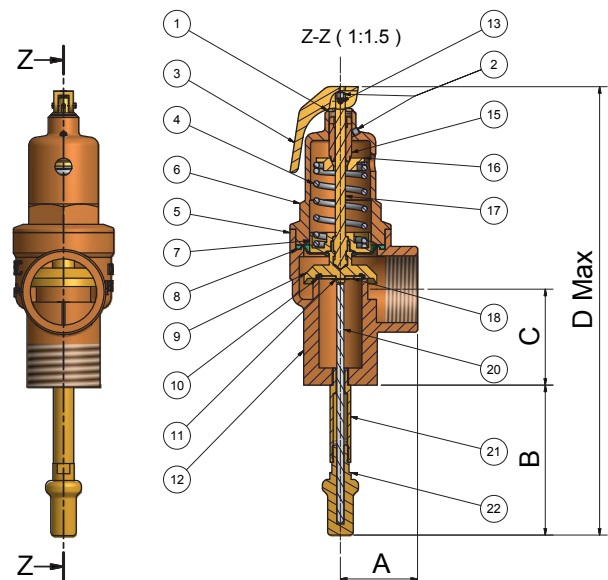

# FIG 500T COMBINED PRESSURE & TEMPERATURE RELIEF VALVE

### TEMPERATURE RATING

The discharge capacity of the safety valve must be equal to or greater than the output of the boiler or system it is protecting. Two methods of sizing are employed for combined pressure and temperature relief valves; one, based on the pressure element of the valve, the other based on the temperature element. To ensure that the correct method is used, reference should be made to the relevant BS specification to the design of the boiler or system. If in doubt, choose the method which produces the lower rating.

SIZE	DN15	DN20	DN25	DN32	DN40	DN50
kW	25	45	65	105	165	255

To convert to Btu/hr multiply by 3400.

The above discharge capabilities represent approximately 45% of the relief capability of the valve, when steam at the pressure of 1 bar causes the thermostat to open the valve.

### DISCHARGE CAPABILITIES

Fig 500T capacities are tabulated below to assist selection.

HOT WATER - UNVENTED SYSTEM - 10% OVERPRESSURE (BS 6759)						
SET PRESSURE BAR	kW					
	DN15	DN20	DN25	DN32	DN40	DN50
1.0	46	81	127	208	326	509
2.0	70	124	194	317	496	775
3.0	94	167	260	427	667	1041
4.0	118	209	327	536	837	1308
6.0	166	294	460	754	1179	1841
8.0	214	380	594	972	1520	2373
10.0	262	465	727	1190	1861	2906
12.5	322	571	894	1463	2287	3572

To convert to Btu/hr multiply by 3400.

The above discharge capabilities have been calculated in accordance with BS 6759:Part 1, using a derated coefficient of discharge (Kdr) of 0.479.

They represent the steam relief capability of the pressure element of the valve at 10% overpressure.

### APPROVALS



ISO 14001 Reg No. EMS 78657



FM00311 ISO 9001



# NABIC®

46-48 WILBURY WAY, HITCHIN, HERTFORDSHIRE, SG4 0UD

Tel: +44 (0) 1462 443 278 Fax: +44 (0) 1462 443 127

E-mail: [nabicsales@cranebsu.com](mailto:nabicsales@cranebsu.com) Web: [www.nabicvalves.com](http://www.nabicvalves.com)

Every effort has been made to ensure that the information contained in this publication is accurate at the time of publishing. NABIC assumes no responsibility or liability for typographical errors or omissions or for any misinterpretation of the information within the publication and reserves the right to change without notice.

N\_Fig.500T  
0819

## OUR GENIUS IS VALVES



BUILDING SERVICES & UTILITIES

[www.cranebsu.com](http://www.cranebsu.com)



View online, on mobile and on tablet  
[www.nabicvalves.com](http://www.nabicvalves.com)