

**Description:**

The HP Series Pneumatic Actuator body is manufactured from extruded Aluminium alloy and is hard anodized to protect both internal & external surfaces against corrosion.

The End Caps are Diecast Aluminium and are coated with Polyester.

The Pinion shaft is Nickel Plated Alloy steel and the Pistons are Diecast Aluminium.

Self Lubricating (Polypropylene + GF) Piston Guides provide travel stability & NBR seals are suitable for standard temperature range. (Viton seals are available for higher or lower temperature ranges)

All actuators have travel stops for both the open and closed position.

Springs are pre-loaded to ensure safety when removing end caps. Double Acting Actuators can easily be converted to spring return and vice versa.

All actuators are designed to the latest ISO/Namur standards and are ATEX approved.

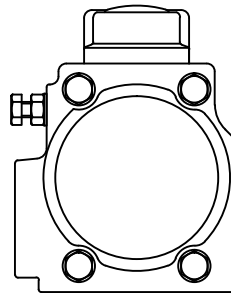
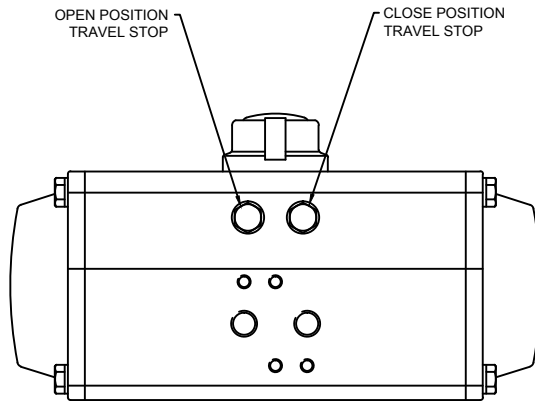

**Specification:**

- Working Pressure : Double Acting : 2.5 to 8 bar  
Single Acting : 2.5 to 8 bar
- Air supply : Air or non-corrosive gas (ie. Nitrogen)
- Working Temperatures : From -20° to +80°C (-35° to +80°C & -20° to +150°C Options available)
- Lubrication : Lubricated for normal working life
- Rotation : Anti-clockwise opening  
To reverse actuator rotation, invert pistons
- Movement : Rotation 90° (Adjustable ±5° each end of stroke)
- Certification Available : SIL2, ATEX, PED, CE, RINA (Marine)

| ACTUATOR | AIR VOLUME/STROKE (LITRES) |               | OPERATING TIME AT 6 BAR (SECS) |               |         | WEIGHT (KG)   |               |
|----------|----------------------------|---------------|--------------------------------|---------------|---------|---------------|---------------|
|          | SPRING RETURN              | DOUBLE ACTING | DOUBLE ACTING                  | SPRING RETURN |         | DOUBLE ACTING | SPRING RETURN |
|          |                            |               |                                | OPENING       | CLOSING |               |               |
| HP-50    | 0.1                        | 0.3           | <1                             | <1            | <1      | 1.1           | 1.4           |
| HP-63    | 0.2                        | 0.5           | <1                             | <1            | <1      | 1.8           | 2             |
| HP-66    | 0.2                        | 0.5           | <1                             | 1             | <1      | 2.3           | 2.6           |
| HP-75    | 0.3                        | 0.8           | <1                             | 1             | 1       | 3             | 3.5           |
| HP-88    | 0.5                        | 1.3           | <1                             | 1             | 1       | 4.6           | 5.3           |
| HP-100   | 0.7                        | 1.8           | <1                             | 1             | 1       | 5.8           | 6.8           |
| HP-115   | 1.2                        | 3.0           | 1                              | 1.5           | 1.5     | 8.9           | 10.3          |
| HP-125   | 1.5                        | 3.8           | 1                              | 3             | 2       | 11.3          | 13.2          |
| HP-145   | 2.4                        | 6.2           | 2                              | 3             | 2       | 16.7          | 20            |
| HP-160   | 3.1                        | 7.3           | 2                              | 3             | 2       | 22            | 26.5          |
| HP-180   | 4.3                        | 11.2          | 2                              | 3             | 2       | 28            | 35            |
| HP-200   | 5.9                        | 15.4          | 2                              | 4             | 3       | 39            | 48            |
| HP-211   | 5.1                        | 19.1          | 4                              | 5             | 3       | 46            | 65            |
| HP-212   | 9.6                        | 29.6          | 5                              | 6             | 3       | 71            | 95            |



DATA SHEET No.  
1.01.3

ISSUE DATE  
SEPT 2015